

SLS型

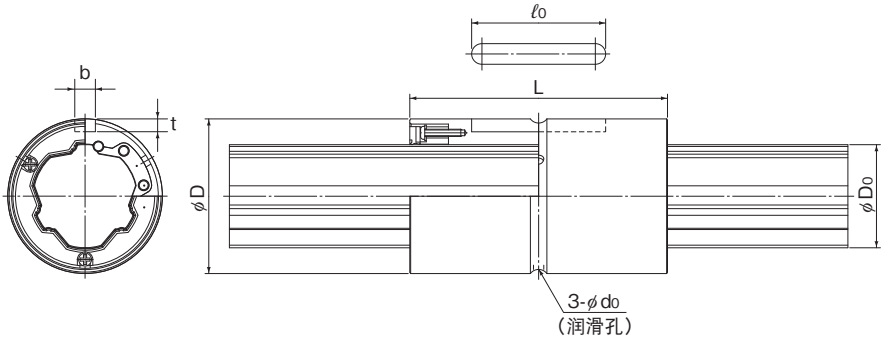

公称型号	花键母尺寸							
	外径		长度		键槽尺寸			润滑孔
	D	公差	L	公差	b H8	t +0.1 0	ℓ_0	d_0
SLS25	37	0	60	0	5	3	33	2
SLS25L			70					
SLS30	45	-0.016	70		7	4	41	3
SLS30L			80					
SLS40	60	0	90		10	4.5	55	3
SLS40L			100					
SLS50	75	-0.019	100		15	5	60	4
SLS50L			112					
SLS60	90	0	127		18	6	68	4
SLS60L			140					
SLS70	100	-0.022	110	18	6	68	4	
SLS70L			135					
SLS80	120	0	140	20	7	80	5	
SLS80L			155					
SLS100	140	0	160	28	9	93	5	
SLS100L			185					

公称型号的构成例

2 SLS50 UU CL +700L P K

公称型号

 旋转方向
 间隙标记
 (※2)

 花键轴的标识 (※4)
 精度标记 (※3)

防尘附件标记 (※1)

 花键轴总长度 (※5)
 (单位mm)

1根轴上花键母的个数 (只有1个时无标识)

 (※1)参照 [A3-120](#)。(※2)参照 [A3-30](#)。(※3)参照 [A3-34](#)。(※4)参照 [A3-46](#)。(※5)参照 [A3-115](#)。

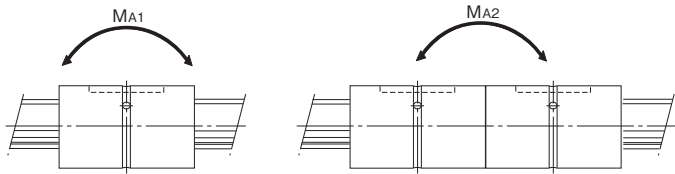

单位：mm

	基本额定扭矩		基本额定载荷		静态容许力矩		质量	
	C_T N·m	C_{GT} N·m	C kN	C_G kN	M_{A1} N·m	M_{A2} N·m	花键母 kg	花键轴 kg/m
	219.9	306.8	18.2	22.5	136	851	0.15	3.51
	261.9	394.5	21.7	29.0	220	1203	0.18	
	366.5	513.3	25.4	31.5	233	1341	0.30	5.05
	416.4	616.0	28.9	37.8	330	1803	0.34	
	818.9	1135.4	42.8	52.5	520	2801	0.69	9.18
	890.0	1277.3	46.5	59.1	652	3529	0.79	
	1373.4	1783.1	57.6	66.2	687	4156	1.30	14.45
	1571.2	2165.2	65.9	80.4	996	5349	1.47	
	2506.7	3321.0	87.8	103.0	1452	7733	2.25	21.23
	2723.2	3736.2	95.3	115.8	1820	9570	2.50	
	2986.3	3474.7	89.7	92.5	1038	6392	2.13	28.57
	3708.4	4738.2	111.4	126.1	1867	10135	2.71	
	4664.6	5477.4	122.8	127.7	1739	11482	4.22	37.49
	5195.3	6390.4	136.8	148.9	2327	14491	4.77	
	8922.3	10211.6	188.2	190.7	3155	19118	5.20	58.97
	10424.4	12764.6	219.8	238.4	4816	26463	6.22	