

SR

Radial Type LM Guide Model SR

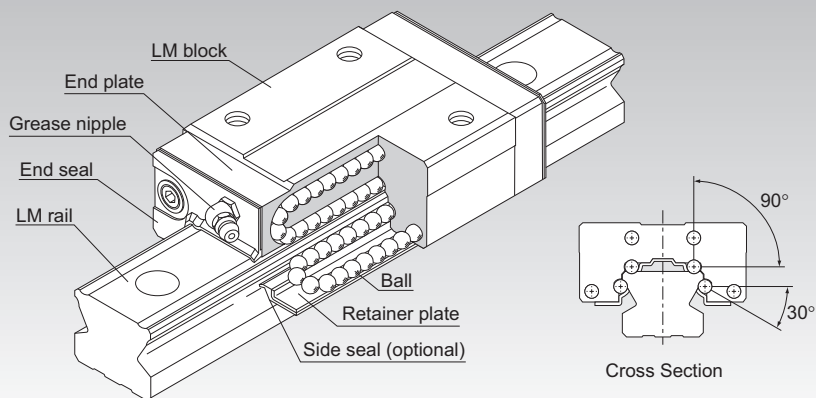

Selection Criteria **A1-10**

Design Highlights **A1-478**

Options **A1-503**

Model No. **A1-571**

Handling Precautions **A1-577**

Accessories for Lubrication **A24-1**

Mounting Procedure **B1-89**

Equivalent Moment Factor **A1-43**

Rated Loads in All Directions **A1-61**

Equivalent Factor in Each Direction **A1-63**

Radial Clearance **A1-74**

Accuracy Standards **A1-79**

Shoulder Height of the Mounting Base and the Corner Radius **A1-487**

Reference Error Tolerance for the Mounting Surface **A1-494**

Dimensions of Each Model with Options Attached **A1-517**

Structure and Features

Balls roll in four rows of raceways precision-ground on an LM rail and an LM block, and endplates incorporated in the LM block allow the balls to circulate. Since a retainer plate holds the balls, they will not fall off even if the LM block is removed from the LM rail. The low height of the LM block makes it highly rigid, achieving stable, high-precision linear motion.

Compact with Large Load Capacity

Since it is a compactly designed model that has a low cross-sectional height and a ball contact structure that is suited to large loads in the radial direction, this model is optimal for horizontal guide units.

Mounting Accuracy can Easily be Achieved

Since this self-adjusting model is capable of easily absorbing accuracy error in parallelism and level between two rails, it achieves highly accurate and smooth motion.

Low Noise

The end plate installed at each end of the LM block is designed to ensure the smooth and quiet circulation of balls at the turning areas.

High Durability

Balls do not undergo differential slip even under a preload or excessive biased load. Due to the product's high wear resistance, it maintains long-term accuracy.

Stainless Steel Type also Available

A special type whose LM block, LM rail, and balls are made of stainless steel is also available.

Types and Features

Models SR-W/T

With this type, the LM block has a smaller width (W) and tapped holes.

Dimensional Table⇒ [A1-216](#)

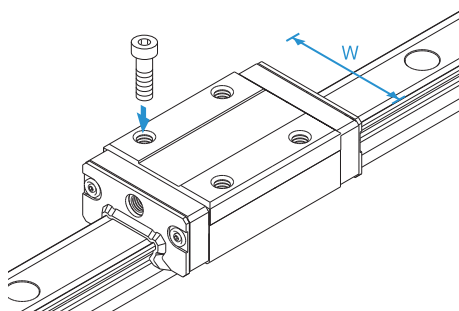

Model SR-V

This is a space-saving type whose LM block has the same cross-sectional shape as the Model SR-W, but it has a smaller overall LM block length (L).

Dimensional Table⇒ [A1-216](#)

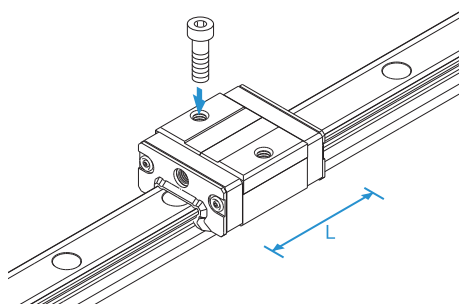

Model SR-TB

The LM block has the same height as the Model SR-W, and the flange of the LM block has through holes. It is used in places where the table cannot have through holes for mounting bolts.

Dimensional Table⇒ [A1-218](#)

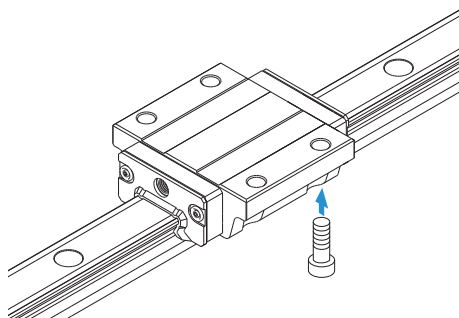

Model SR-SB

This is a space-saving type whose LM block has the same cross-sectional shape as model SR-TB, but has a smaller overall LM block length (L).

Dimensional Table → **A1-218**

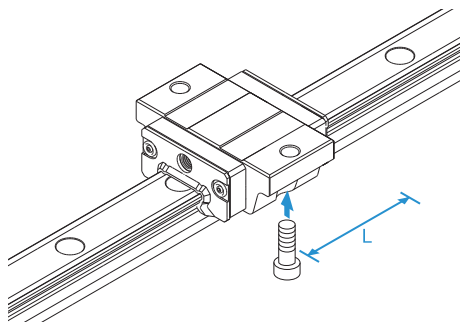

LM Guide

Characteristics of Model SR

When compared to models with a contact angle of 45° , model SR demonstrates the following excellent characteristics. By taking advantage of these characteristics, you will be able to design and manufacture highly accurate and highly rigid machines or equipment.

Difference in Load Rating and Service Life

Since SR has a contact angle of 90° , its rated load and service life are different from models with a contact angle of 45° . When comparing model SR with a model that has a contact angle of 45° and when the same radial load is applied to the two models with the same ball diameter as shown in the figure below, the load applied to SR is 70% of the other model. As a result, the service life of SR is more than twice that of the other model.

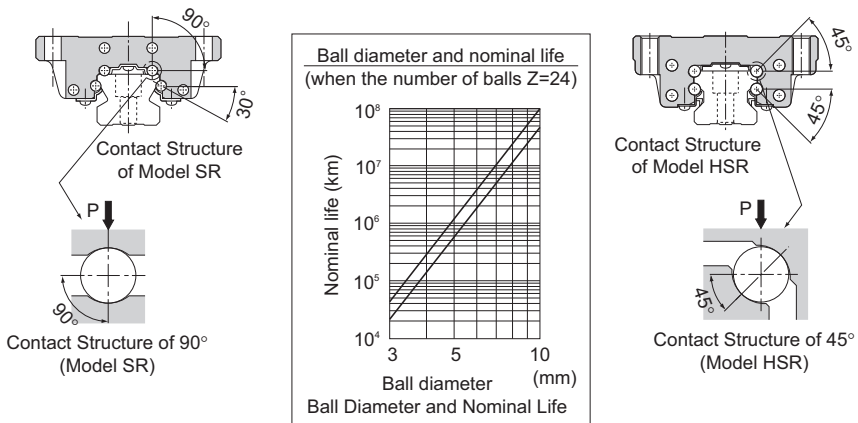

Fig. 1

Difference in Accuracy

If a machining error (grinding error) occurs in the LM rail or LM block, it will affect the running accuracy. Assuming that there is a machining error of Δ on the raceway, the error in the radial direction is 1.4 times greater in a model with a contact angle of 45° (model HSR) than in a model with a contact angle of 90° (model SR). For the horizontal direction, the error in a model with a contact angle of 45° is 1.22 times greater than that of a model with a contact angle of 30° .

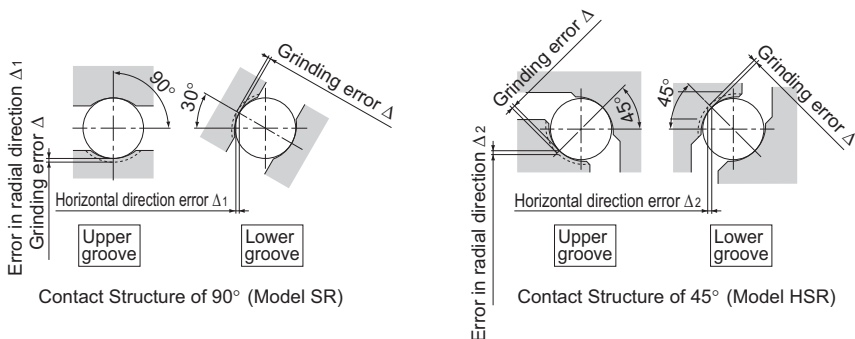

Fig. 2: Machining Error and Accuracy

Difference in Rigidity

The 90° contact angle adopted by Model SR is also different from the 45° contact angle in terms of rigidity. Accordingly, Model SR is better suited to applications that require high rigidity in the radial direction. The figure below shows the difference in radial load and displacement.

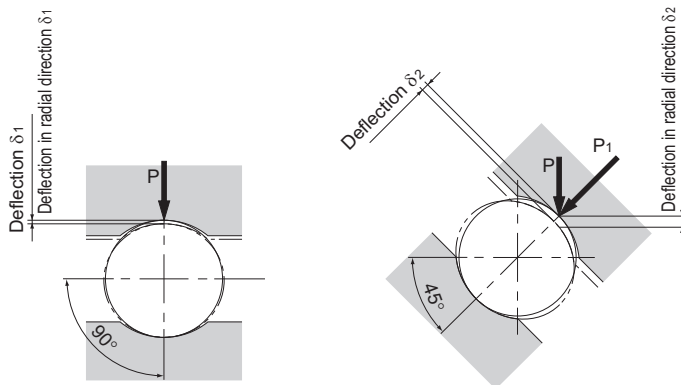

Fig. 3: Deflection Under a Radial Load

Load and deflection when contact angles are not the same ($D_a = 6.35$ mm)
(deflection per ball)

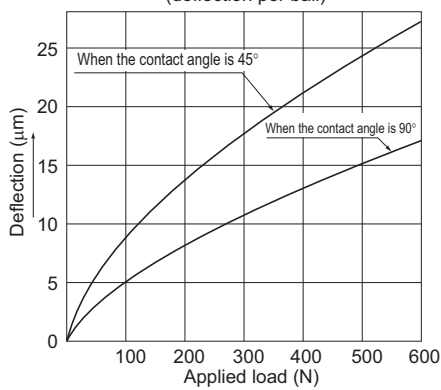

Fig. 4: Radial Load and Deflection

Conclusion

The 90° contact structure of the Model SR makes it ideal for locations where the load applied is mostly radial, locations where radial rigidity is required, and locations where accurate motion is demanded in the vertical and horizontal directions.

However, if the reverse-radial load, the lateral load, or the moment is large, we recommend Model HSR, which has a contact angle of 45° (4-way equal load).

Models SR-W, SR-WM, SR-V, SR-VM, and SR-T

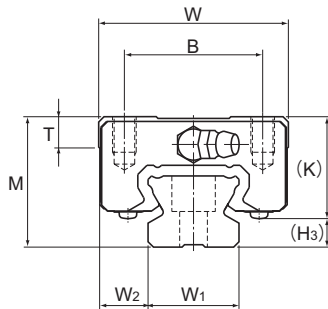

Model No.	Outer dimensions			LM block dimensions										H ₃
	Height	Width	Length	B	C	S×ℓ	L ₁	T	K	N	E	Grease nipple		
	M	W	L	B	C	S×ℓ	L ₁	T	K	N	E		H ₃	
SR 15V/VM SR 15W/WM	24	34	40.4 57	26	— 26	M4×7	22.9 39.5	5.7	18.2	6	5.5	PB1021B	5.8	
SR 20V/VM SR 20W/WM	28	42	47.3 66.2	32	— 32	M5×8	27.8 46.7	7.2	22	6	12	B-M6F	6	
SR 25V/VM SR 25W/WM	33	48	59.2 83	35	— 35	M6×9	35.2 59	7.7	26	7	12	B-M6F	7	
SR 30V/VM SR 30W/WM	42	60	67.9 96.8	40	— 40	M8×12	40.4 69.3	8.5	32.5	8	12	B-M6F	9.5	
SR 35V/VM SR 35W/WM	48	70	77.6 111	50	— 50	M8×12	45.7 79	12.5	36.5	8.5	12	B-M6F	11.5	
SR 45W	60	86	126	60	60	M10×15	90.5	15	47.5	11.5	16	B-PT1/8	12.5	
SR 55W	68	100	156	75	75	M12×20	117	16.7	54.5	12	16	B-PT1/8	13.5	
SR 70T	85	126	194.6	90	90	M16×25	147.6	24.5	70	12	16	B-PT1/8	15	
SR 85T	110	156	180	100	80	M18×30	130	25.5	91.5	27	12	A-PT1/8	18.5	
SR 100T	120	178	200	120	100	M20×35	150	29.5	101	32	12	A-PT1/8	19	
SR 120T	110	205	235	160	120	M20×35	180	24	95	14	13.5	B-PT1/4	15	
SR 150T	135	250	280	200	160	M20×35	215	24	113	17	13.5	B-PT1/4	22	

Model number coding

SR25 W 2 UU C0 M +1240L Y P T M - II

Model number	Type of LM block	Contamination protection accessory symbol (*1)	Stainless steel LM block	LM rail length (in mm)	Applied to only 15 and 25	Stainless steel LM rail	Symbol for No. of rails used on the same plane (*4)
	No. of LM blocks used on the same rail	Radial clearance symbol (*2) Normal (No symbol) Light preload (C1) Medium preload (C0)				Symbol for LM rail jointed use	
						Accuracy symbol (*3) Normal grade (No Symbol)/High accuracy grade (H) Precision grade (P)/Super precision grade (SP) Ultra precision grade (UP)	

(*1) See contamination protection accessory on **A1-543**. (*2) See **A1-74**. (*3) See **A1-79**. (*4) See **A1-13**.

Note) This model number indicates that a single-rail unit constitutes one set. (i.e., required number of sets when 2 rails are used in parallel is 2 at a minimum.)

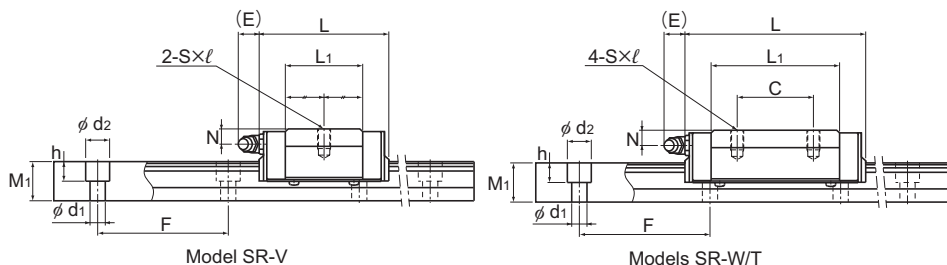

Unit: mm

	LM rail dimensions					Basic load rating			Static permissible moment kN·m*					Mass	
	Width W_1 ±0.05	Height W_2	Pitch M_1	Pitch F	Length* $d_1 \times d_2 \times h$ Max	C kN	C_0 kN	M_A		M_B		M_C	LM block kg	LM rail kg/m	
								1 block	Double blocks	1 block	Double blocks	1 block			
15	9.5	12.5	60	3.5×6×4.5	(1240) 3000	9.1 13.8	11.7 20.5	0.0344 0.0984	0.234 0.551	0.0215 0.0604	0.149 0.343	0.0694 0.122	0.12 0.2	1.2	
20	11	15.5	60	6×9.5×8.5	(1480) 3000	13.4 19.2	17.2 28.6	0.064 0.167	0.396 0.887	0.0397 0.102	0.25 0.55	0.135 0.224	0.2 0.3	2.1	
23	12.5	18	60	7×11×9	(2020) 3000	21.6 30.9	26.8 44.7	0.125 0.326	0.773 1.74	0.0774 0.2	0.488 1.08	0.245 0.408	0.3 0.4	2.7	
28	16	23	80	7×11×9	(2520) 3000	29.5 45.6	34.4 64.4	0.173 0.564	1.15 2.92	0.108 0.346	0.735 1.8	0.376 0.703	0.5 0.8	4.3	
34	18	27.5	80	9×14×12	(2520) 3000	40.9 60.4	46.7 81.8	0.275 0.785	1.79 4.27	0.171 0.482	1.14 2.65	0.615 1.08	0.8 1.2	6.4	
45	20.5	35.5	105	11×17.5×14	3000	80.4	107	1.17	6.34	0.721	3.94	1.89	2.2	11.3	
48	26	38	120	14×20×17	3000	136	179	2.61	13	1.6	8.05	3.33	3.6	12.8	
70	28	47	150	18×26×22	3000	226	282	5.03	25.7	3.09	15.9	7.47	7	22.8	
85	35.5	65.5	180	18×26×22	3000	120	224	2.54	15.1	1.25	7.47	5.74	10.1	34.9	
100	39	70.3	210	22×32×25	3000	148	283	3.95	20.9	1.95	10.3	8.55	14.1	46.4	
114	45.5	65	230	26×39×30	3000	279	377	5.83	32.9	2.87	16.2	13.7	—	—	
144	53	77	250	33×48×36	3000	411	537	9.98	55.8	4.92	27.5	24.3	—	—	

Note1) The maximum length under "Length*" indicates the standard maximum length of an LM rail. (See [A1-220](#).)
Static permissible moment* 1 block: the static permissible moment with one LM block

Double blocks: static permissible moment when two LM blocks are in close contact with each other
Total block length L : The total block length L shown in the table is the length with the dust proof parts, code UU or SS.
If other contamination protection accessories or lubricant equipment are installed, the total block length will increase.
(See [A1-517](#) or [A1-539](#))

The M in the model number symbol indicates that the LM block, LM rail and balls are made of stainless steel.
The stainless steel provides excellent corrosion and environmental resistance.
Models SR85T, 100T, 120T and 150T are built to order.

Note2) Models SR85T and 100T include a grease nipple on the side face of the LM block. Contact THK for details.
Note2) For models SR15 and 25, two types of rails with different mounting hole dimensions are offered (see Table 1).
When replacing this model with model SSR, pay attention to the mounting hole dimension of the LM rail.
Contact THK for details.

Note3) The basic load rating in the dimension table is for a load in the radial direction. Use Table 7 on [A1-61](#) to calculate the load rating for loads in the reverse radial direction or lateral direction.

Table 1: Rail Mounting Hole Dimensions

Model No.	Standard rail	Semi-standard rail
SR 15	For M3 (no symbol)	For M4 (symbol Y)
SR 25	For M6 (symbol Y)	For M5 (no symbol)

Models SR-TB, SR-TBM, SR-SB, and SR-SBM

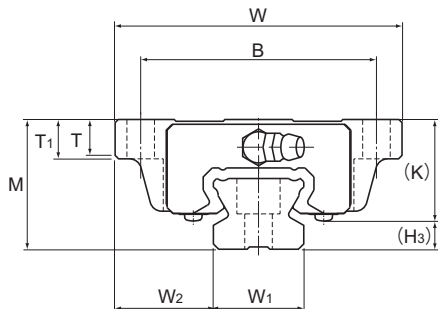

Model No.	Outer dimensions			LM block dimensions										Grease nipple	H ₃
	Height	Width	Length	B	C	H	L ₁	T	T ₁	K	N	E			
	M	W	L												
SR 15SB/SBM SR 15TB/TBM	24	52	40.4 57	41	— 26	4.5	22.9 39.5	6.1	7	18.2	6	5.5	PB1021B	5.8	
SR 20SB/SBM SR 20TB/TBM	28	59	47.3 66.2	49	— 32	5.5	27.8 46.7	8	9	22	6	12	B-M6F	6	
SR 25SB/SBM SR 25TB/TBM	33	73	59.2 83	60	— 35	7	35.2 59	9.1	10	26	7	12	B-M6F	7	
SR 30SB/SBM SR 30TB/TBM	42	90	67.9 96.8	72	— 40	9	40.4 69.3	8.7	10	32.5	8	12	B-M6F	9.5	
SR 35SB/SBM SR 35TB/TBM	48	100	77.6 111	82	— 50	9	45.7 79	11.2	13	36.5	8.5	12	B-M6F	11.5	
SR 45TB	60	120	126	100	60	11	90.5	12.8	15	47.5	11.5	16	B-PT1/8	12.5	
SR 55TB	68	140	156	116	75	14	117	15.3	17	54.5	12	16	B-PT1/8	13.5	

Model number coding

SR25 TB 2 UU C1 +1200L Y H T -II

Model number

Type of LM block

Contamination protection accessory symbol (*1)

LM rail length (in mm)

Applied to only 15 and 25

Symbol for LM rail jointed use

Symbol for No. of rails used on the same plane (*4)

No. of LM blocks used on the same rail

Radial clearance symbol (*2)
Normal (No symbol)
Light preload (C1)
Medium preload (C0)

Accuracy symbol (*3)
Normal grade (No Symbol)/High accuracy grade (H)
Precision grade (P)/Super precision grade (SP)
Ultra precision grade (UP)

(*1) See contamination protection accessory on **A1-543**. (*2) See **A1-74**. (*3) See **A1-79**. (*4) See **A1-13**.

Note) This model number indicates that a single-rail unit constitutes one set. (i.e., required number of sets when 2 rails are used in parallel is 2 at a minimum.)

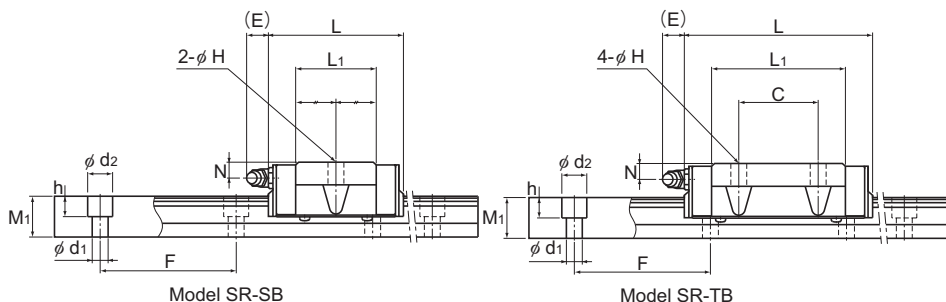

Unit: mm

LM rail dimensions						Basic load rating		Static permissible moment kN·m*					Mass	
Width W_1 ±0.05	Height M_1	Pitch F	Length* $d_1 \times d_2 \times h$ Max	C kN	C_0 kN	M_A		M_B		M_C	LM block kg	LM rail kg/m		
						1 block	Double blocks	1 block	Double blocks	1 block				
15	18.5	12.5	60	3.5×6×4.5 (1240) 3000	9.1	11.7	0.0344	0.234	0.0215	0.149	0.0694	0.15 0.2	1.2	
					13.8	20.5	0.0984	0.551	0.0604	0.343	0.122			
20	19.5	15.5	60	6×9.5×8.5 (1480) 3000	13.4	17.2	0.064	0.396	0.0397	0.25	0.135	0.3 0.4	2.1	
					19.2	28.6	0.167	0.887	0.102	0.55	0.224			
23	25	18	60	7×11×9 (2020) 3000	21.6	26.8	0.125	0.773	0.0774	0.488	0.245	0.4 0.6	2.7	
					30.9	44.7	0.326	1.74	0.2	1.08	0.408			
28	31	23	80	7×11×9 (2520) 3000	29.5	34.4	0.173	1.15	0.108	0.735	0.376	0.8 1.1	4.3	
					45.6	64.4	0.564	2.92	0.346	1.8	0.703			
34	33	27.5	80	9×14×12 (2520) 3000	40.9	46.7	0.275	1.79	0.171	1.14	0.615	1 1.5	6.4	
					60.4	81.8	0.785	4.27	0.482	2.65	1.08			
45	37.5	35.5	105	11×17.5×14 3000	80.4	107	1.17	6.34	0.721	3.94	1.89	2.5	11.3	
48	46	38	120	14×20×17 3000	136	179	2.61	13	1.6	8.05	3.33	4.2	12.8	

Note1) The maximum length under "Length*" indicates the standard maximum length of an LM rail. (See **A1-220**.)

Static permissible moment* 1 block: the static permissible moment with one LM block

Double blocks: static permissible moment when two LM blocks are in close contact with each other

Total block length L

: The total block length L shown in the table is the length with the dust proof parts, code UU or SS. If other contamination protection accessories or lubricant equipment are installed, the total block length will increase.

(See **A1-517** or **A1-539**)

The M in the model number symbol indicates that the LM block, LM rail and balls are made of stainless steel.

The stainless steel provides excellent corrosion and environmental resistance.

Note2) For models SR15 and 25, two types of rails with different mounting hole dimensions are offered (see Table 1).

When replacing this model with model SSR, pay attention to the mounting hole dimension of the LM rail.

Contact THK for details.

Note3) The basic load rating in the dimension table is for a load in the radial direction. Use Table 7 on **A1-61** to calculate the load rating for loads in the reverse radial direction or lateral direction.

Table 1: Rail Mounting Hole Dimensions

Model No.	Standard rail	Semi-standard rail
SR 15	For M3 (no symbol)	For M4 (symbol Y)
SR 25	For M6 (symbol Y)	For M5 (no symbol)

Standard Lengths and Maximum Lengths of LM Rails

Table 1 shows the standard lengths and the maximum lengths of model SR variations. If the maximum length of the desired LM rail exceeds these values, jointed rails will be used. Contact THK for details. For special rail lengths, it is recommended to use a value corresponding to the G and g dimensions from the table. As the G and g dimensions increase, this portion becomes less stable, and the accuracy performance is severely impacted.

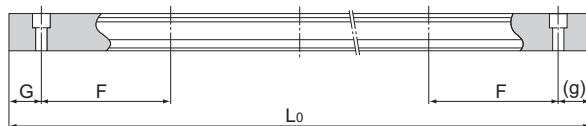

Table 1: Standard Lengths and Maximum Lengths of LM Rails for Model SR

Unit: mm

Model No.	SR 15	SR 20	SR 25	SR 30	SR 35	SR 45	SR 55	SR 70	SR 85	SR 100	SR 120	SR 150
LM rail standard lengths (L_0)	160	220	220	280	280	570	780	1270	1520	1550	1700	1600
	220	280	280	360	360	675	900	1570	2060	1970	2390	2100
	280	340	340	440	440	780	1020	2020	2600	2600		
	340	400	400	520	520	885	1140	2620				
	400	460	460	600	600	990	1260					
	460	520	520	680	680	1095	1380					
	520	580	580	760	760	1200	1500					
	580	640	640	840	840	1305	1740					
	640	700	700	920	920	1410	1860					
	700	760	760	1000	1000	1515	1980					
	760	820	820	1080	1080	1725	2100					
	820	940	940	1160	1160	1830	2220					
	940	1000	1000	1240	1240	1935	2340					
	1000	1060	1060	1320	1320	2040	2460					
	1060	1120	1120	1400	1400	2145	2580					
	1120	1180	1180	1480	1480	2250	2700					
	1180	1240	1240	1640	1640	2355	2820					
	1240	1300	1300	1720	1720	2460	2940					
	1300	1360	1360	1800	1800	2565						
	1360	1420	1420	1880	1880	2670						
	1420	1480	1480	1960	1960	2775						
	1480	1540	1540	2040	2040	2880						
	1540	1600	1600	2120	2120	2985						
		1660	1660	2200	2200							
		1720	1720	2280	2280							
		1780	1780	2360	2360							
		1840	1840	2440	2440							
	1900	1900	2520	2520								
	1960	1960	2600	2600								
	2020	2020	2680	2680								
	2080	2080	2760	2760								
	2140		2840	2840								
		2200	2920	2920								
		2260										
		2320										
		2380										
		2440										
Standard pitch F	60	60	60	80	80	105	120	150	180	210	230	250
G, g	20	20	20	20	20	22.5	30	35	40	40	45	50
Max length	3000 (1240)	3000 (1480)	3000 (2020)	3000 (2520)	3000 (2520)	3000	3000	3000	3000	3000	3000	3000

Note1) The maximum length varies with accuracy grades. Contact THK for details.

Note2) If jointed rails are not allowed and a greater length than the maximum values above is required, contact THK.

Note3) Those model numbers including and greater than SR85T are semi-standard models. If desiring these models, contact THK.

Note4) The figures in the parentheses indicate the maximum lengths of stainless steel made models.

Tapped-Hole Type LM Rail

Model SR rails also include a type where the LM rail is tapped from the bottom. This type is useful when mounting from the bottom of the base and when increased contamination protection is desired.

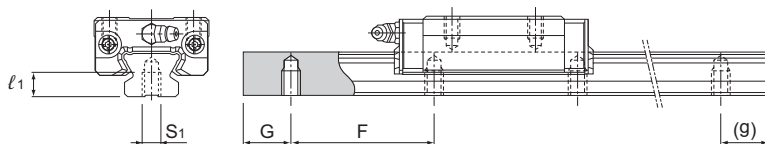
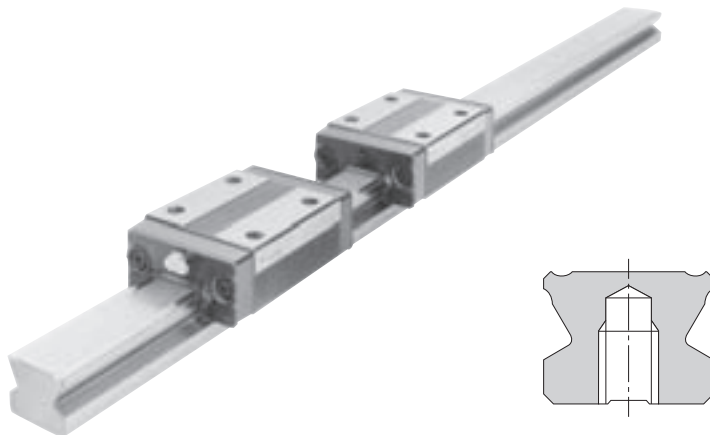

- (1) A tapped-hole LM rail is available only for Precision or lower grades.
- (2) For standard pitches of the taps and the G and g dimensions, see Table 1 on [A1-220](#).

Table 2: Dimensions of the LM Rail Tap Unit: mm

Model No.	S ₁	Effective tap depth l_1
SR 15	M5	7
SR 20	M6	9
SR 25	M6	10
SR 30	M8	14
SR 35	M8	16
SR 45	M12	20
SR 55	M14	22

Model number coding

SR30W2UU+1000LH K

T
Symbol for
tapped-hole LM rail type