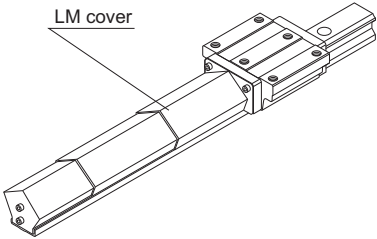

Dedicated LM Cover

- For the supported models, see the table of options by model number on [A1-460](#).
- For the dedicated LM cover dimensions, see [A1-513](#).

Item name	Schematic diagram / mounting location	Purpose/location of use
<p>Dedicated LM Cover</p>		<p>Used in locations exposed to dust or cutting chips Used in locations where high temperature foreign material such as flying spatter</p>

LM Cover

[Dedicated LM Cover TPH for Model HSR]

The tables below show the dimensions of dedicated LM cover TPH for model HSR. Specify the corresponding model number of the desired bellows from the table.

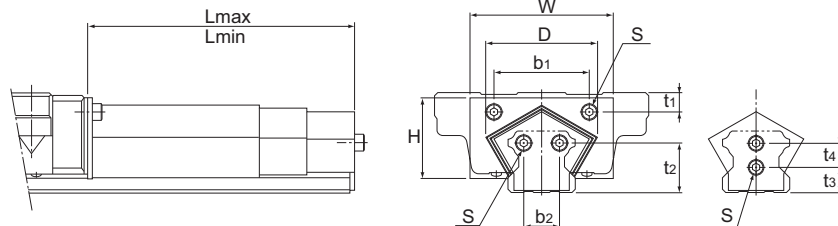

Models HSR25 and 30

Unit: mm

Model No.	Main dimensions											Supported model numbers	
	W	D (max)	H	b ₁	t ₁	b ₂	t ₂	t ₃	t ₄	Mounting bolt S			
TPH	25	55	42	28	30	7	—	—	10	8	M3×6ℓ	HSR	25
	30	60	48	34	40	8	—	—	11	10	M4×8ℓ		30
	35	70	55	38	40	9	14	23	—	—	M4×8ℓ		35
	45	90	75	48	58	10	20	29	—	—	M5×10ℓ		45
	55	100	88	55	66	11	26	35	—	—	M5×10ℓ		55

Unit: mm

Unit: mm

Model No.	Stage	L		Stroke	
		min	max		
TPH	25	3	200	530	330
		3	150	380	230
		3	100	230	130
	30	3	250	680	430
		3	200	530	330
		3	150	380	230
	35	3	300	830	530
		3	250	680	430
		3	200	530	330
3	150	380	230		

Model No.	Stage	L		Stroke	
		min	max		
TPH	45	3	350	980	630
		3	300	830	530
		3	250	680	430
	55	3	200	530	330
		4	400	1460	1060
		4	350	1330	980
4	300	1060	760		
4	250	860	610		

Note1) For lubrication when using the dedicated LM cover, contact THK.

Note2) When using the dedicated LM cover, the LM block and LM rail need to be machined so that the bellows can be mounted. Be sure to indicate that the dedicated bellows is required when ordering the LM Guide.

Model number coding

TPH55 - 400/1460

Model number of LM cover for HSR55 Lmax (cover length when extended)

Lmin (cover length when compressed)