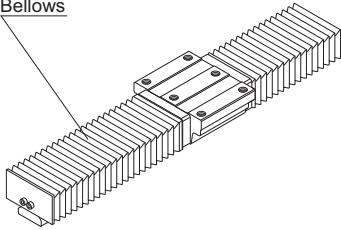

## Dedicated Bellows

- For the supported models, see the table of options by model number on [A1-504](#).
- For the dimensions of the dedicated bellows, see [A1-547](#) to [A1-558](#).

Item name	Schematic diagram/mounting location	Purpose/location of use
<b>Dedicated bellows</b>		Used in locations exposed to dust or cutting chips

## Bellows

### Dedicated Bellows JSH for Model SHS

The table below shows the dimensions of dedicated bellows JSH for model SHS. Specify the corresponding model number of the desired bellows from the table.

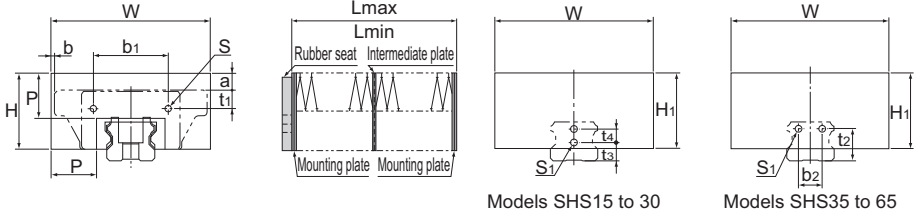

Models SHS15 to 30

Models SHS35 to 65

Unit: mm

Model No.	Main dimensions													Supported model numbers	
	W	H	H <sub>1</sub>	P	b <sub>1</sub>	t <sub>1</sub>			b <sub>2</sub>	t <sub>2</sub>	t <sub>3</sub>	t <sub>4</sub>			
						C	V	R							
JSH	15	53	26	26	15	22.4	4	4	8	—	—	8	—	SHS	15
	20	60	30	30	17	27.6	7.5	7.5	—	—	8	6	20		
	25	75	36	36	20	38	9.1	9.1	13.1	—	—	9	7		25
	30	80	38	38	20	44	11	11	14	—	—	11	8		30
	35	86	40.5	40.5	20	50	11	11	18	20	21.5	—	—		35
	45	97	46	46	20	64.6	13.5	13.5	23.5	26	26.5	—	—		45
	55	105	48	48	20	68	13	13	23	30	31.5	—	—		55
	65	126	63	63	25	80	18	18	—	34	45	—	—		65

Unit: mm

Supported model numbers	Other dimensions									$\frac{A}{\frac{L_{max}}{L_{min}}}$
	Mounting bolt		a			b				
	S	S <sub>1</sub>	C	V	R	C	V	R		
SHS	15	*M2×10 $l$	M4×8 $l$	5	5	1	3	9.5	9.5	5
	20	M2.6×10 $l$	M3×6 $l$	5	5	—	-1.5	8	—	6
	25	M3×12 $l$	M3×6 $l$	6	6	2	2.5	13.5	13.5	7
	30	M3×15 $l$	M3×6 $l$	3	3	0	-5	10	10	7
	35	M4×15 $l$	M4×8 $l$	0	0	-7	-7	8	8	7
	45	M4×15 $l$	M4×8 $l$	-5	-5	-15	-11.7	5.5	5.5	7
	55	M5×20 $l$	M5×10 $l$	-9	-9	-19	-17.5	2.5	2.5	7
	65	M6×25 $l$	M6×12 $l$	-8	-8	—	-22	0	—	9

\* Use tapping screws as the mounting screws on the LM block side of the JSH15.

Note1) Please contact THK if you will be using the dedicated bellows in anything other than a horizontal orientation (i.e., vertical, wall-mounted, or inverted), or if you require heat-resistant specifications.

Note2) When using the bellows, lubrication is possible through methods such as a side nipple.

Note3) When using the dedicated bellows, the LM block and LM rail need to be machined so that the bellows can be mounted. Be sure to indicate that the dedicated bellows is required when ordering the LM Guide.

#### Model number coding

### JSH35 - 60/420

Model number of bellows for SHS35      Dimensions of the bellows (length when compressed / length when extended)

Note) The length of the bellows is calculated as follows.

$$L_{min} = \frac{S}{(A-1)} \quad S: \text{Stroke length (mm)}$$

$$L_{max} = L_{min} \cdot A \quad A: \text{Extension rate}$$

### Dedicated Bellows JSSR-X for Model SSR

The table below shows the dimensions of dedicated bellows JSSR-X for model SSR. Specify the corresponding model number of the desired bellows from the table.

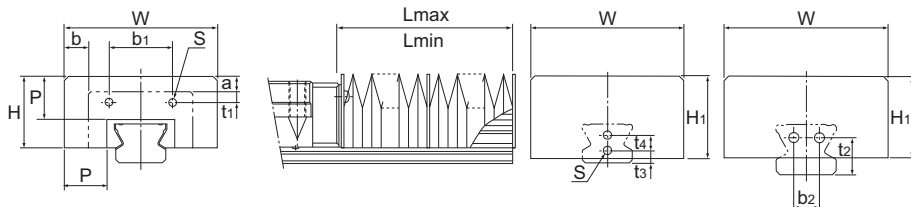

Models SSR15X to 25X    Models SSR30X and 35X

Unit: mm

Model No.	Main dimensions													Supported model numbers				
	W	H	H <sub>1</sub>	P	b <sub>1</sub>	t <sub>1</sub>	b <sub>2</sub>	t <sub>2</sub>	t <sub>3</sub>	t <sub>4</sub>	Mounting bolt S	a	b		A ( $\frac{L_{max}}{L_{min}}$ )			
													XW/XV			XTB		
JSSR	15X	51	24	26	15	20.5	4.7	—	—	8	—	M3×5ℓ	5	8.5	-0.5	5	SSR	15X
	20X	58	26	30	15	25	4.2	—	—	6	6	M3×5ℓ	4	8	-0.5	5		20X
	25X	71	33	38	20	29	5	—	—	6	7	M3×5ℓ	7	11.5	-1	7		25X
	30X	76	37.5	37.5	20	35	9	12	17	—	—	M4×6ℓ	3	8	—	7		30X
	35X	84	39	39	20	44	7	14	20	—	—	M5×10ℓ	2	7	—	7		35X

Note1) Please contact THK if you will be using the dedicated bellows in anything other than a horizontal orientation (i.e., vertical, wall-mounted, or inverted), or if you require heat-resistant specifications.

Note2) When using the bellows, lubrication is possible through methods such as a side nipple.

Note3) When using the dedicated bellows, the LM block and LM rail need to be machined so that the bellows can be mounted. Be sure to indicate that the dedicated bellows is required when ordering the LM Guide.

#### Model number coding

### JSSR35X - 60/420

Model number of bellows for SSR35X

Dimensions of the bellows (length when compressed / length when extended)

Note) The length of the bellows is calculated as follows.

$$L_{min} = \frac{S}{(A-1)} \quad S: \text{Stroke length (mm)}$$

$$L_{max} = L_{min} \cdot A \quad A: \text{Extension rate}$$

### Model JSV Dedicated Bellows for Models SVR/SVS/NR-X/NRS-X

For models SVR/SVS and NR-X/NRS-X, the model JSV simplified bellows is available. Contact THK for details.

## Options

## Dedicated Bellows

## Dedicated Bellows JSHW for Model SHW

The table below shows the dimensions of dedicated bellows JSHW for model SHW. Specify the corresponding model number of the desired bellows from the table.

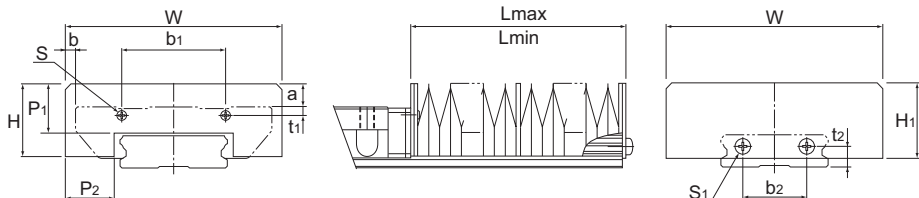

Unit: mm

Model No.	Main dimensions										Supported model numbers	
	W	H	H <sub>1</sub>	P <sub>1</sub>	P <sub>2</sub>	b <sub>1</sub>	t <sub>1</sub>	b <sub>2</sub>	t <sub>2</sub>			
JSHW	17	68	22	23	15	15.4	39	2.6	18	6	SHW	17
	21	75	25	26	17	17	35.8	2.9	22	7		21
	27	85	33.5	33.5	20	20	25	3.5	20	10		27
	35	120	35	35	20	20	75	7.5	40	13		35
	50	164	42	42	20	20	89.4	14	50	16		50

Unit: mm

Model No.	Other dimensions						A ( $\frac{L_{max}}{L_{min}}$ )
	Mounting bolt		a	b			
	*S	S <sub>1</sub>		Model CA	Model CR		
JSHW	17	M2×4ℓ	M3×6ℓ	8	4	9	5
	21	M2×5ℓ	M3×6ℓ	8	3.5	10.5	6
	27	M2.6×6ℓ	M3×6ℓ	10	2.5	11.5	7
	35	M3×8ℓ	M3×6ℓ	6	0	10	7
	50	M4×12ℓ	M4×8ℓ	—	1	17	7

Note1) Please contact THK if you will be using the dedicated bellows in anything other than a horizontal orientation (i.e., vertical, wall-mounted, or inverted), or if you require heat-resistant specifications.

Note2) For lubrication when using the dedicated bellows, contact THK.

Note3) For the mounting bolts marked with "\*", use tapping screws.

Note4) When using the dedicated bellows, the LM block and LM rail need to be machined so that the bellows can be mounted. Be sure to indicate that the dedicated bellows is required when ordering the LM Guide.

## Model number coding

## JSHW21 - 60/360

Model number of bellows for SHW21      Dimensions of the bellows (length when compressed / length when extended)

Note) The length of the bellows is calculated as follows.

$$L_{min} = \frac{S}{(A-1)} \quad S: \text{Stroke length (mm)}$$

$$L_{max} = L_{min} \cdot A \quad A: \text{Extension rate}$$

## Dedicated Bellows JH for Model HSR

The table below shows the dimensions of dedicated bellows JH for model HSR. Specify the corresponding model number of the desired bellows from the table.

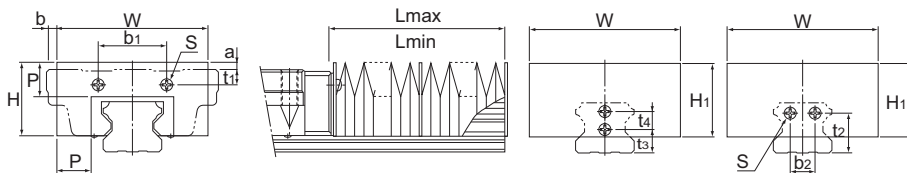

Models HSR15 to 30 Models HSR35 to 85

Unit: mm

Model No.	Main dimensions																Supported model numbers			
	W	H	H <sub>1</sub>	P	b <sub>1</sub>	t <sub>1</sub>		b <sub>2</sub>	t <sub>2</sub>	t <sub>3</sub>	t <sub>4</sub>	Mounting bolt S	a		b			$\frac{A}{L_{\max}} \left( \frac{L_{\max}}{L_{\min}} \right)$		
						A/B/C	R						A/B/C	R						
JH	15	55	27	30	15	25	2.5	6.5	—	—	10	—	*M4×8ℓ	7.5	3.5	-4	-10.5	5	HSR	15
	20	66	32	35	17	34	5	5	—	—	6	8	M3×6ℓ	7	7	-1.5	-11	6		20
	25	78	38	38	20	30	7	11	—	—	10	8	M3×6ℓ	8.5	4.5	-4	-15	7		25
	30	84	42	42	20	40	8	11	—	—	11	10	M4×8ℓ	7	4	3	-12	7		30
	35	88	43	43	20	40	9	16	14	23	—	—	M4×8ℓ	4	—	6	-9	7		35
	45	100	51	51	20	58	10	20	20	29	—	—	M5×10ℓ	—	—	10	-7	7		45
	55	108	54	54	20	66	11	21	26	35	—	—	M5×10ℓ	—	—	16	-4	7		55
	65	132	68	68	20	80	19	19	32	42	—	—	M6×12ℓ	—	—	19	-3	7		65
85	170	88	88	30	105	23	23	44	50	—	—	M6×12ℓ	—	—	22.5	-7	10	85		

Note1) For the Model JH15 mounting bolt marked with an asterisk, mounting bolts are used only on the LM rail side, while the LM block side uses M2×5 (nominal) tapping screws.

Note2) Please contact THK if you will be using the dedicated bellows in anything other than a horizontal orientation (i.e., vertical, wall-mounted, or inverted), or if you require heat-resistant specifications.

Note3) When using the bellows, lubrication is possible through methods such as using a side nipple. However, a side nipple cannot be attached to HSR15 and HSR20, so please contact THK.

Note4) When using the dedicated bellows, the LM block and LM rail need to be machined so that the bellows can be mounted. Be sure to indicate that the dedicated bellows is required when ordering the LM Guide.

### Model number coding

## JH25 - 60/420

Model number of bellows for HSR25      Dimensions of the bellows (length when compressed / length when extended)

Note) The length of the bellows is calculated as follows.

$$L_{\min} = \frac{S}{(A-1)} \quad S: \text{Stroke length (mm)}$$

$$L_{\max} = L_{\min} \cdot A \quad A: \text{Extension rate}$$

### Dedicated Bellows DH for Model HSR

For models HSR15, 20, and 25, bellows DH, which has the following features, is also available in addition to the dedicated bellows JH. Specify the corresponding model number of the desired bellows from the table.

#### ● Features

- (1) It has a width and height smaller than the conventional product so that no part of the bellows sticks out above the top face of the LM block. The extension rate is equal to or greater than that of the conventional type.
- (2) It has an intermediate plate for each crest so that it will not easily lift and the bellows can be used when mounted vertically, to a wall, or diagonally.
- (3) It is operable at high speeds, up to 120 m/min.
- (4) Since Velcro can be used to install the bellows, a regular-size model can be cut to the desired length, or two or more regular-size bellows can be joined together.
- (5) It can be installed using screws just as the Model JH. Please contact THK if you wish to use screws for installation.

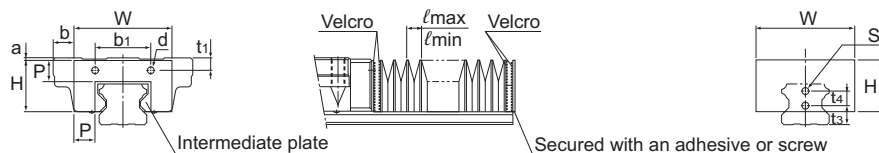

Unit: mm

Model No.	Main dimensions															Supported model numbers				
	W	H	P	b <sub>1</sub>	t <sub>1</sub>		t <sub>3</sub>	t <sub>4</sub>	d	s	a		b		l <sub>max</sub>			l <sub>min</sub>	Extension rate A	
					C	R					C	R								
DH	15X	35	19.5	8.5	25	2.5	6.5	10	—	φ2.5	φ5	0	4	6	-0.5	10	2.5	4	HSR	15
	20X	45	25	10	34	5	5	6	8	φ4	φ4	0	0	9	-0.5	13	2.5	5		20
	25X	52	29.5	12	30	7	11	10	8	φ3.5	φ3.5	0	4	9	-2	15	3	5	25	

Note1) For lubrication when using the dedicated bellows, contact THK.

Note2) When using the bellows, lubrication is possible through methods such as using a side nipple. However, a side nipple cannot be attached to HSR15 and HSR20, so please contact THK.

#### Model number coding

### DH20X - 50/250

Model number of bellows for HSR20

Dimensions of the bellows (length when compressed / length when extended)

Note) The length of the bellows is calculated as follows.

$$L_{min} = \frac{(S+2A)}{(A-1)} \quad S: \text{Stroke length (mm)}$$

$$L_{max} = (L_{min}-2)A \quad A: \text{Extension rate}$$

## Dedicated Bellows JS for Model SR

The table below shows the dimensions of dedicated bellows JS for model SR. Specify the corresponding model number of the desired bellows from the table.

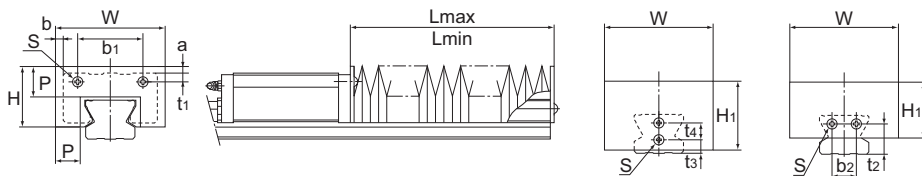

Models SR15 to 25    Models SR30 to 70

Unit: mm

Model No.	Main dimensions														Supported model numbers			
	W	H	H <sub>1</sub>	P	b <sub>1</sub>	t <sub>1</sub>	b <sub>2</sub>	t <sub>2</sub>	t <sub>3</sub>	t <sub>4</sub>	Mounting bolt S	a	b			A L <sub>max</sub> L <sub>min</sub>		
													W/V	TB/SB				
JS	15	51	24	26	15	22	3.4	—	—	8	—	M3×6ℓ	5	8.5	-0.5	5	SR	15
	20	58	26	30	15	25	4.2	—	—	6	6	M3×6ℓ	4	8	-0.5	5		20
	25	71	33	38	20	29	5	—	—	6	7	M3×6ℓ	7	11.5	-1	7		25
	30	76	37.5	37.5	20	42	5	12	17	—	—	M4×8ℓ	3	8	-7	7		30
	35	84	39	39	20	44	6.5	14	20	—	—	M5×10ℓ	1.5	7	-8	7		35
	45	95	47.5	47.5	20	60	8	22	27	—	—	M5×10ℓ	-1.5	5	-12.5	7		45
	55	108	55.5	55.5	25	70	10	24	28	—	—	M6×12ℓ	-0.5	4	-16	9		55
	70	144	67	67	30	90	13	34	35	—	—	M6×12ℓ	-3	9	—	10		70

Note1) Please contact THK if you will be using the dedicated bellows in anything other than a horizontal orientation (i.e., vertical, wall-mounted, or inverted), or if you require heat-resistant specifications.

Note2) For lubrication when using the dedicated bellows, contact THK.

Note3) When using the dedicated bellows, the LM block and LM rail need to be machined so that the bellows can be mounted. Be sure to indicate that the dedicated bellows is required when ordering the LM Guide.

### Model number coding

## JS55 - 60/540

Model number of bellows for SR55

Dimensions of the bellows (length when compressed / length when extended)

Note) The length of the bellows is calculated as follows.

$$L_{\min} = \frac{S}{(A-1)} \quad S: \text{Stroke length (mm)}$$

$$L_{\max} = L_{\min} \cdot A \quad A: \text{Extension rate}$$

### Dedicated Bellows DS for Model SR

For models SR15, 20, and 25, bellows DS, which has the following features, is also available in addition to the dedicated bellows JS. Specify the corresponding model number of the desired bellows from the table.

#### ● Features

- (1) It has a width and height smaller than the conventional product so that no part of the bellows sticks out above the top face of the LM block. The extension rate is equal to or greater than that of the conventional type.
- (2) It has an intermediate plate for each crest so that it will not easily lift and the bellows can be used when mounted vertically, to a wall, or diagonally.
- (3) It is operable at high speeds, up to 120 m/min.
- (4) Since Velcro can be used to install the bellows, a regular-size model can be cut to the desired length, or two or more regular-size bellows can be joined together.
- (5) Can be installed using screws just as bellows JS.  
In this case, a plate (thickness: 1.6 mm) must be placed between the bellows and the LM block. Please contact THK if you wish to use screws for installation.

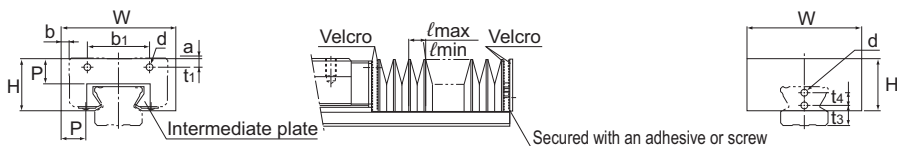

Unit: mm

Model No.	Main dimensions																Supported model numbers	
	W	H	P	b <sub>1</sub>	t <sub>1</sub>	t <sub>3</sub>	t <sub>4</sub>	d	a	b		l <sub>max</sub>	l <sub>min</sub>	Extension rate	A	E		Factor k
										W/V	TB/SB							
DS	15	38	19	10	22	3.4	8	—	3.5	0	2	-7	13	2.5	5	2	1.3	15
	20	49	22	10	25	4.2	6	6	4	0	3.5	-5	13	2.5	5	2	1.3	SR 20
	25	56	26	12	29	5	6	7	4	0	4	-8.5	15	3	5	2	1.3	25

Note1) For lubrication when using the dedicated bellows, contact THK.

Note2) When using the dedicated bellows, the LM block and LM rail need to be machined so that the bellows can be mounted. Be sure to indicate that the dedicated bellows is required when ordering the LM Guide.

#### Model number coding

### DS20 - 50/250

Model number of bellows for SR20

Dimensions of the bellows (length when compressed / length when extended)

Note) The maximum length of the bellows itself is calculated as follows.

$$L_{\max} (L_{\min}) = l_{\max} (l_{\min}) \times 200$$

Example of calculating bellows dimensions:

When the stroke of model SR20 is:  $l_s = 530$  mm

$$L_{\min} = \frac{l_s}{(A-1)} = \frac{530}{4} = 132.5 \div 135$$

$$L_{\max} = A \cdot L_{\min} = 5 \times 135 = 675$$

Number of required crests n

$$n = \frac{L_{\max}}{P \cdot k} = \frac{675}{10 \times 1.3} = 51.9 \div 52 \text{ crests}$$

$$L_{\min} = n \cdot l_{\min} + E = 52 \times 2.5 + 2 = 132$$

(E indicates the plate thickness of 2)

Therefore, the model number of the required bellows is DS20-132/675.



### Simplified Bellows JN Dedicated for Models NR/NRS

For models NR/NRS, simplified bellows are available. For greater contamination protection, attach a telescopic cover outside the bellows after the bellows are mounted as depicted in Fig. 1.

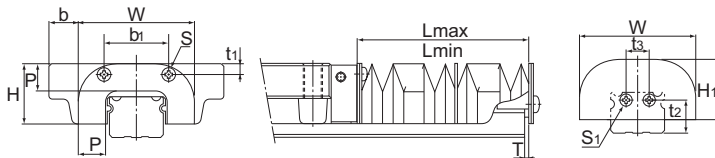

Models NR/NRS 75 to 100

Unit: mm

Model No.	Main dimensions											A ( $\frac{L_{max}}{L_{min}}$ )	Supported model numbers			
	W	H	H <sub>1</sub>	P	b <sub>1</sub>	t <sub>1</sub>	t <sub>2</sub>	t <sub>3</sub>	Mounting bolt		b				T	
									S	S <sub>1</sub>	A, LA B, LB					
JN	75	145	64	64	30	80	10.5	34.2	26	M6×12ℓ	M6×5ℓ	25	3.2	20	NR/ NRS	75
	85	156	70.5	70.5	30	110	15.5	39.5	28	M6×12ℓ	M6×5ℓ	39.5	3.2	20		85
	100	200	82	82	35	140	15	40	34	M8×16ℓ	M6×5ℓ	30	3.2	20		100

Note1) Please contact THK if you will be using the simplified bellows in anything other than a horizontal orientation (i.e. vertical, wall-mounted, or inverted), or if you require heat-resistant specifications.

Note2) When using the bellows, lubrication is possible through methods such as a side nipple.

Note3) When using the bellows, the LM block and LM rail need to be machined so that the bellows can be mounted. Be sure to indicate that the bellows is required when ordering the LM Guide.

#### Model number coding

### JN75 - 60/420

Model number of bellows for NR/NRS

Dimensions of the bellows (length when compressed / length when extended)

Note) The length of the bellows is calculated as follows.

$$L_{min} = \frac{S}{(A-1)} \quad S: \text{Stroke length (mm)}$$

$$L_{max} = L_{min} \cdot A \quad A: \text{Extension rate}$$

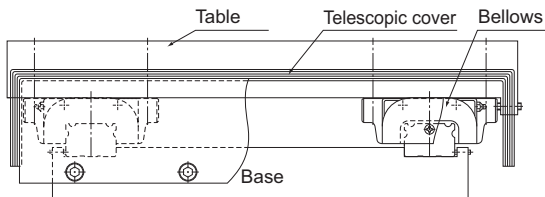

Fig. 1: Example of Mounting the Bellows

## Options

## Dedicated Bellows

## Dedicated Bellows JHRW for Model HRW

The table below shows the dimensions of dedicated bellows JHRW for model HRW. Specify the corresponding model number of the desired bellows from the table.

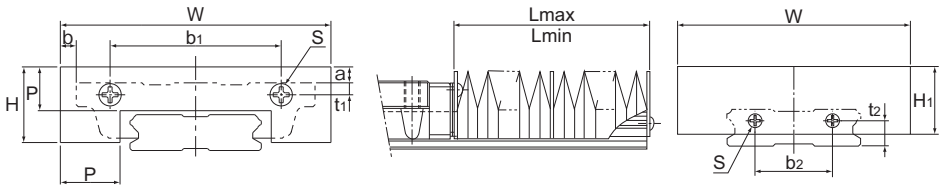

Unit: mm

Model No.	Main dimensions											A ( $\frac{L_{max}}{L_{min}}$ )	Supported model numbers			
	W	H	H <sub>1</sub>	P	b <sub>1</sub>	t <sub>1</sub>	b <sub>2</sub>	t <sub>2</sub>	Mounting bolt S	a	b					
											Model CA			Model CR		
JHRW	17	68	22	23	15	43	3	18	6	*M3×6ℓ	8	4	9	5	HRW	
	21	75	25	26	17	48	3	22	7	M3×6ℓ	8	3.5	10.5	6		21
	27	85	33.5	33.5	20	48	3	20	10	M3×6ℓ	10	2.5	11.5	7		27
	35	120	35	35	20	75	3.5	40	13	M3×6ℓ	6	0	10	7		35
	50	164	42	42	20	100	9	50	16	M4×8ℓ	-3	1	17	7		50

Note1) For model JHRW17's location marked with "\*", mounting bolts are used only on the LM rail side while the LM block side uses M2.5 x 8 (nominal) tapping screws.

Note2) Please contact THK if you will be using the dedicated bellows in anything other than a horizontal orientation (i.e., vertical, wall-mounted, or inverted), or if you require heat-resistant specifications.

Note3) For lubrication when using the dedicated bellows, contact THK.

Note4) When using the dedicated bellows, the LM block and LM rail need to be machined so that the bellows can be mounted. Be sure to indicate that the dedicated bellows is required when ordering the LM Guide.

## Model number coding

## JHRW21 - 60/360

Model number of bellows for HRW21

Dimensions of the bellows (length when compressed / length when extended)

Note) The length of the bellows is calculated as follows.

$$L_{min} = \frac{S}{(A-1)} \quad S: \text{Stroke length (mm)}$$

$$L_{max} = L_{min} \cdot A \quad A: \text{Extension rate}$$

## Dedicated Bellows J for Model NSR-TBC

The table below shows the dimensions of dedicated bellows J for model NSR-TBC. Specify the corresponding model number of the desired bellows from the table.

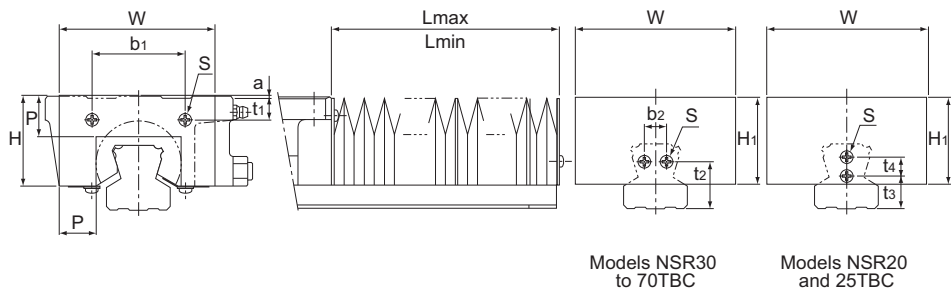

Unit: mm

Model No.	Main dimensions													A ( $\frac{L_{max}}{L_{min}}$ )	Supported model numbers	
	W	H	H <sub>1</sub>	P	b <sub>1</sub>	t <sub>1</sub>	b <sub>2</sub>	t <sub>2</sub>	t <sub>3</sub>	t <sub>4</sub>	Mounting bolt S	a				
J	20	65	39	43	20	26	8	—	—	9	8	M4×8ℓ	8	7	NSR	20TBC
	25	75	43	45	20	40	11	—	—	12	8	M4×8ℓ	3	7		25TBC
	30	85	46	46	20	50	12	12	25	—	—	M4×8ℓ	—	7		30TBC
	40	115	59	59	25	60	13	16	32	—	—	M5×10ℓ	—	9		40TBC
	50	115	66	66	25	75	11	20	32	—	—	M5×10ℓ	—	9		50TBC
	70	124	84	78	25	96	16	36	40	—	—	M6×12ℓ	—	9		70TBC

Note1) Please contact THK if you will be using the dedicated bellows in anything other than a horizontal orientation (i.e., vertical, wall-mounted, or inverted), or if you require heat-resistant specifications.

Note2) When using the dedicated bellows, the LM block and LM rail need to be machined so that the bellows can be mounted. Be sure to indicate that the dedicated bellows is required when ordering the LM Guide.

### Model number coding

## J50 - 60/540

Model number of bellows for NSR50TBC

Dimensions of the bellows (length when compressed / length when extended)

Note) The length of the bellows is calculated as follows.

$$L_{min} = \frac{S}{(A-1)} \quad S: \text{Stroke length (mm)}$$

$$L_{max} = L_{min} \cdot A \quad A: \text{Extension rate}$$

## Dedicated Bellows JSRG for Model SRG

The table below shows the dimensions of dedicated bellows JSRG for model SRG. Specify the corresponding model number of the desired bellows from the table.

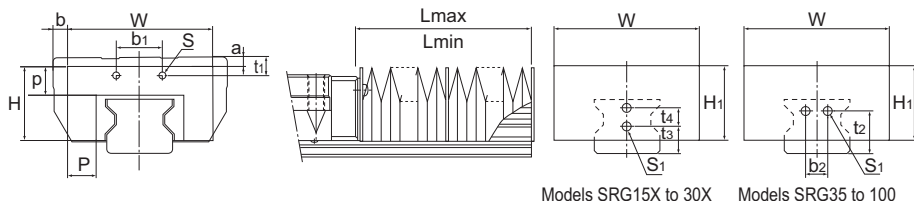

Unit: mm

Model No.	Main dimensions																Supported model numbers					
	W	H	H <sub>1</sub>	P	p	b <sub>1</sub>	t <sub>1</sub>		b <sub>2</sub>	t <sub>2</sub>	t <sub>3</sub>	t <sub>4</sub>	Screw size S	Mounting bolt S <sub>1</sub>	a			b		A L <sub>max</sub> L <sub>min</sub>		
							A/C	R/V							A/C	R/V		A/C	R/V			
JSRG	15	55	27	27	14.2	12.7	28	10.3	10.3	—	—	10.6	—	M2	M4	-7	-7	4	10.5	5	SRG	15X
	20	66	32	32	17	15	38.5	9.6	9.6	—	—	7.4	8	M2	M3	-6.6	-6.6	1.5	11	6		20X
	25	78	38	38	23	18	27.6	3.9	7.9	—	—	10	8	M2	M3×6ℓ	-6.5	-2.5	4	15	6		25X
	30	84	42	42	22	19	37.4	10.4	13.4	—	—	11	10	M3	M4×8ℓ	-5	-2	3	12	7		30X
	35	88	42	42	22	15	35	5	12	13	23	—	—	M3	M4×4ℓ	0	7	6	-9	5		35
	45	100	51	51	20	20	32	7	17	15	29	—	—	M3	M5×4ℓ	0	10	10	-7	7		45
	55	108	57	57	20	20	36	10	20	25	35	—	—	M3	M5×4ℓ	3	13	16	-4	7		55
	65	132	75.5	75.5	28.5	25	46	9	9	28	42	—	—	M4	M6×5ℓ	3	3	19	-3	9		65
	85	168	91	91	35.5	30	120	15	—	30	55	—	—	M6	M6×8ℓ	3	—	23.5	—	9		85
	100	198	100	100	43	33	152	13.3	—	36	60	—	—	M6	M6×8ℓ	4	—	26	—	9		100

Note1) Please contact THK if you will be using the dedicated bellows in anything other than a horizontal orientation (i.e., vertical, wall-mounted, or inverted), or if you require heat-resistant specifications.

Note2) When using the bellows, lubrication is possible through methods such as a side nipple.

Note3) When using the dedicated bellows, the LM block and LM rail need to be machined so that the bellows can be mounted. Be sure to indicate that the dedicated bellows is required when ordering the LM Guide.

Note4) In case of oil lubrication, be sure to let THK know the mounting orientation and the exact position in each LM block where the piping joint should be attached.

For the mounting orientation and the lubrication, see **A1-12** and **A24-2**, respectively.

## Model number coding

## JSRG35 - 60/420

Model number of bellows for SRG35

Dimensions of the bellows (length when compressed / length when extended)

Note) The length of the bellows is calculated as follows.

$$L_{\min} = \frac{S}{(A-1)} \quad S: \text{Stroke length (mm)}$$

$$L_{\max} = L_{\min} \cdot A \quad A: \text{Extension rate}$$

## Dedicated Bellows JSRW for Model SRW

The table below shows the dimensions of dedicated bellows JSRW for model SRW. Specify the corresponding model number of the desired bellows from the table.

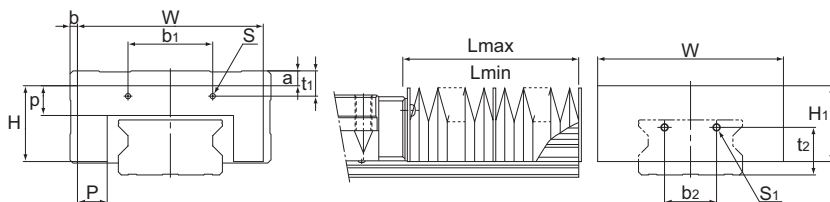

Unit: mm

Model No.	Main dimensions														A ( $\frac{L_{max}}{L_{min}}$ )	Supported model numbers	
	W	H	H <sub>1</sub>	P	p	b <sub>1</sub>	t <sub>1</sub>	b <sub>2</sub>	t <sub>2</sub>	Screw size S	Mounting bolt S <sub>1</sub>	a	b				
JSRW	70	125	51	51	20	20	57	17	35	32	M3	M5×4L	10	5	7	SRW	70
	85	138	57	57	20	20	68	20	42	36	M3	M5×4L	13	13.5	7		85
	100	169	75.5	75.5	28.5	25	83	19	50	46	M4	M6×5L	13	15.5	9		100
	130	220	96	96	36.5	35	165	35	60	55	M6	M6×8L	18	20	9		130
	150	260	114	114	49	47	200	43.3	70	60	M6	M6×8L	20	20	9		150

Note1) When using the bellows, lubrication is possible through methods such as a side nipple.

Note2) Please contact THK if you will be using the dedicated bellows in anything other than a horizontal orientation (i.e., vertical, wall-mounted, or inverted), or if you require heat-resistant specifications.

### Model number coding

## JSRW70 - 60/420

Model number of bellows for SRW70 | Dimensions of the bellows (length when compressed / length when extended)

## Options

## Dedicated Bellows

## Dedicated Bellows JHRX for Model HRX

The table below shows the dimensions of dedicated bellows JHRX for model HRX. Specify the corresponding model number of the desired bellows from the table.

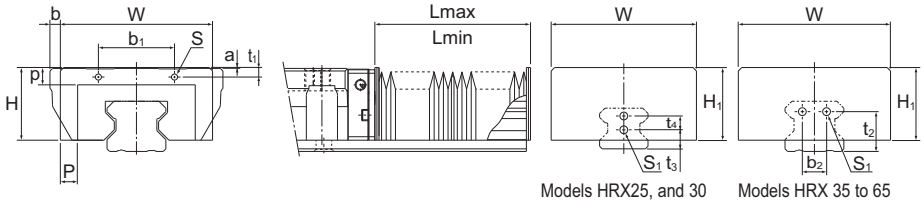

Models HRX25, and 30

Models HRX 35 to 65

Unit: mm

Model No.	Main dimensions																Supported model numbers					
	W	H	H <sub>1</sub>	P	p	b <sub>1</sub>	t <sub>1</sub>				Screw size S	Mounting bolt S <sub>1</sub>	a		b			A ( $\frac{L_{max}}{L_{min}}$ )				
							C	R	b <sub>2</sub>	t <sub>2</sub>			t <sub>3</sub>	t <sub>4</sub>	C	R			C	R		
JHRX	25	78	38	38	16	15	29	3.7	7.7	—	—	10	8	M2	M3	-7	-3	-4	-15	6	HRX	25
	30	84	42	42	13.5	15	40	4	7	—	—	11	8	M2	M3	-5	-2	3	-12	7		30
	35	88	42	42	10	10	44	5	12	14	23	—	—	M3	M4	-0.5	6.5	6	-9	5		35
	45	100	51	51	20	12	52	5.2	15.2	20	29	—	—	M3	M5	0.5	10.5	10	-7	7		45
	55	108	57	57	20	13	54	7.3	17.3	26	35	—	—	M3	M5	2	12	16	-4	7		55
	65	132	75.5	75.5	25	20	80	9	19	32	42	—	—	M4	M6	2.5	12.5	19	-3	9		65

Note1) Please contact THK if you will be using the dedicated bellows in anything other than a horizontal orientation (i.e., vertical, wall-mounted, or inverted), or if you require heat-resistant specifications.

Note2) When using the bellows, lubrication is possible through methods such as a side nipple.

Note3) When using the dedicated bellows, the LM block and LM rail need to be machined so that the bellows can be mounted. Be sure to indicate that the dedicated bellows is required when ordering the LM Guide.

## Model number coding

## JHRX25 - 60/360

Model number of bellows for HRX25

Dimensions of the bellows (length when compressed / length when extended)

Note) The length of the bellows is calculated as follows.

$$L_{min} = \frac{S}{(A-1)} \quad S: \text{Stroke length (mm)}$$

$$L_{max} = L_{min} \cdot A \quad A: \text{Extension rate}$$