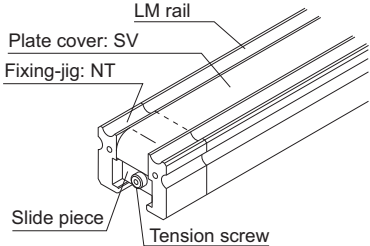
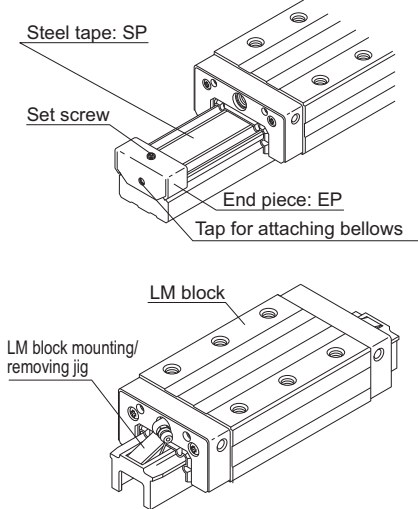

# Plate Cover SV and Steel Tape SP

● For the supported models, see the table of options by model number on [A1-504](#).

Item name	Schematic diagram/mounting location	Purpose/location of use
<p>Plate Cover SV</p>		<p>A plate cover is available as a means of essential contamination protection for LM Guide units intended for use in machine tools. By covering the LM rail mounting holes with ultra-thin stainless steel (SUS304), the plate cover SV drastically increases the effectiveness of the seal and prevents the penetration of coolant or cutting chips from the top face of the LM rail.</p> <p>For the mounting method, see <a href="#">A1-566</a>.</p> <p>Note) When mounting the plate cover, the LM rail needs to be machined. Indicate that the plate cover is required when ordering the LM Guide.</p>
<p>Steel Tape SP</p>		<p>Steel tape is available as a means of essential contamination protection for LM Guide units intended for use in machine tools. By covering the LM rail mounting holes with ultra-thin stainless steel (SUS304), the steel tape SP drastically increases the effectiveness of the seal and prevents the penetration of coolant or cutting chips from the top face of the LM rail. (When mounting the steel tape, end piece EP can be used as a means to secure the cover.)</p> <p>For the mounting method, see <a href="#">A1-567</a>.</p> <p>Note) When mounting the steel tape, the LM rail needs to be machined. Indicate that the steel tape is required when ordering the LM Guide.</p>

### Mounting Procedure for Plate Cover SV

- (1) Attach slide pieces to the plate cover.

Place the slide pieces on the plate cover with their chamfered sides facing outward, hold the plate cover with the slide pieces and the securing plates, and then secure them with countersunk screws.

- (2) Use an LM block mounting/removing jig to remove the LM block from the LM rail, and then mount the fixing-jigs onto the LM rail.  
 (3) Temporarily secure either slide piece.

Insert either slide piece into one of the fixing-jigs, then attach the slide piece to the LM rail's end face using the tension adjustment bolt and gently secure the bolt until the bolt head is inside the fixing-jig.

- (4) Temporarily secure the other slide piece.

Temporarily secure the other slide piece in the same manner as above.

- (5) Apply tension to the plate cover.

Apply tension to the plate cover by evenly securing the tension adjustment bolts on both ends of the LM rail. Make sure there is only a small difference between the H and H' dimensions in Fig. 5. If the difference is too large, one end may have insufficient interference.

- (6) Mount the LM block on the LM rail.

Identify the reference surface of the LM rail and the LM block, then insert the LM rail into the LM block using the LM block mounting/removing jig.

Note1) When removing or mounting the LM block, use much care not to let the balls fall out.

Note2) The plate cover is an ultra-thin stainless steel (SUS304) plate. When handling it, use much care not to bend it.

Note3) The plate cover is available for model NR/NRS 75.

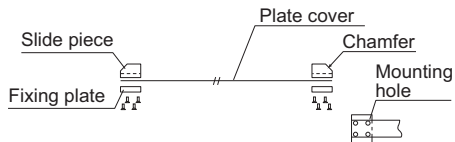

Fig. 1



Fig. 2

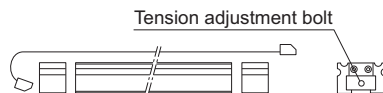

Fig. 3



Fig. 4



Fig. 5

### Mounting Procedure for Steel Tape SP

- (1) Use an LM block mounting/removing jig to remove the LM block from the LM rail.
- (2) Thoroughly degrease and clean the top face of the LM rail to which the steel tape is to be adhered. For degreasing, use an adequately volatile detergent (e.g., industrial alcohol).
- (3) Carefully adhere the steel tape from the end with care not to let it bend or sag, while gradually peeling the release paper from the steel tape.
- (4) Secure the steel tape to the rail by pressing it down and rubbing it. The adhesive strength increases with time. However, if you wish to remove the tape, it can be removed by pulling it upward from the end.
- (5) Mount the LM block onto the LM rail using the LM block mounting/removing jig.
- (6) Attach the end pieces on both ends of the LM rail and further secure the steel tape. When securing the end pieces, fasten only the set screw on the top face of each end piece.

(The tap on the end face of the end piece is used for mounting bellows.)

Note1) The set screw on the side face is used to lightly secure the bent steel tape. Be sure to stop fastening the screw as soon as it hits the end face, and do not force the screw further.

Note2) Since the steel tape is a thin steel plate, mishandling it may cause an accident such as cutting your finger. When handling it, take an effective safety measure such as wearing rubber gloves.

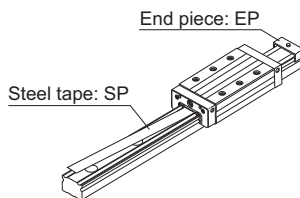

Fig. 6

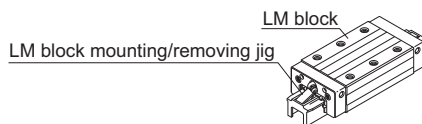

Fig. 7

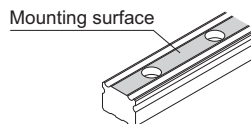

Fig. 8

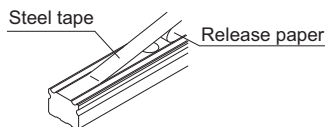

Fig. 9

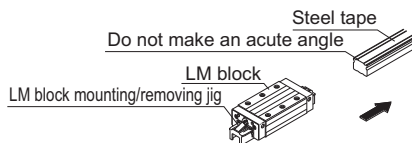

Fig. 10

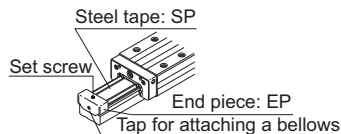

Fig. 11