

# KR

## LM Guide Actuator Model KR

### LM Guide + Ball Screw = Integral-structure Actuator

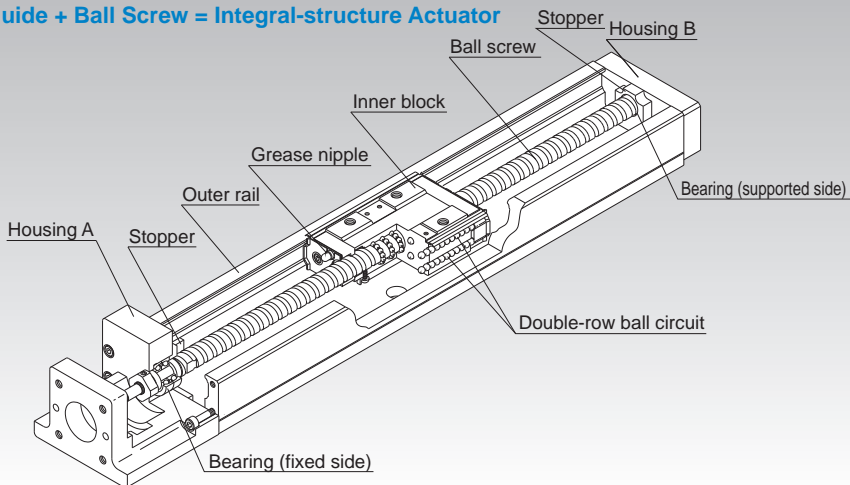

Fig.1 Structure of LM Guide Actuator Model KR

## Structure and Features

Because of its integral-structure inner block consisting of a highly rigid outer rail with a U-shaped cross section, LM Guide units on both side faces and a Ball Screw unit in the center, LM Guide Actuator model KR achieves a highly rigid and highly accurate actuator in a minimal space.

In addition, since the housings A and B also serve as support units and the inner block as a table, this model allows significant reduction of man-hours required for design and assembly, thus contributing to total cost cutting.

**[4-way Equal Load]**

Each row of balls is arranged at a contact angle of  $45^\circ$  so that the rated load on the inner block is uniform under loads applied to the inner block in the four directions (radial, reverse radial and lateral directions). As a result, model KR can be used in any mounting orientation.

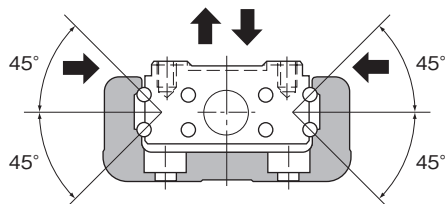

Fig.2 Load Capacity and Contact Angle of Model KR

**[High Rigidity]**

Use of an outer rail with a U-shaped cross section increases the rigidity against a moment and torsion.

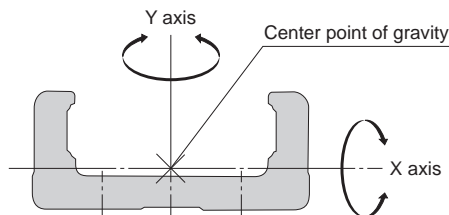

Fig.3 Cross Section of the Outer Rail

Table1 Cross-sectional Characteristics of the Outer rail Rail

Model No.	$I_x$ [mm <sup>4</sup> ]	$I_y$ [mm <sup>4</sup> ]	Mass[kg/m]
KR15	$9.08 \times 10^2$	$1.42 \times 10^4$	1.04
KR20	$6.1 \times 10^3$	$6.2 \times 10^4$	2.6
KR26	$1.7 \times 10^4$	$1.5 \times 10^5$	3.9
KR30H	$2.7 \times 10^4$	$2.8 \times 10^5$	5.0
KR33	$6.2 \times 10^4$	$3.8 \times 10^5$	6.6
KR45H	$8.4 \times 10^4$	$8.9 \times 10^5$	9.0
KR46	$2.4 \times 10^5$	$1.5 \times 10^6$	12.6
KR55	$2.2 \times 10^5$	$2.3 \times 10^6$	15.0
KR65	$4.6 \times 10^5$	$5.9 \times 10^6$	23.1

$I_x$ =geometrical moment of inertia around X axis

$I_y$ =geometrical moment of inertia around Y axis

**[High Accuracy]**

Since the linear guide section consists of 4 rows of circular-arc grooves that enable balls to smoothly move even under a preload, a highly rigid guide with no clearance is achieved. Additionally, variation in frictional resistance caused by load fluctuation is minimized, allowing the system to follow highly accurate feed.

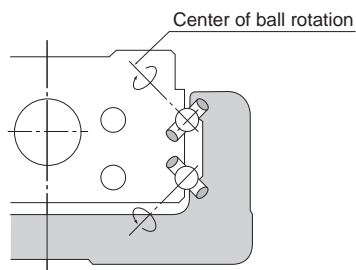

Fig.4 Contact Structure of Model KR

**[Space Saving]**

Use of a inner block integrating LM Guide units on both ends and a Ball Screw unit in the center makes model KR a highly rigid and highly accurate actuator in a minimal space.

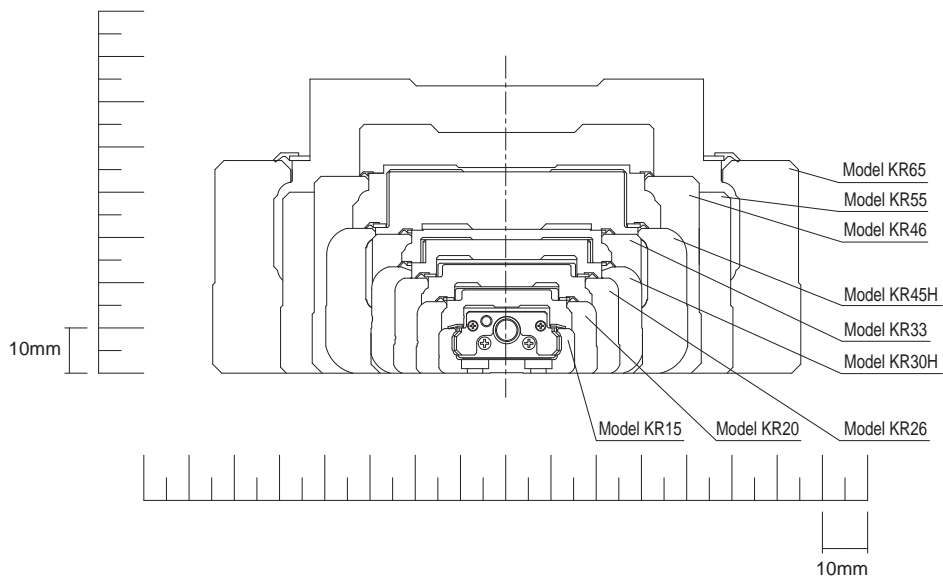

Fig.5 Cross Sectional Drawing

**[Seal]**

Model KR is equipped with end seals and side seals for dust prevention as standard.

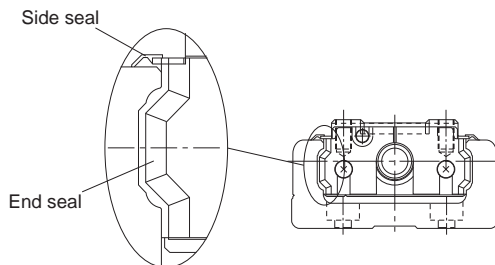

Table2 shows the rolling resistance and seal resistance per inner block (guide section).

Table2 Maximum Resistance Value Unit: N

Model No.	Rolling resistance value	Seal resistance value	Total
KR15	0.2	0.7	0.9
KR20	0.5	0.7	1.2
KR26	0.6	0.8	1.4
KR30H	1.5	2.0	3.5
KR33	1.5	1.9	3.4
KR45H	2.5	2.6	5.1
KR46	2.5	2.5	5
KR55	5.0	3.8	8.8
KR65	6.0	4.1	10.1

Note) The rolling resistance represents the value when a lubricant is not used.

---

## Types and Features

---

### Model KR-A (with a Single Long Type Block)

Representative model of KR.

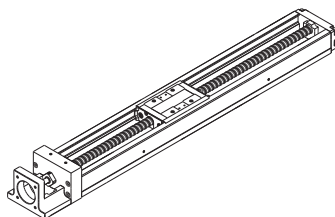

Model KR-A

---

### Model KR-B (with Two Long Type Blocks)

Equipped with two units of the inner block of model KR-A, this model achieves higher rigidity and higher load carrying capacity.

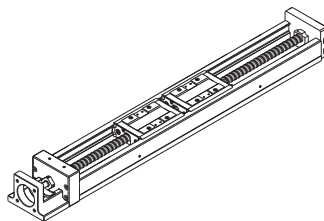

Model KR-B

---

### Model KR-C (with a Single Short Type Block)

This model has a shorter overall length of the inner block and a longer stroke than model KR-A.

(Supported models: model KR30H, 33, 45H, 46)

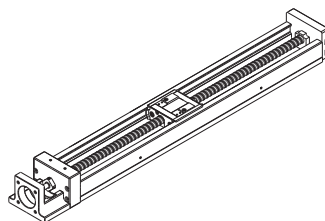

Model KR-C

---

### Model KR-D (with Two Short Type Blocks)

Equipped with two units of the inner block of model KR-C, this design allows a span between blocks that suits the equipment, thus to achieve high rigidity.

(Supported models: model KR30H, 33, 45H, 46)

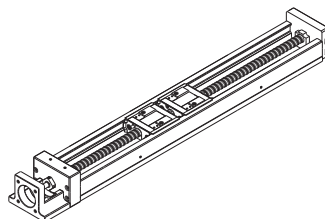

Model KR-D

## Load Ratings in All Directions and Static Permissible Moment

### [Load Rating]

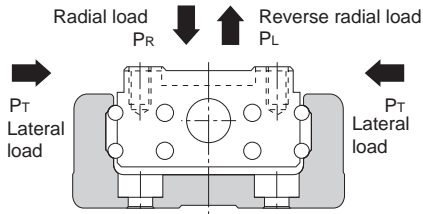

#### ● LM Guide Unit

Model KR is capable of receiving loads in four directions (radial, reverse radial and lateral directions). Its basic load ratings are equal in all four directions (radial, reverse radial and lateral directions), and their values are indicated in Table3 on **A2-90** and **A2-91**.

#### ● Ball Screw Unit

Since the inner block is incorporated with a ball screw nut, model KR is capable of receiving an axial load. The basic load rating value is indicated in Table3 on **A2-90** and **A2-91**.

#### ● Bearing Unit (Fixed Side)

Since housing A contains an angular bearing, model KR is capable of receiving an axial load. The basic load rating value is indicated in Table3 on **A2-90** and **A2-91**.

### [Equivalent Load (LM Guide Unit)]

The equivalent load when the LM Guide unit of model KR simultaneously receives loads in all directions is obtained from the following equation.

$$P_E = P_R (P_L) + P_T$$

$P_E$  : Equivalent load (N)

: Radial direction

: Reverse radial direction

: Lateral direction

$P_R$  : Radial load (N)

$P_L$  : Reverse radial load (N)

$P_T$  : Lateral load (N)

Table3 Load Rating of Model KR

Model No.			KR15		KR20		KR26		
			KR1501	KR1502	KR2001	KR2006	KR2602	KR2606	
LM guide unit	Basic dynamic load rating C (N)	Long type block	1930		3590		7240		
		Short type block	—		—		—		
	Basic static load rating C <sub>0</sub> (N)	Long type block	3450		6300		12150		
		Short type block	—		—		—		
	Radial clearance (mm)	Normal grade, high accuracy grade	-0.001 to +0.002		-0.003 to +0.002		-0.004 to +0.002		
		Precision grade	-0.005 to -0.002		-0.007 to -0.003		-0.01 to -0.004		
Ball screw unit	Basic dynamic load rating C <sub>a</sub> (N)	Normal grade, high accuracy grade	340	230	660	860	2350	1950	
		Precision grade	340	230	660	1060	2350	2390	
	Basic static load rating C <sub>0a</sub> (N)	Normal grade, high accuracy grade	660	410	1170	1450	4020	3510	
		Precision grade	660	410	1170	1600	4020	3900	
	Screw shaft diameter (mm)		5		6		8		
	Lead (mm)		1	2	1	6	2	6	
	Thread minor diameter (mm)		4.5		5.3	5.0	6.6	6.7	
	Ball center-to-center diameter (mm)		5.15		6.15	6.3	8.3	8.4	
Bearing unit (Fixed side)	Axial direction	Basic dynamic load rating C <sub>a</sub> (N)	590		1000		1380		
		Static permissible load P <sub>0a</sub> (N)	290		1240		1760		

Note1) The load ratings in the LM Guide unit each indicate the load rating per inner block.

Note2) The Ball Screw of precision grade (grade P) for models KR30H, KR33, KR45H10 and KR4610 is incorporated with spacer balls in the proportion of one to one.

Note3) The Ball Screw of precision grade (grade P) for models KR45H20, KR4620, KR55 and KR65 is incorporated with spacer balls in the proportion of two to one.

	KR30H		KR33		KR45H		KR46		KR55	KR65
	KR30H06	KR30H10	KR3306	KR3310	KR45H10	KR45H20	KR4610	KR4620		
	11600		11600		23300		27400		38100	50900
	4900		4900		11900		14000		—	—
	20200		20200		39200		45500		61900	80900
	10000		10000		19600		22700		—	—
	-0.004 to +0.002		-0.004 to +0.002		-0.006 to +0.003		-0.006 to +0.003		-0.007 to +0.004	-0.008 to +0.004
	-0.012 to -0.004		-0.012 to -0.004		-0.016 to -0.006		-0.016 to -0.006		-0.019 to -0.007	-0.022 to -0.008
	2840	1760	2840	1760	3140	3040	3140	3040	3620	5680
	2250	1370	2250	1370	2940	3430	2940	3430	3980	5950
	4900	2840	4900	2840	6760	7150	6760	7150	9290	14500
	2740	1570	2740	1570	3720	5290	3720	5290	6850	10700
	10		10		15		15		20	25
	6	10	6	10	10	20	10	20	20	25
	7.8		7.8		12.5		12.5		17.5	22
	10.5		10.5		15.75		15.75		20.75	26
	1790		1790		6660		6660		7600	13700
	2590		2590		3240		3240		3990	5830



### [Static Permissible Moment (LM Guide Unit)]

The Inner block is capable of receiving moment loads in all three (3) directions.

Table 4 on **A2-93** shows static permissible moments in the  $M_A$ ,  $M_B$  and  $M_C$  directions.

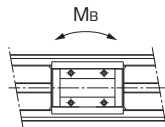
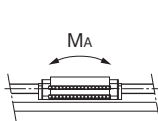
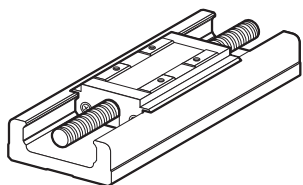

With a single long type block (Model KR-A)

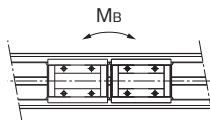
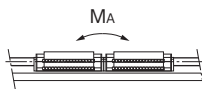
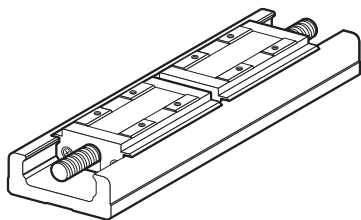

With double long type blocks (Model KR-B)

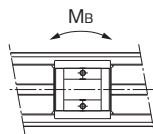
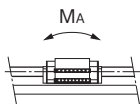
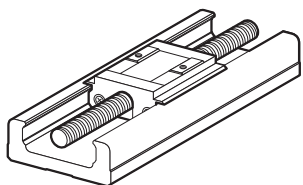

With a single short type block (Model KR-C)

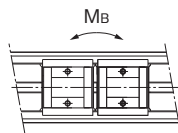
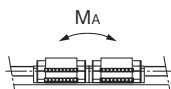
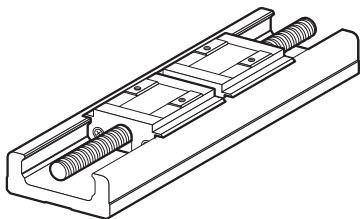

With double short type blocks (Model KR-D)

Table4 Static Permissible Moments of Model KR

Unit: N·m

Model No.	Static permissible moment		
	M <sub>A</sub>	M <sub>B</sub>	M <sub>C</sub>
KR15-A	12.1 (5)	12.1 (5)	38 (5)
KR15-B	70.3 (16)	70.3 (22)	76 (18)
KR20-A	31 (9)	31 (8)	83 (13)
KR20-B	176 (39)	176 (32)	165 (27)
KR26-A	84 (31)	84 (22)	208 (30)
KR26-B	480 (154)	480 (78)	416 (60)
KR30H-A	166 (32)	166 (40)	428 (46)
KR30H-B	908 (256)	908 (155)	857 (103)
KR30H-C	44 (10)	44 (14)	214 (20)
KR30H-D	319 (84)	319 (55)	427 (51)
KR33-A	166 (53)	166 (40)	428 (53)
KR33-B	908 (271)	908 (158)	857 (107)
KR33-C	44 (7)	44 (14)	214 (26)
KR33-D	319 (90)	319 (56)	427 (53)
KR45H-A	486 (34)	486 (95)	925 (31)
KR45H-B	2732 (159)	2732 (355)	1850 (63)
KR45H-C	130 (16)	130 (32)	463 (15)
KR45H-D	994 (52)	994 (124)	925 (31)
KR46-A	547 (34)	547 (98)	1400 (34)
KR46-B	2940 (165)	2940 (364)	2800 (69)
KR46-C	149 (18)	149 (34)	700 (17)
KR46-D	1010 (54)	1010 (129)	1400 (34)
KR55-A	870 (169)	870 (212)	2280 (169)
KR55-B	4890 (863)	4890 (831)	4570 (338)
KR65-A	1300 (326)	1300 (448)	3920 (326)
KR65-B	7230 (1349)	7230 (1512)	7840 (653)

Note1) Symbols A, B, C or D in the end of each model number indicates the inner block size and the number of inner blocks used.

A: With a single long type block

B: With double long type blocks

C: With a single short type block

D: With double short type blocks

Note2) The values for models KR-B/D indicate the values when double inner blocks are used in close contact with each other.

Note3) Static permissible moment is the maximum moment that can be permitted while the product is stationary.

Note4) Values in parentheses are with a cover or bellows.

## Maximum Speeds with Different Strokes

Table5 Maximum speed

Model No.	Ball Screw lead (mm)	Stroke <sup>*</sup> (mm)		Outer rail length (mm)	Maximum speed (mm/s)					
					Precision grade	High accuracy grade	Normal grade	Precision grade	High accuracy grade	Normal grade
		Long type block	Short type block		Long type block			Short type block		
KR15	01	25	—	75	100	100	—			
		50	—	100	100	100	—			
		75	—	125	100	100	—			
		100	—	150	100	100	—			
		125	—	175	100	100	—			
	02	150	—	200	100	100	—			
		25	—	75	200	200	—			
		50	—	100	200	200	—			
		75	—	125	200	200	—			
		100	—	150	200	200	—			
KR20	01	125	—	175	200	200	—			
		150	—	200	200	200	—			
		30	—	100	100	100	—			
	06	80	—	150	100	100	—			
		130	—	200	100	100	—			
KR26	02	30	—	100	600	600	—			
		80	—	150	600	600	—			
		130	—	200	600	600	—			
	06	60	—	150	200	200	—			
		110	—	200	200	200	—			
		160	—	250	200	200	—			
		210	—	300	200	200	—			
KR30H	06	60	—	150	600	590	—			
		110	—	200	600	590	—			
		160	—	250	600	590	—			
		210	—	300	600	590	—			
		50	70	150	600	470	600	470		
	10	100	120	200	600	470	600	470		
		200	220	300	600	470	600	470		
		300	320	400	600	470	600	470		
		400	420	500	590	470	530	470		
		500	520	600	390	390	360	360		
KR33	06	50	70	150	1000	790	1000	790		
		100	120	200	1000	790	1000	790		
		200	220	300	1000	790	1000	790		
		300	320	400	1000	790	1000	790		
		400	420	500	980	790	880	790		
		500	520	600	650	650	600	600		
	10	50	75	150	600	470	600	470		
		100	125	200	600	470	600	470		
		200	225	300	600	470	600	470		
		300	325	400	600	470	600	470		
KR33	06	400	425	500	590	470	530	470		
		500	525	600	390	390	360	360		
		600	625	700	280	280	260	260		
		50	75	150	1000	790	1000	790		
		100	125	200	1000	790	1000	790		
		200	225	300	1000	790	1000	790		
	10	300	325	400	1000	790	1000	790		
		400	425	500	980	790	880	790		
		500	525	600	650	650	600	600		
		600	625	700	470	470	430	430		

Model No.	Ball Screw lead (mm)	Stroke* (mm)		Outer rail length (mm)	Maximum speed (mm/s)					
					Precision grade	High accuracy grade	Normal grade	Precision grade	High accuracy grade	Normal grade
		Long type block	Short type block		Long type block			Short type block		
KR45H	10	200	230	340	740	520	740	520	740	520
		300	330	440	740	520	740	520	740	520
		400	430	540	740	520	740	520	740	520
		500	530	640	740	520	740	520	740	520
		600	630	740	730	520	640	520	640	520
		700	730	840	—	520	—	490	—	490
		800	830	940	—	430	—	380	—	380
		200	230	340	1480	1050	1480	1050	1480	1050
	300	330	440	1480	1050	1480	1050	1480	1050	
	400	430	540	1480	1050	1480	1050	1480	1050	
	500	530	640	1480	1050	1480	1050	1480	1050	
	600	630	740	1430	1050	1280	1050	1280	1050	
	700	730	840	—	1050	—	980	—	980	
	800	830	940	—	840	—	770	—	770	
KR46	10	190	220	340	740	520	740	520	740	520
		290	320	440	740	520	740	520	740	520
		390	420	540	740	520	740	520	740	520
		490	520	640	740	520	740	520	740	520
		590	620	740	730	520	650	520	650	520
		690	720	840	—	520	—	490	—	490
		790	820	940	—	430	—	390	—	390
		190	220	340	1480	1050	1480	1050	1480	1050
	290	320	440	1480	1050	1480	1050	1480	1050	
	390	420	540	1480	1050	1480	1050	1480	1050	
	490	520	640	1480	1050	1480	1050	1480	1050	
	590	620	740	1440	1050	1300	1050	1300	1050	
	690	720	840	—	1050	—	990	—	990	
	790	820	940	—	850	—	780	—	780	
KR55	20	800	—	980	1120	800	—	—	—	
		900	—	1080	900	800	—	—	—	
		1000	—	1180	740	740	—	—	—	
		1100	—	1280	—	620	—	—	—	
		1200	—	1380	—	530	—	—	—	
KR65	25	790	—	980	1120	800	—	—	—	
		990	—	1180	1120	800	—	—	—	
		1190	—	1380	840	800	—	—	—	
		1490	—	1680	—	550	—	—	—	

\*Indicates a stroke when one inner block is incorporated.

Note1) The maximum speed is restricted by the permissible rotation speed of the ball screw, the permissible speed of the guide or 6,000 min<sup>-1</sup> of motor speed.

Note2) If you are considering using this product at the maximum travel speed of Table5 or faster, contact THK.

## Lubrication

Table6 shows standard greases used in model KR and grease nipple types.

Table6 Types of standard grease and grease nipples used

Model No.	Standard grease	Grease nipple used
KR15	THK AFF Grease	—
KR20	THK AFA Grease	PB107
KR26	THK AFA Grease	PB107
KR30H	THK AFB-LF Grease	PB107
KR33	THK AFB-LF Grease	PB107
KR45H	THK AFB-LF Grease	A-M6F
KR46	THK AFB-LF Grease	A-M6F
KR55	THK AFB-LF Grease	A-M6F
KR65	THK AFB-LF Grease	A-M6F

## Static Safety Factor

LM Guide Actuator Model KR consists of an LM Guide, a Ball Screw and a support bearing. The static safety factor and the service life of each component can be obtained from the basic load rating indicated in "Rated load of model KR" (see Table3 on **A2-90**).

### [Calculating the Static Safety Factor]

#### ● LM Guide Unit

To calculate a load applied to the LM Guide of model KR, the average load required for calculating the service life and the maximum load needed for calculating the static safety factor must be obtained first. In particular, if the system starts and stops frequently, or if a large moment caused by an overhung load is applied to the system, it may receive an unexpectedly large load.

When selecting a model number, make sure that the desired model is capable of receiving the required maximum load (whether stationary or in motion).

$$f_s = \frac{C_0}{P_{\max}}$$

$f_s$  : Static safety factor

$C_0$  : Basic static load rating (N)

$P_{\max}$  : Maximum applied load (N)

\*The basic static load rating is a static load with a constant direction and magnitude whereby the sum of the permanent deformation of the rolling element and that of the raceway on the contact area under the maximum stress is 0.0001 times the rolling element diameter.

#### ● Ball Screw Unit/Bearing Unit(Fixed Side)

If an unexpected external force is applied in the axial direction as a result of an inertia caused by an impact or start and stop while model KR is stationary or operating, it is necessary to take into account the static safety factor.

$$f_s = \frac{C_{0a}}{F_{\max}}$$

$f_s$  : Static safety factor

$C_{0a}$  : Basic static load rating (N)

$F_{\max}$  : Maximum applied load (N)

### [Standard Values for the Static Safety Factor ( $f_s$ )]

Machine type	Load conditions	Minimum Static Safety Factor ( $f_s$ )
General industrial machinery	Without vibration or impact	1.0 to 3.5
	With vibration or impact	2.0 to 5.0

\*The standard value of the static safety factor may vary depending on the load conditions as well as environment, lubrication status, mounting accuracy, and/or rigidity.

## Service Life

### [LM Guide Unit]

#### ● Nominal Life

#### ■ Calculating the Nominal Life

The nominal life ( $L_{10}$ ) of an LM Guide with balls is obtained from the following formula using the basic dynamic load rating (C), which is based on a reference distance of 50 km, and the calculated load acting on the LM Guide ( $P_c$ ).

- LM Guide with balls (Using a basic dynamic load rating based on a nominal life of 50 km)

$$L_{10} = \left( \frac{C}{P_c} \right)^3 \times 50 \quad \dots\dots\dots (1)$$

$L_{10}$	:	Nominal life	(km)
C	:	Basic dynamic load rating	(N)
$P_c$	:	Calculated load	(N)

\*This nominal life formula may not apply if the length of the stroke is less than or equal to twice the length of the LM block.

When comparing the nominal life ( $L_{10}$ ), you must take into account whether the basic dynamic load rating was defined based on 50 km or 100 km. Convert the basic dynamic load rating based on ISO 14728-1 as necessary.

ISO-regulated basic dynamic load rating conversion formula:

- LM Guide with balls

$$C_{100} = \frac{C_{50}}{1.26}$$

$C_{50}$	:	Basic dynamic load rating based on a nominal life of 50 km
$C_{100}$	:	Basic dynamic load rating based on a nominal life of 100 km

#### ■ Calculating the Modified Nominal Life

During use, an LM Guide may be subjected to vibrations and shocks as well as fluctuating loads, which are difficult to detect. In addition, having LM blocks arranged directly behind one another will have a decisive impact on the service life. Taking these factors into account, the modified nominal life ( $L_{10m}$ ) can be calculated according to the following formula (2).

- Modified factor  $\alpha$

$$\alpha = \frac{f_c}{f_w}$$

$\alpha$	:	Modified factor
$f_c$	:	Contact factor (see Table7 on <b>A2-101</b> )
$f_w$	:	Load factor (see Table8 on <b>A2-101</b> )

- Modified nominal life  $L_{10m}$

- LM Guide with balls

$$L_{10m} = \left( \alpha \times \frac{C}{P_c} \right)^3 \times 50 \quad \dots\dots\dots (2)$$

$L_{10m}$	:	Modified nominal life	(km)
C	:	Basic dynamic load rating	(N)
$P_c$	:	Calculated load	(N)

- If a moment is applied to model KR-A/C or model KR-B/D using two inner blocks in close contact with each other, calculate the equivalent load by multiplying the applied moment by the equivalent factor indicated in Table9 on **A2-101**.

$$P_m = K \cdot M$$

- $P_m$  : Equivalent load (per inner block) (N)  
 $K$  : Equivalent moment factor (see Table9 on **A2-101**)  
 $M$  : Applied moment (N•mm)  
 (If planning to use the product with a wide inner block span, contact THK.)

- If moment  $M_c$  is applied to model KR-B/D

$$P_m = \frac{K_c \cdot M_c}{2}$$

- If a radial load ( $P$ ) and a moment are simultaneously applied to model KR

$$P_E = P_m + P$$

- $P_E$  : Total equivalent radial load (N)  
 Perform a nominal life calculation using the above data.

### ● Service Life Time

When the nominal life ( $L_{10}$ ) has been obtained, the service life time is obtained using the following equation (if the stroke length and the number of reciprocations per minute are constant).

$$L_h = \frac{L_{10} \times 10^6}{2 \cdot \ell_s \cdot n_1 \times 60}$$

- $L_h$  : Service life time (h)  
 $\ell_s$  : Stroke length (mm)  
 $n_1$  : Number of reciprocations per minute ( $\text{min}^{-1}$ )



## [Ball Screw Unit/Bearing Unit(Fixed Side)]

### ● Nominal Life

#### ■ Calculating the Nominal Life

The nominal life ( $L_{10}$ ) of an LM system is obtained from the following formula using the basic dynamic load rating (C) and the load acting on the ball screw in the axial direction ( $F_a$ ).

$$L_{10} = \left( \frac{C_a}{F_a} \right)^3 \times 10^6 \dots\dots\dots(1)$$

$L_{10}$	: Nominal life	(rev.)
$C_a$	: Basic dynamic load rating	(N)
$F_a$	: Axial load	(N)

#### ■ Calculating the Modified Nominal Life

During use, a ball screw may be subjected to vibrations and shocks as well as fluctuating loads, which are difficult to detect. Taking these factors into account, the modified nominal life ( $L_{10m}$ ) can be calculated according to the following formula (2).

- Modified factor  $\alpha$

$$\alpha = \frac{1}{f_w}$$

$\alpha$	: Modified factor	
$f_w$	: Load factor	(see Table8 on <b>A2-101</b> )

- Modified nominal life  $L_{10m}$

$$L_{10m} = \left( \alpha \times \frac{C_a}{F_a} \right)^3 \times 10^6 \dots\dots\dots(2)$$

$L_{10m}$	: Modified nominal life	(rev.)
$\alpha$	: Modified factor	
$C_a$	: Basic dynamic load rating	(N)
$F_a$	: Axial load	(N)

### ● Service Life Time

When the nominal life ( $L_{10}$ ) has been obtained, the service life time is obtained using the following equation (if the stroke length and the number of reciprocations per minute are constant).

$$L_h = \frac{L_{10} \cdot \ell}{2 \cdot \ell_s \cdot n_1 \times 60}$$

$L_h$	: Service life time	(h)
$\ell_s$	: Stroke length	(mm)
$n_1$	: Number of reciprocations per minute	(min <sup>-1</sup> )
$\ell$	: Ball Screw lead	(mm)

### ■f<sub>c</sub>: Contact Factor

If two inner blocks are used in close contact with each other with model KR-B/D, multiply the basic load rating by the corresponding contact factor indicated in Table7.

Table7 Contact Factor (f<sub>c</sub>)

Inner block types	Contact factor f <sub>c</sub>
Model KR-B Model KR-D	0.81

### ■f<sub>w</sub>: Load Factor

Table8 shows load factors.

Table8 Load Factor (f<sub>w</sub>)

Vibrations/impact	Speed(V)	f <sub>w</sub>
Faint	Very low V ≤ 0.25m/s	1 to 1.2
Weak	Slow 0.25 < V ≤ 1m/s	1.2 to 1.5
Medium	Medium 1 < V ≤ 2m/s	1.5 to 2
Strong	High V > 2m/s	2 to 3.5

### ■K: Moment Equivalent Factor (LM Guide Unit)

When model KR travels under a moment, the distribution of load applied to the LM Guide is locally large (see **A 1-40**). In such cases, calculate the load by multiplying the moment value by the corresponding moment equivalent factor indicated in Table9.

Symbols K<sub>A</sub>, K<sub>B</sub> and K<sub>C</sub> indicate the moment equivalent loads in the M<sub>A</sub>, M<sub>B</sub> and M<sub>C</sub> directions, respectively.

Table9 Equivalent moment factor(K)

Model No.	K <sub>A</sub>	K <sub>B</sub>	K <sub>C</sub>
KR15-A	3.2 × 10 <sup>-1</sup>	3.2 × 10 <sup>-1</sup>	9.09 × 10 <sup>-2</sup>
KR15-B	5.96 × 10 <sup>-2</sup>	5.96 × 10 <sup>-2</sup>	9.09 × 10 <sup>-2</sup>
KR20-A	2.4 × 10 <sup>-1</sup>	2.4 × 10 <sup>-1</sup>	7.69 × 10 <sup>-2</sup>
KR20-B	4.26 × 10 <sup>-2</sup>	4.26 × 10 <sup>-2</sup>	7.69 × 10 <sup>-2</sup>
KR26-A	1.73 × 10 <sup>-1</sup>	1.73 × 10 <sup>-1</sup>	5.88 × 10 <sup>-2</sup>
KR26-B	3.06 × 10 <sup>-2</sup>	3.06 × 10 <sup>-2</sup>	5.88 × 10 <sup>-2</sup>
KR30H-A	1.51 × 10 <sup>-1</sup>	1.51 × 10 <sup>-1</sup>	4.78 × 10 <sup>-2</sup>
KR30H-B	2.76 × 10 <sup>-2</sup>	2.76 × 10 <sup>-2</sup>	4.78 × 10 <sup>-2</sup>
KR30H-C	2.77 × 10 <sup>-1</sup>	2.77 × 10 <sup>-1</sup>	4.78 × 10 <sup>-2</sup>
KR30H-D	3.99 × 10 <sup>-2</sup>	3.99 × 10 <sup>-2</sup>	4.78 × 10 <sup>-2</sup>
KR33-A	1.51 × 10 <sup>-1</sup>	1.51 × 10 <sup>-1</sup>	4.93 × 10 <sup>-2</sup>
KR33-B	2.57 × 10 <sup>-2</sup>	2.57 × 10 <sup>-2</sup>	4.93 × 10 <sup>-2</sup>
KR33-C	2.77 × 10 <sup>-1</sup>	2.77 × 10 <sup>-1</sup>	4.93 × 10 <sup>-2</sup>
KR33-D	3.55 × 10 <sup>-2</sup>	3.55 × 10 <sup>-2</sup>	4.93 × 10 <sup>-2</sup>
KR45H-A	9.83 × 10 <sup>-2</sup>	9.83 × 10 <sup>-2</sup>	3.45 × 10 <sup>-2</sup>
KR45H-B	1.87 × 10 <sup>-2</sup>	1.87 × 10 <sup>-2</sup>	3.45 × 10 <sup>-2</sup>
KR45H-C	1.83 × 10 <sup>-1</sup>	1.83 × 10 <sup>-1</sup>	3.45 × 10 <sup>-2</sup>
KR45H-D	2.81 × 10 <sup>-2</sup>	2.81 × 10 <sup>-2</sup>	3.45 × 10 <sup>-2</sup>
KR46-A	1.01 × 10 <sup>-1</sup>	1.01 × 10 <sup>-1</sup>	3.38 × 10 <sup>-2</sup>
KR46-B	1.78 × 10 <sup>-2</sup>	1.78 × 10 <sup>-2</sup>	3.38 × 10 <sup>-2</sup>
KR46-C	1.85 × 10 <sup>-1</sup>	1.85 × 10 <sup>-1</sup>	3.38 × 10 <sup>-2</sup>
KR46-D	2.5 × 10 <sup>-2</sup>	2.5 × 10 <sup>-2</sup>	3.38 × 10 <sup>-2</sup>
KR55-A	8.63 × 10 <sup>-2</sup>	8.63 × 10 <sup>-2</sup>	2.83 × 10 <sup>-2</sup>
KR55-B	1.53 × 10 <sup>-2</sup>	1.53 × 10 <sup>-2</sup>	2.83 × 10 <sup>-2</sup>
KR65-A	7.55 × 10 <sup>-2</sup>	7.55 × 10 <sup>-2</sup>	2.14 × 10 <sup>-2</sup>
KR65-B	1.35 × 10 <sup>-2</sup>	1.35 × 10 <sup>-2</sup>	2.14 × 10 <sup>-2</sup>

Note) The values for models KR-B/D indicate the values when double inner blocks are used in close contact with each other.

## Accuracy Standards

The accuracy standard of model KR is defined in positioning repeatability, positioning accuracy, running parallelism (vertical direction) and backlash.

### [Positioning Repeatability]

Command the position to a given arbitrary point. Measure the position and repeat seven times from the same direction. Record the difference between the largest and smallest values. Conduct the same test at three points: the middle of the stroke, and at both the approximate maximum and minimum positions of travel. Express the maximum difference value of the three measurements divided by 2 with a “±” sign.

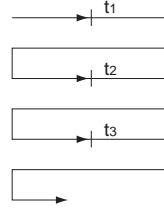

Fig.6 Positioning Repeatability

### [Positioning Accuracy]

Using the maximum stroke as the reference length, express the maximum error between the actual distance traveled from the reference point and the command value in an absolute value as positioning accuracy.

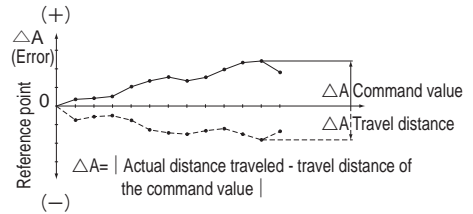

Fig.7 Positioning Accuracy

### [Running of Parallelism (Vertical direction)]

Place a straightedge on the surface table where model KR is mounted, measure almost throughout the travel distance of the inner block using a test indicator. Use the maximum difference among the readings within the travel distance as the running parallelism measurement.

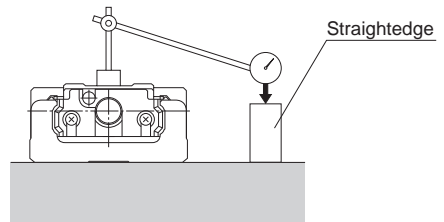

Fig.8 Running of Parallelism

### [Backlash]

Feed and slightly move the inner block and read the measurement on the test indicator as the reference value. Subsequently, apply a load to the inner block from the same direction (table feed direction), and then release the inner block from the load. Use the difference between the reference value and the return as the backlash measurement.

Perform this measurement in the center and near both ends, and use the maximum value as the measurement value.

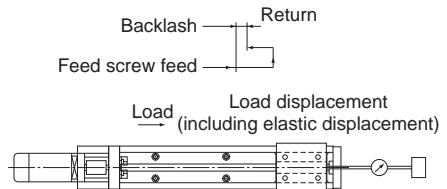

Fig.9 Backlash

The accuracies of model KR are classified into normal grade (no symbol), high accuracy grade (H) and precision grade (P). Tables below show standards for all the accuracies.

Table10 Normal Grade (No Symbol)

Unit: mm

Model No.	Stroke*	Outer rail length	Positioning Repeatability	Positioning Accuracy	Running Parallelism (Vertical Direction)	Backlash	Starting torque (N·cm)
KR20	30	100	±0.01	No standard defined	No standard defined	0.02	0.5
	80	150					
	130	200					
KR26	60	150	±0.01	No standard defined	No standard defined	0.02	1.5
	110	200					
	160	250					
KR30H	210	300	±0.01	No standard defined	No standard defined	0.02	7
	50	150					
	100	200					
	200	300					
	300	400					
KR33	400	500	±0.01	No standard defined	No standard defined	0.02	7
	500	600					
	600	700					
	200	340					
	300	440					
	400	540					
KR45H	500	640	±0.01	No standard defined	No standard defined	0.02	10
	600	740					
	700	840					
	800	940					
	190	340					
KR46	290	440	±0.01	No standard defined	No standard defined	0.02	10
	390	540					
	490	640					
	590	740					
	690	840					
	790	940					
KR55	800	980	±0.01	No standard defined	No standard defined	0.05	12
	900	1080					
	1000	1180					
	1100	1280					
	1200	1380					
KR65	790	980	±0.01	No standard defined	No standard defined	0.05	12
	990	1180					
	1190	1380					
	1490	1680	±0.012				15

\*Indicates stroke length when one long-type inner block is incorporated.

Note1) The evaluation method complies with THK standards.

Note2) Measurements are taken while using a motor provided by THK. For motor-wrap configuration, these values may not apply.

Note3) The starting torque represents the value when THK AFB-LF Grease is used. However, that of models KR20 and KR26 represents the value when THK AFA Grease is used, and that of KR15 represents the value when THK AFF Grease is used.

Note4) If highly viscous grease such as vacuum grease and clean room grease is used, the actual starting torque may exceed the corresponding value in the table. Use much care in selecting a motor.

Note5) Contact THK for accuracy information of units longer than the standard length.

Note6) Model KR15 is available in high accuracy grade (H) and precision grade (P) only.

Table11 High Accuracy Grade (H)

Unit: mm

Model No.	Stroke*	Outer rail length	Positioning accuracy repeatability	Positioning Accuracy	Running of Parallelism (Vertical direction)	Backlash	Starting torque (N-cm)
KR15	25	75	±0.004	0.04	0.02	0.01	0.4
	50	100					
	75	125					
	100	150					
	125	175					
	150	200					
KR20	30	100	±0.005	0.06	0.025	0.01	0.5
	80	150					
	130	200					
KR26	60	150	±0.005	0.06	0.025	0.01	1.5
	110	200					
	160	250					
	210	300					
KR30H	50	150	±0.005	0.06	0.025	0.02	7
	100	200		0.10			
	200	300					
	300	400					
	400	500					
	500	600					
KR33	50	150	±0.005	0.06	0.025	0.02	7
	100	200		0.10			
	200	300					
	300	400					
	400	500					
	500	600					
KR45H	200	340	±0.005	0.10	0.035	0.02	10
	300	440		0.12			
	400	540					
	500	640					
	600	740					
	700	840					
	800	940					
KR46	190	340	±0.005	0.10	0.035	0.02	10
	290	440		0.12			
	390	540					
	490	640					
	590	740					
	690	840					
KR55	790	940	±0.005	0.18	0.05	0.05	12
	800	980		0.25			
	900	1080					
	1000	1180					
KR65	1100	1280	±0.008	0.18	0.05	0.05	12
	1190	1380		0.20			
	1200	1380					
	1490	1680		0.28	0.055		

\*Indicates stroke length when one long-type inner block is incorporated.

Table12 Precision Grade (P)

Unit: mm

Model No.	Stroke*	Outer rail length	Positioning accuracy repeatability	Positioning Accuracy	Running of Parallelism (Vertical direction)	Backlash	Starting torque (N-cm)	
KR15	25	75	±0.003	0.02	0.01	0.002	0.8	
	50	100						
	75	125						
	100	150						
	125	175						
KR20	150	200	±0.003	0.02	0.01	0.003	1.2	
	30	100						
	80	150						
KR26	130	200	±0.003	0.02	0.01	0.003	4	
	60	150						
	110	200						
	160	250						
KR30H	210	300	±0.003	0.02	0.01	0.003	15	
	50	150						
	100	200						
	200	300		0.025	0.015			
	300	400						
	400	500						
KR33	500	600	±0.003	0.02	0.01	0.003	15	
	50	150						
	100	200						
	200	300		0.025	0.015			
	300	400						
	400	500						
KR45H	500	600	±0.003	0.025	0.015	0.003	15	
	600	700						
	200	340		0.03	0.02		17	
	300	440						
	400	540						
KR46	500	640	±0.003	0.025	0.015	0.003		15
	600	740						
	190	340						
	290	440		0.03	0.02		17	
	390	540						
	490	640						
	KR55	590		740	±0.005			0.035
690		840						
790		940	0.04	0.03				
800		980						
900		1080						
KR65	1000	1180	±0.005	0.035	0.025	0.005	22	
	790	980						
	990	1180						
	1190	1380		0.04	0.03			

\*Indicates stroke length when one long-type inner block is incorporated.

Note1) The evaluation method complies with THK standards.

Note2) Measurements are taken while using a motor provided by THK. For motor-wrap configuration, these values may not apply.

Note3) The starting torque represents the value when THK AFB-LF Grease is used.

However, that of models KR20 and KR26 represents the value when THK AFA Grease is used, and that of KR15 represents the value when THK AFF Grease is used.

Note4) If highly viscous grease such as vacuum grease and clean room grease is used, the actual starting torque may exceed the corresponding value in the table. Use much care in selecting a motor.

Note5) Contact THK for accuracy information of units longer than the standard length.

## Model Number Coding

Model No.	Ball Screw Lead	Inner block type	QZ Specification	Stroke	Accuracy
<b>KR33</b>	<b>10</b>	<b>A</b>	<b>QZ</b>	<b>0275</b>	<b>P</b>
①	②	③	④	⑤	⑥

KR15	01 : 1mm	A	No symbol : No QZ	0025 : 25mm	No symbol: normal grade
KR20	02 : 2mm	B	QZ	0050 : 50mm	H : High accuracy grade
KR26	06 : 6mm	C	QZA	}	P : Precision Grade
KR30H	10 : 10mm	D	QZB	1490 : 1490mm	
KR33	20 : 20mm		QZAD		
KR45H	25 : 25mm				
KR46					
KR55					
KR65					

QZ Specification ④ can be selected on the following models.

KR33 (→ **A2-118**)

KR46 (→ **A2-126**)

KR55 (→ **A2-130**)

KR65 (→ **A2-132**)

\*KR15, KR20, KR26, KR30H and KR45H cannot be selected.

If QZ, QZA, QZB, or QZAD is selected in QZ Specification ④, specify a stroke incorporating QZ. (→ **A2-135**)

If "2: with a bellows" has been selected in cover ⑧, specify a stroke incorporating the bellows. (→ **A2-146**)

The available ball screw leads differ depending on the model.

KR15 : "01", "02"

KR20 : "01", "06"

KR26 : "02", "06"

KR30H : "06", "10"

KR33 : "06", "10"

KR45H : "10", "20"

KR46 : "10", "20"

KR55 : "20"

KR65 : "25"

With/without a motor	Cover	Sensor	Housing A/ Intermediate Flange
<b>0</b>	<b>1</b>	<b>B</b>	<b>AQ</b>
⑦	⑧	⑨	⑩
0: direct-coupled (without a motor) 1: direct-coupled (with a motor, specified by the customer)	0: without a cover 1: with a cover 2: with a bellows	0: none 1 2 6 7 B E H L J M	10 30 40 A0 A5 A6 AN AP AQ AR AS AT AU AV AY AZ
If a selection has been made in QZ specification ④, "2: with a bellows" cannot be selected in Cover ⑧.			
If "0" is selected, a coupling is not attached. If a coupling is required, please indicate so.  "1" means that a motor specified by the customer is mounted. For item ⑨, select a housing A/intermediate flange that matches the specified motor.			

Several motors by different manufacturers can be mounted. Contact THK for details.

A type with a wrap-around housing A and a motor wrap-around type, which are not contained in the catalog, are also available. Contact THK for details.



## Model KR15 Standard Type

Model KR15□□A (with a Single Long Nut Block)

Model KR15□□B (with Two Long Nut Blocks)

For model number coding, see **A2-106**.

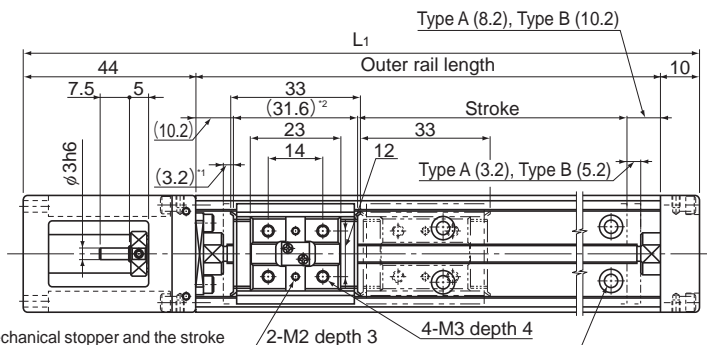

\*1 Distance between the mechanical stopper and the stroke starting position.

\*2 Indicates the inner block length when calculating the available stroke range. The length in model KR-B (with two long-type inner blocks) is 64.6 mm.

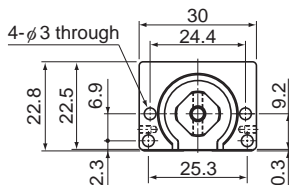
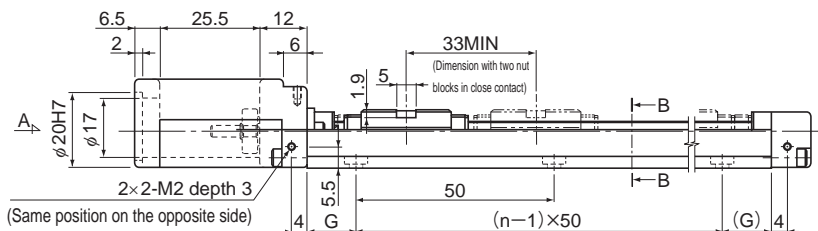

A arrow view

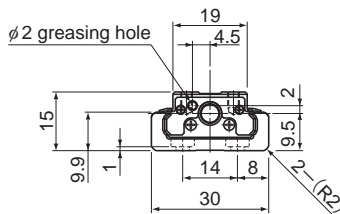

B-B cross section

Stroke (mm) (stroke between mechanical stoppers)		Outer rail length (mm)	Overall length $L_1$ (mm)	G (mm)	n	Overall main unit mass (kg)	
Type A	Type B					Type A	Type B
25(31.4)	—	75	129	12.5	2	0.2	—
50(56.4)	—	100	154	25	2	0.23	—
75(81.4)	40(48.4)	125	179	12.5	3	0.26	0.3
100(106.4)	65(73.4)	150	204	25	3	0.29	0.33
125(131.4)	90(98.4)	175	229	12.5	4	0.32	0.36
150(156.4)	115(123.4)	200	254	25	4	0.35	0.39

\*Indicates a value when two inner blocks are in close contact with each other.

## Model KR15 (with a Cover)

Model KR15□□A (with a Single Long Nut Block)

Model KR15□□B (with Two Long Nut Blocks)

For model number coding, see **A2-106**.

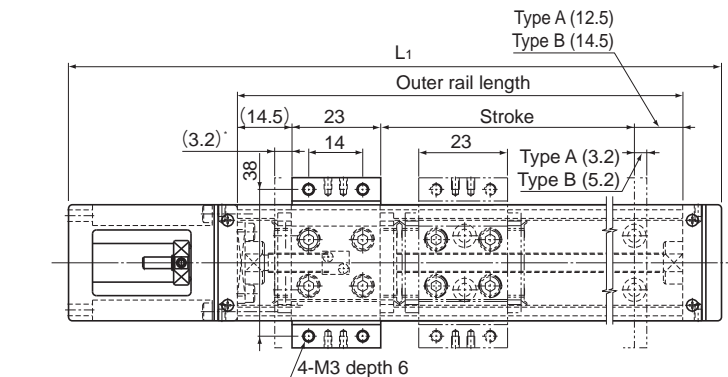

\* Distance between the mechanical stopper and the stroke starting position.

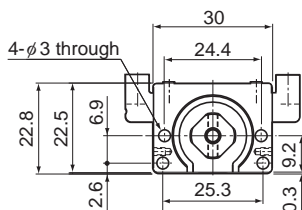
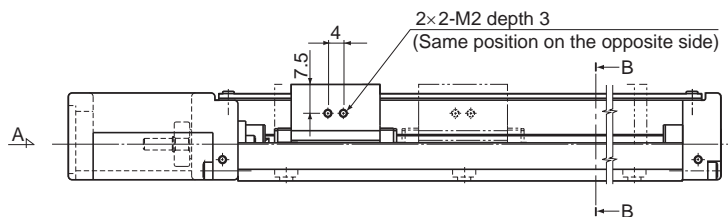

A arrow view

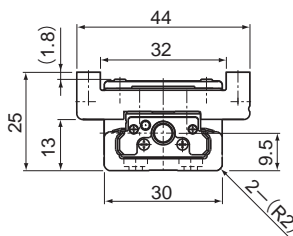

B-B cross section

Stroke (mm) (stroke between mechanical stoppers)		Outer rail length (mm)	Overall length L <sub>1</sub> (mm)	Overall main unit mass (kg)	
Type A	Type B			Type A	Type B
25(31.4)	—	75	129	0.25	—
50(56.4)	—	100	154	0.28	—
75(81.4)	40(48.4)	125	179	0.32	0.39
100(106.4)	65(73.4)	150	204	0.35	0.42
125(131.4)	90(98.4)	175	229	0.38	0.45
150(156.4)	115(123.4)	200	254	0.41	0.48

\*Indicates a value when two inner blocks are in close contact with each other.

## Model KR20 Standard Type

Model KR20□□A (with a Single Long Nut Block)

Model KR20□□B (with Two Long Nut Blocks)

For model number coding, see **A2-106**.

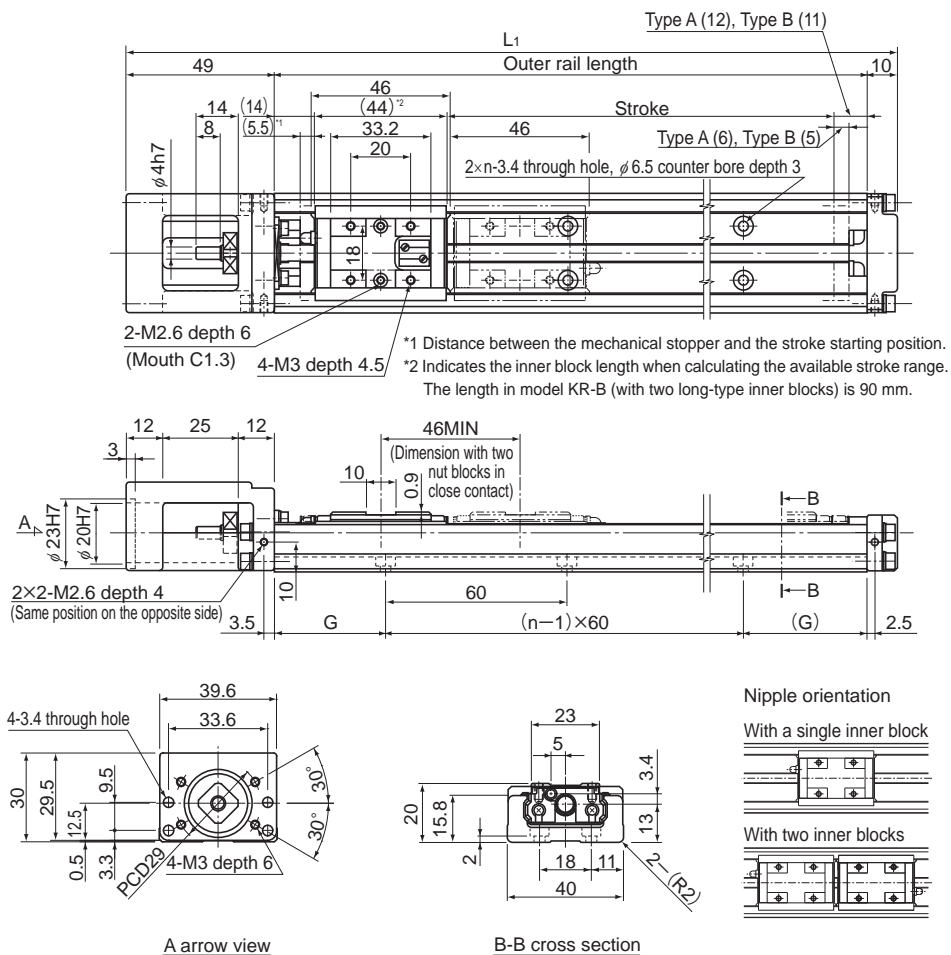

Stroke (mm) (stroke between mechanical stoppers)		Outer rail length (mm)	Overall length $L_1$ (mm)	G (mm)	n	Overall main unit mass (kg)	
Type A	Type B					Type A	Type B
30(41.5)	—	100	159	20	2	0.48	—
80(91.5)	35(45.5)	150	209	15	3	0.61	0.69
130(141.5)	85(95.5)	200	259	40	3	0.75	0.83

\*Indicates a value when two inner blocks are in close contact with each other.

## Model KR20 (with a Cover)

Model KR20□□A (with a Single Long Nut Block)

Model KR20□□B (with Two Long Nut Blocks)

For model number coding, see **A2-106**.

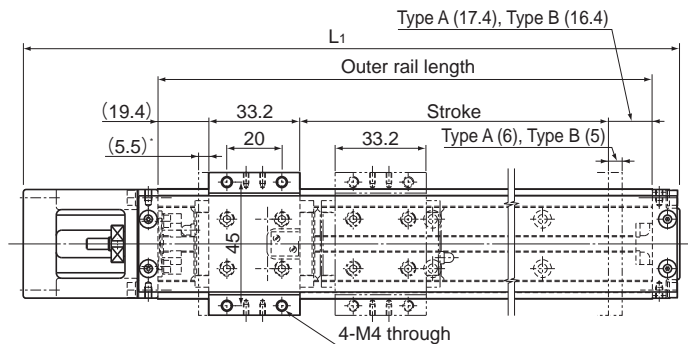

\* Distance between the mechanical stopper and the stroke starting position.

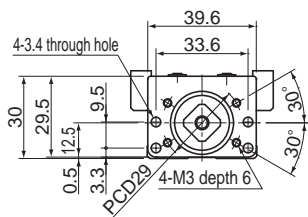
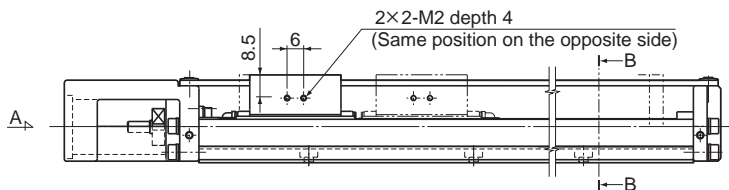

A arrow view

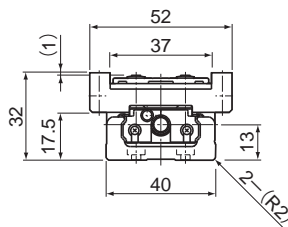

B-B cross section

Stroke (mm) (stroke between mechanical stoppers)		Outer rail length (mm)	Overall length $L_1$ (mm)	Overall main unit mass (kg)	
Type A	Type B			Type A	Type B
30(41.5)	—	100	159	0.56	—
80(91.5)	35(45.5)	150	209	0.71	0.84
130(141.5)	85(95.5)	200	259	0.85	0.98

\*Indicates a value when two inner blocks are in close contact with each other.

## Model KR26 Standard Type

Model KR26□□A (with a Single Long Nut Block)

Model KR26□□B (with Two Long Nut Blocks)

For model number coding, see **A2-106**.

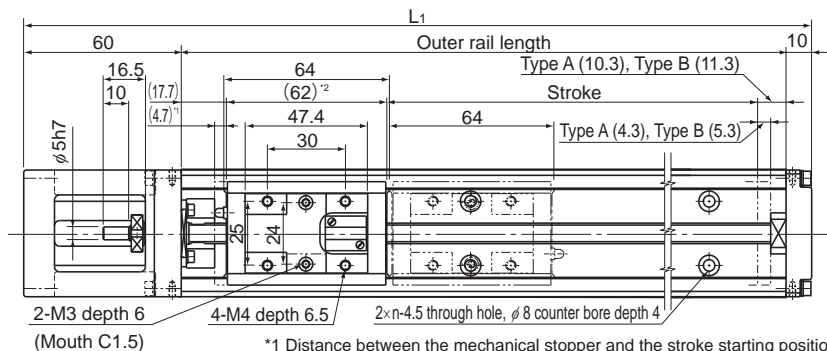

\*1 Distance between the mechanical stopper and the stroke starting position.

\*2 Indicates the inner block length when calculating the available stroke range.  
The length in model KR-B (with two long-type inner blocks) is 126 mm.

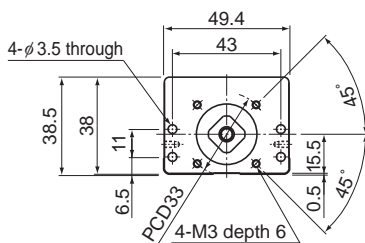
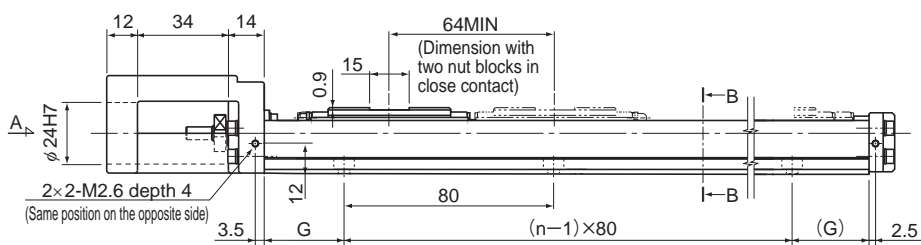

A arrow view

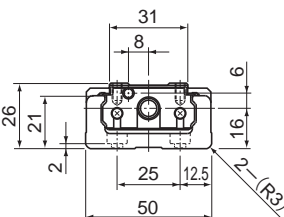

B-B cross section

Nipple orientation

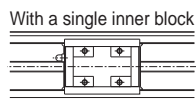

With two inner blocks

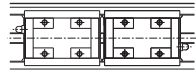

Stroke (mm) (stroke between mechanical stoppers)		Outer rail length (mm)	Overall length $L_1$ (mm)	G (mm)	n	Overall main unit mass (kg)	
Type A	Type B <sup>*</sup>					Type A	Type B
60(69)	—	150	220	35	2	1.04	—
110(119)	45(55)	200	270	20	3	1.25	1.44
160(169)	95(105)	250	320	45	3	1.46	1.65
210(219)	145(155)	300	370	30	4	1.67	1.86

\*Indicates a value when two inner blocks are in close contact with each other.

## Model KR26 (with a Cover)

Model KR26□□A (with a Single Long Nut Block)

Model KR26□□B (with Two Long Nut Blocks)

For model number coding, see **A2-106**.

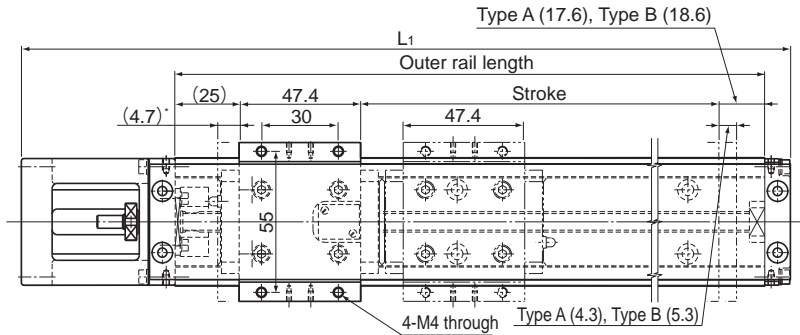

\* Distance between the mechanical stopper and the stroke starting position.

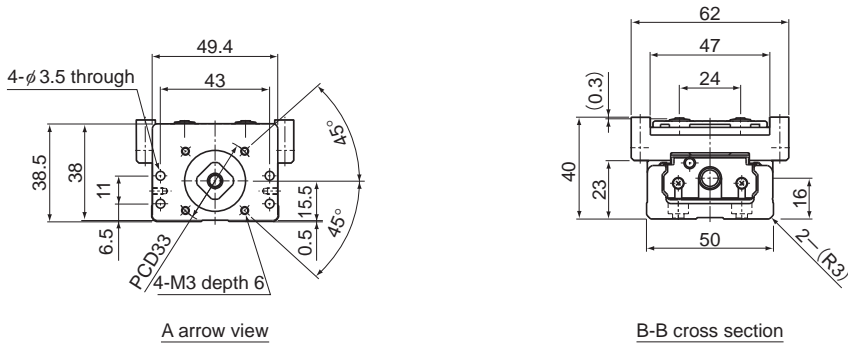
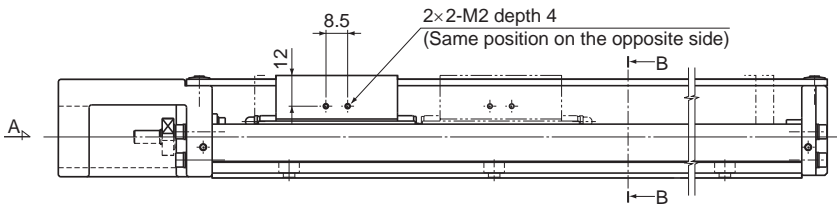

Stroke (mm) (stroke between mechanical stoppers)		Outer rail length (mm)	Overall length $L_1$ (mm)	Overall main unit mass (kg)	
Type A	Type B			Type A	Type B
60(69)	—	150	220	1.2	—
110(119)	45(55)	200	270	1.42	1.7
160(169)	95(105)	250	320	1.65	1.93
210(219)	145(155)	300	370	1.87	2.15

\*Indicates a value when two inner blocks are in close contact with each other.

# Model KR30H Standard Type

Model KR30H□□A (with a Single Long Nut Block)

Model KR30H□□B (with Two Long Nut Blocks)

For model number coding, see **A2-106**.

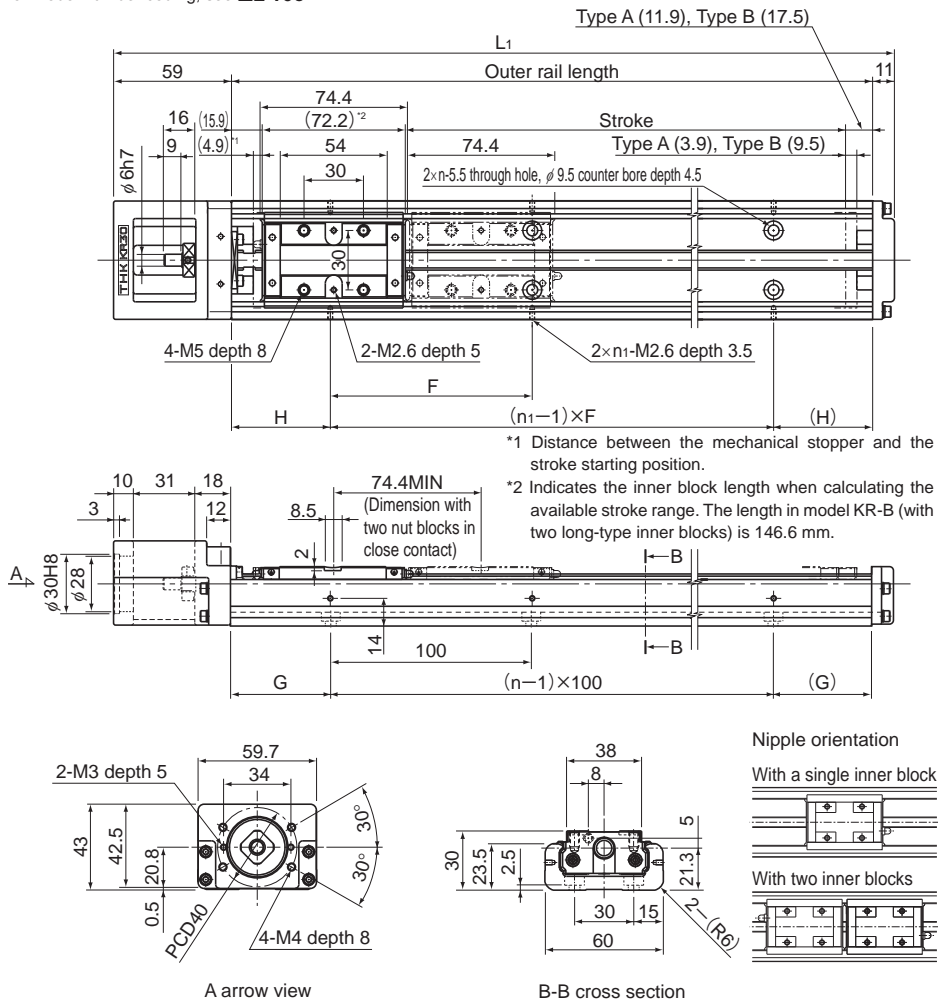

Stroke (mm) (stroke between mechanical stoppers)		Outer rail length (mm)	Overall length L <sub>1</sub> (mm)	H (mm)	G (mm)	F (mm)	n	n <sub>1</sub>	Overall main unit mass (kg)	
Type A	Type B								Type A	Type B
50(58.8)	—	150	220	25	25	100	2	2	1.6	—
100(108.8)	—	200	270	50	50	100	2	2	1.9	—
200(208.8)	120(134.4)	300	370	50	50	200	3	2	2.5	2.9
300(308.8)	220(234.4)	400	470	100	50	200	4	2	3	3.4
400(408.8)	320(334.4)	500	570	50	50	200	5	3	3.6	4
500(508.8)	420(434.4)	600	670	100	50	200	6	3	4.2	4.6

\*Indicates a value when two inner blocks are in close contact with each other.

## Model KR30H (with a Cover)

Model KR30H□□A (with a Single Long Nut Block)

Model KR30H□□B (with Two Long Nut Blocks)

For model number coding, see **A2-106**.

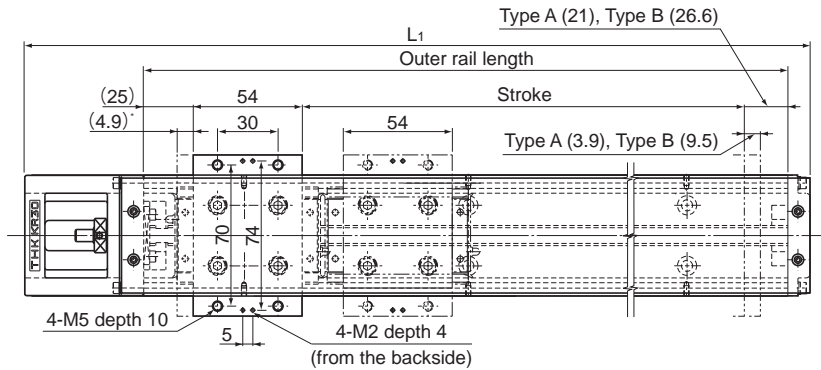

\* Distance between the mechanical stopper and the stroke starting position.

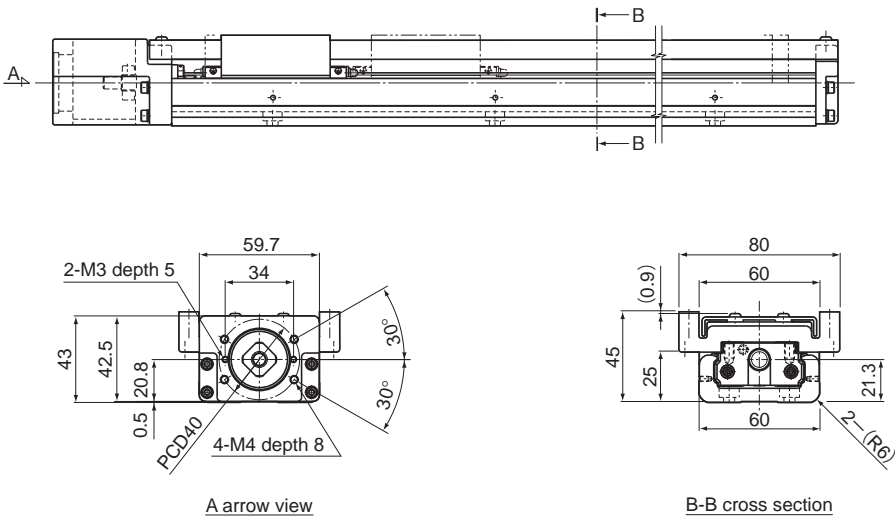

Stroke (mm) (stroke between mechanical stoppers)		Outer rail length (mm)	Overall length $L_1$ (mm)	Overall main unit mass (kg)	
Type A	Type B			Type A	Type B
50(58.8)	—	150	220	1.9	—
100(108.8)	—	200	270	2.2	—
200(208.8)	120(134.4)	300	370	2.8	3.4
300(308.8)	220(234.4)	400	470	3.4	4
400(408.8)	320(334.4)	500	570	4	4.6
500(508.8)	420(434.4)	600	670	4.6	5.2

\*Indicates a value when two inner blocks are in close contact with each other.



# Model KR30H Standard Type

Model KR30H□□C (with a Single Short Nut Block)

Model KR30H□□D (with Two Short Nut Blocks)

For model number coding, see **A2-106**.

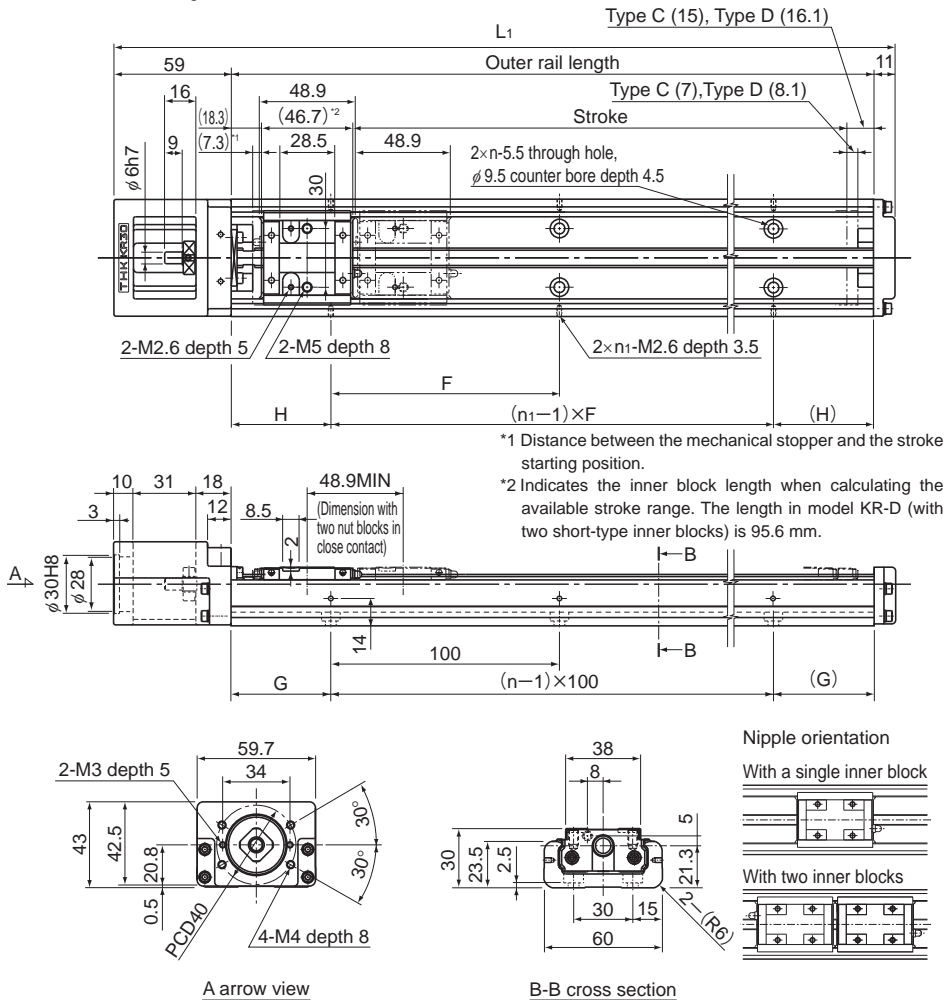

A arrow view

B-B cross section

Stroke (mm) (stroke between mechanical stoppers)		Outer rail length (mm)	Overall length L <sub>1</sub> (mm)	H (mm)	G (mm)	F (mm)	n	n <sub>1</sub>	Overall main unit mass (kg)	
Type C	Type D								Type C	Type D
70(84.3)	20(35.4)	150	220	25	25	100	2	2	1.4	1.6
120(134.3)	70(85.4)	200	270	50	50	100	2	2	1.7	1.9
220(234.3)	170(185.4)	300	370	50	50	200	3	2	2.3	2.5
320(334.3)	270(285.4)	400	470	100	50	200	4	2	2.8	3
420(434.3)	370(385.4)	500	570	50	50	200	5	3	3.4	3.6
520(534.3)	470(485.4)	600	670	100	50	200	6	3	4	4.2

\*Indicates a value when two inner blocks are in close contact with each other.

## Model KR30H (with a Cover)

Model KR30H□□C (with a Single Short Nut Block)

Model KR30H□□D (with Two Short Nut Blocks)

For model number coding, see **A2-106**.

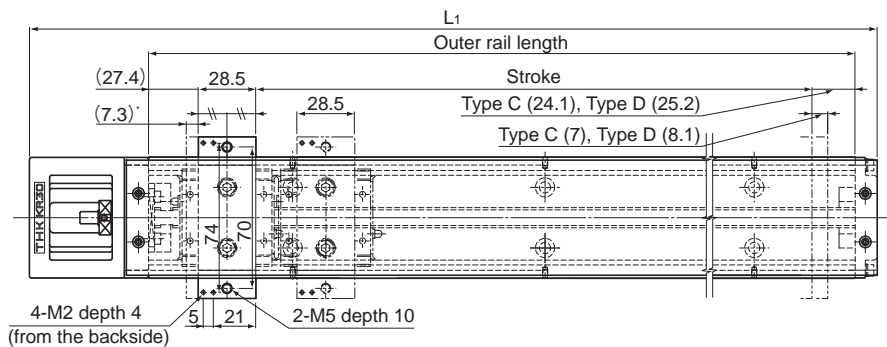

\* Distance between the mechanical stopper and the stroke starting position.

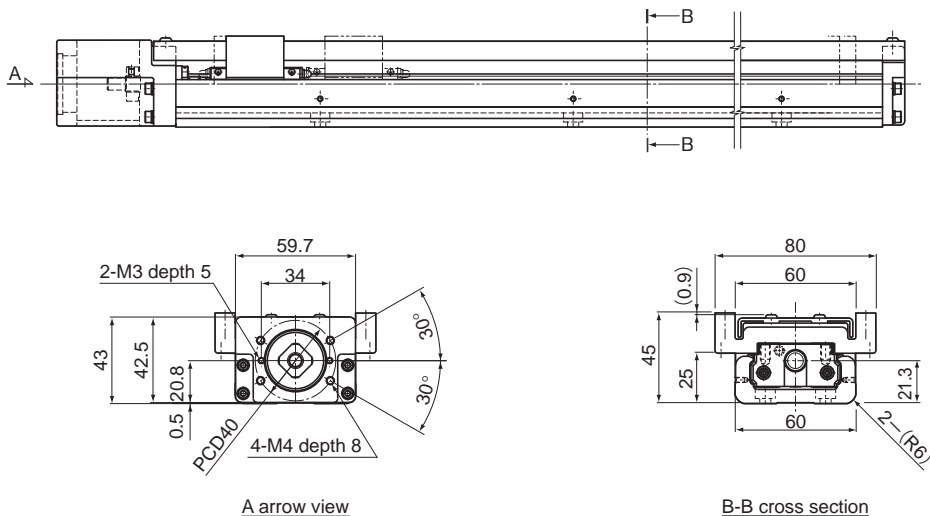

A arrow view

B-B cross section

Stroke (mm) (stroke between mechanical stoppers)		Outer rail length (mm)	Overall length $L_1$ (mm)	Overall main unit mass (kg)	
Type C	Type D			Type C	Type D
70(84.3)	20(35.4)	150	220	1.6	1.9
120(134.3)	70(85.4)	200	270	1.9	2.2
220(234.3)	170(185.4)	300	370	2.5	2.8
320(334.3)	270(285.4)	400	470	3.1	3.4
420(434.3)	370(385.4)	500	570	3.7	4
520(534.3)	470(485.4)	600	670	4.3	4.6

\*Indicates a value when two inner blocks are in close contact with each other.

# Model KR33 Standard Type

Model KR33□□A (with a Single Long Nut Block)

Model KR33□□B (with Two Long Nut Blocks)

For model number coding, see **A2-106**.

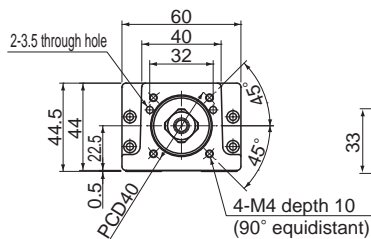
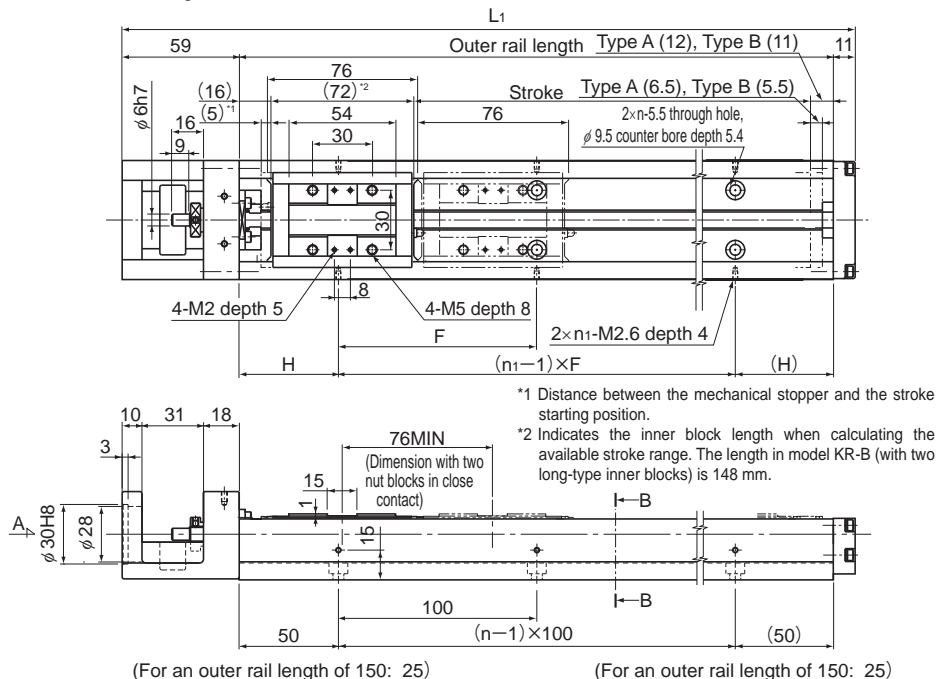

Nipple orientation

With a single inner block

With two inner blocks

Stroke (mm) (stroke between mechanical stoppers)		Outer rail length (mm)	Overall length L <sub>1</sub> (mm)	H (mm)	F (mm)	n	n <sub>1</sub>	Overall main unit mass (kg)	
Type A	Type B <sup>*</sup>							Type A	Type B
50(61.5)	—	150	220	25	100	2	2	1.9	—
100(111.5)	—	200	270	50	100	2	2	2.2	—
200(211.5)	125(135.5)	300	370	50	200	3	2	3	3.4
300(311.5)	225(235.5)	400	470	100	200	4	2	3.7	4.1
400(411.5)	325(335.5)	500	570	50	200	5	3	4.4	4.8
500(511.5)	425(435.5)	600	670	100	200	6	3	5.2	5.6
600(611.5)	525(535.5)	700	770	50	200	7	4	5.9	6.3

<sup>\*</sup>Indicates a value when two inner blocks are in close contact with each other.

## Model KR33 (with a Cover)

Model KR33□□A (with a Single Long Nut Block)

Model KR33□□B (with Two Long Nut Blocks)

For model number coding, see **A2-106**.

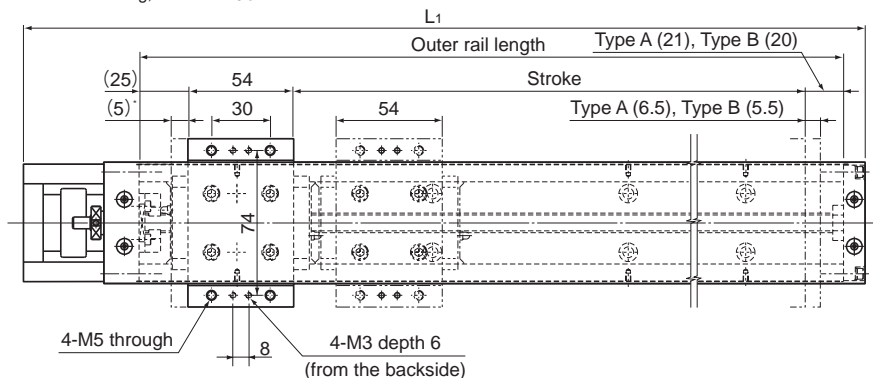

\* Distance between the mechanical stopper and the stroke starting position.

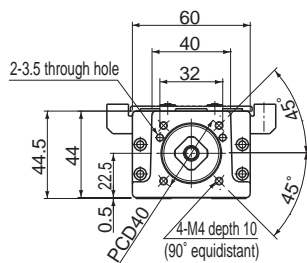
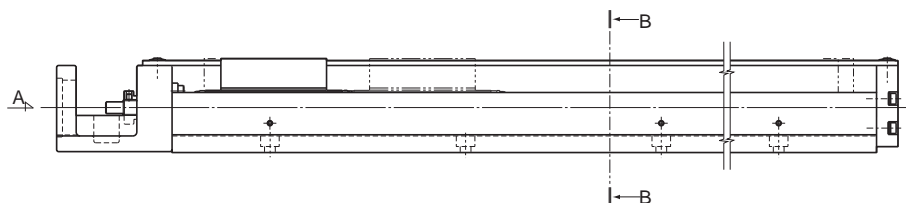

A arrow view

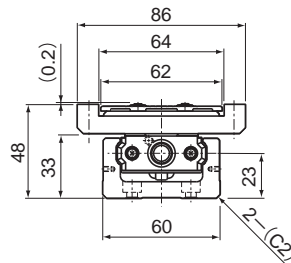

B-B cross section

Stroke (mm) (stroke between mechanical stoppers)		Outer rail length (mm)	Overall length $L_1$ (mm)	Overall main unit mass (kg)	
Type A	Type B*			Type A	Type B
50(61.5)	—	150	220	2.2	—
100(111.5)	—	200	270	2.6	—
200(211.5)	125(135.5)	300	370	3.3	3.9
300(311.5)	225(235.5)	400	470	4.1	4.7
400(411.5)	325(335.5)	500	570	4.9	5.5
500(511.5)	425(435.5)	600	670	5.6	6.2
600(611.5)	525(535.5)	700	770	6.4	7

\*Indicates a value when two inner blocks are in close contact with each other.

Note) It must be noted that the cover-mounting bolt is 0.2 mm higher than the top face of the top table.

# Model KR33 Standard Type

Model KR33□□C (with a Single Short Nut Block)

Model KR33□□D (with Two Short Nut Blocks)

For model number coding, see **A2-106**.

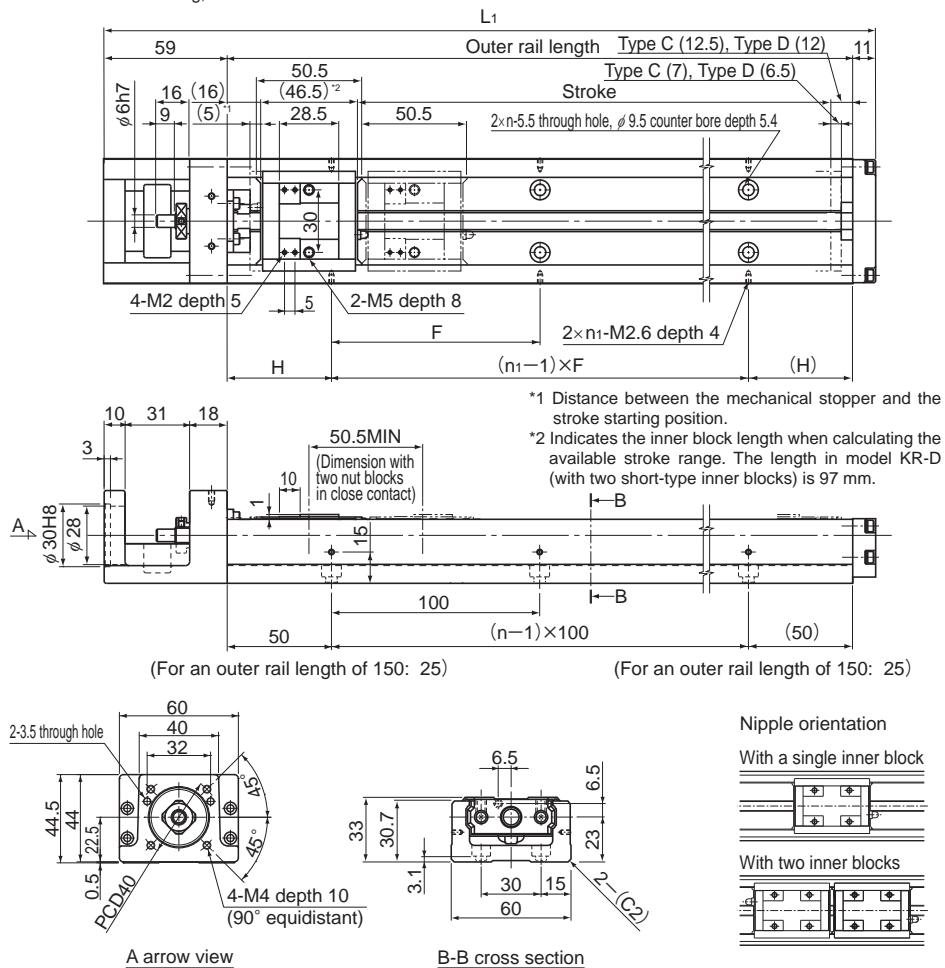

Stroke (mm) (stroke between mechanical stoppers)		Outer rail length (mm)	Overall length $L_1$ (mm)	H (mm)	F (mm)	n	$n_1$	Overall main unit mass (kg)	
Type C	Type D*							Type C	Type D
75(87)	25(36.5)	150	220	25	100	2	2	1.7	1.9
125(137)	75(86.5)	200	270	50	100	2	2	2	2.2
225(237)	175(186.5)	300	370	50	200	3	2	2.8	3
325(337)	275(286.5)	400	470	100	200	4	2	3.5	3.7
425(437)	375(386.5)	500	570	50	200	5	3	4.2	4.4
525(537)	475(486.5)	600	670	100	200	6	3	5	5.2
625(637)	575(586.5)	700	770	50	200	7	4	5.7	5.9

\*Indicates a value when two inner blocks are in close contact with each other.

## Model KR33 (with a Cover)

Model KR33□□C (with a Single Short Nut Block)

Model KR33□□D (with Two Short Nut Blocks)

For model number coding, see **A2-106**.

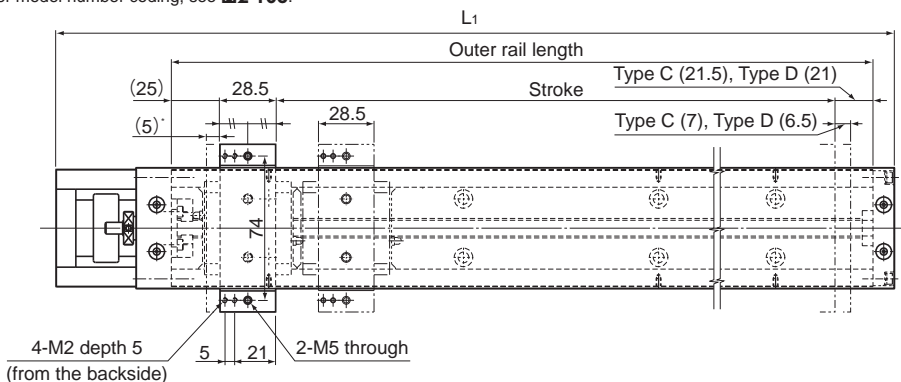

\* Distance between the mechanical stopper and the stroke starting position.

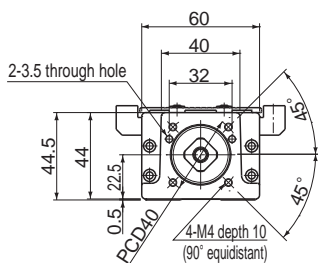
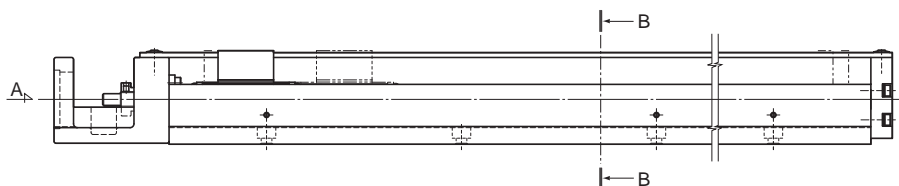

A arrow view

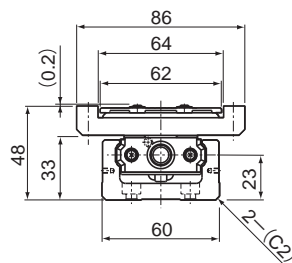

B-B cross section

Stroke (mm) (stroke between mechanical stoppers)		Outer rail length (mm)	Overall length $L_1$ (mm)	Overall main unit mass (kg)	
Type C	Type D			Type C	Type D
75(87)	25(36.5)	150	220	1.9	2.2
125(137)	75(86.5)	200	270	2.3	2.6
225(237)	175(186.5)	300	370	3	3.3
325(337)	275(286.5)	400	470	3.8	4.1
425(437)	375(386.5)	500	570	4.6	4.9
525(537)	475(486.5)	600	670	5.3	5.6
625(637)	575(586.5)	700	770	6.1	6.4

\*Indicates a value when two inner blocks are in close contact with each other.

Note) It must be noted that the cover-mounting bolt is 0.2 mm higher than the top face of the top table.

# Model KR45H Standard Type

Model KR45H□□A (with a Single Long Nut Block)

Model KR45H□□B (with Two Long Nut Blocks)

For model number coding, see **A2-106**.

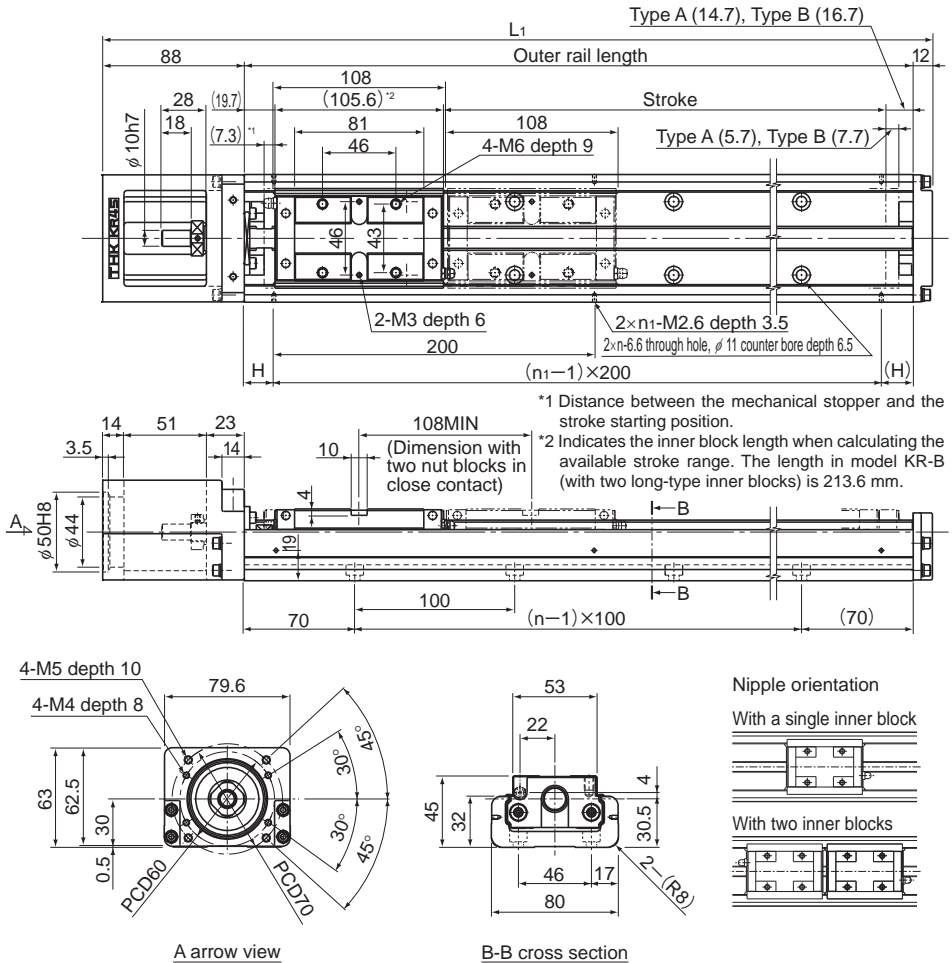

Stroke (mm) (stroke between mechanical stoppers)		Outer rail length (mm)	Overall length $L_1$ (mm)	H (mm)	n	$n_1$	Overall main unit mass (kg)	
Type A	Type B <sup>*</sup>						Type A	Type B
200(213)	90(105)	340	440	70	3	2	5.4	6.4
300(313)	190(205)	440	540	20	4	3	6.5	7.5
400(413)	290(305)	540	640	70	5	3	7.5	8.5
500(513)	390(405)	640	740	20	6	4	8.6	9.6
600(613)	490(505)	740	840	70	7	4	9.7	10.7
700(713)	590(605)	840	940	20	8	5	10.7	11.7
800(813)	690(705)	940	1040	70	9	5	11.8	12.8

\*Indicates a value when two inner blocks are in close contact with each other.

## Model KR45H (with a Cover)

Model KR45H□□A (with a Single Long Nut Block)

Model KR45H□□B (with Two Long Nut Blocks)

For model number coding, see **A2-106**.

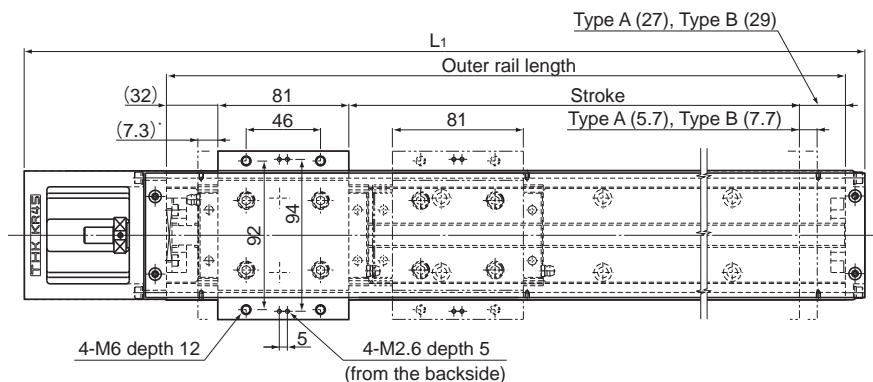

\* Distance between the mechanical stopper and the stroke starting position.

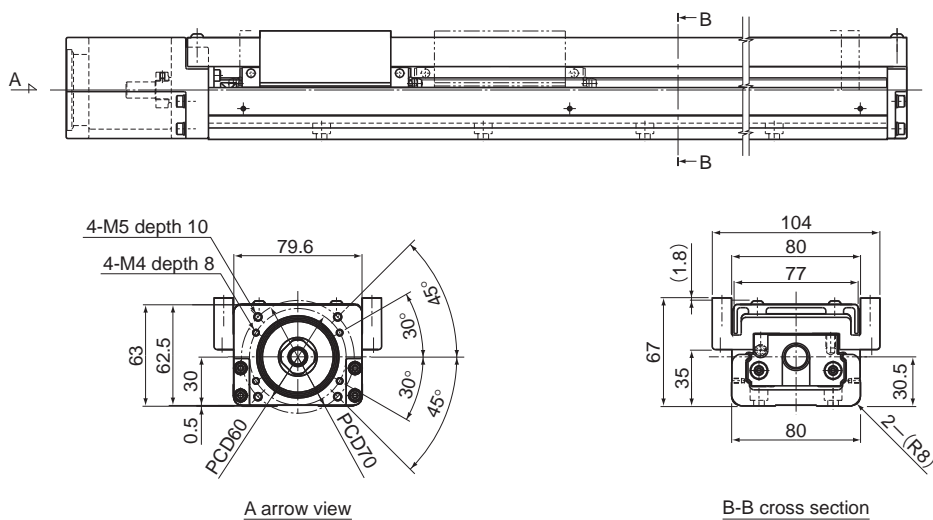

Stroke (mm) (stroke between mechanical stoppers)		Outer rail length (mm)	Overall length L <sub>1</sub> (mm)	Overall main unit mass (kg)	
Type A	Type B <sup>*</sup>			Type A	Type B
200(213)	90(105)	340	440	6.4	7.8
300(313)	190(205)	440	540	7.6	9
400(413)	290(305)	540	640	8.7	10.1
500(513)	390(405)	640	740	9.9	11.3
600(613)	490(505)	740	840	11	12.4
700(713)	590(605)	840	940	12.2	13.6
800(813)	690(705)	940	1040	13.3	14.7

\*Indicates a value when two inner blocks are in close contact with each other.



## Model KR45H Standard Type

Model KR45H□□C (with a Single Short Nut Block)

Model KR45H□□D (with Two Short Nut Blocks)

For model number coding, see **A2-106**.

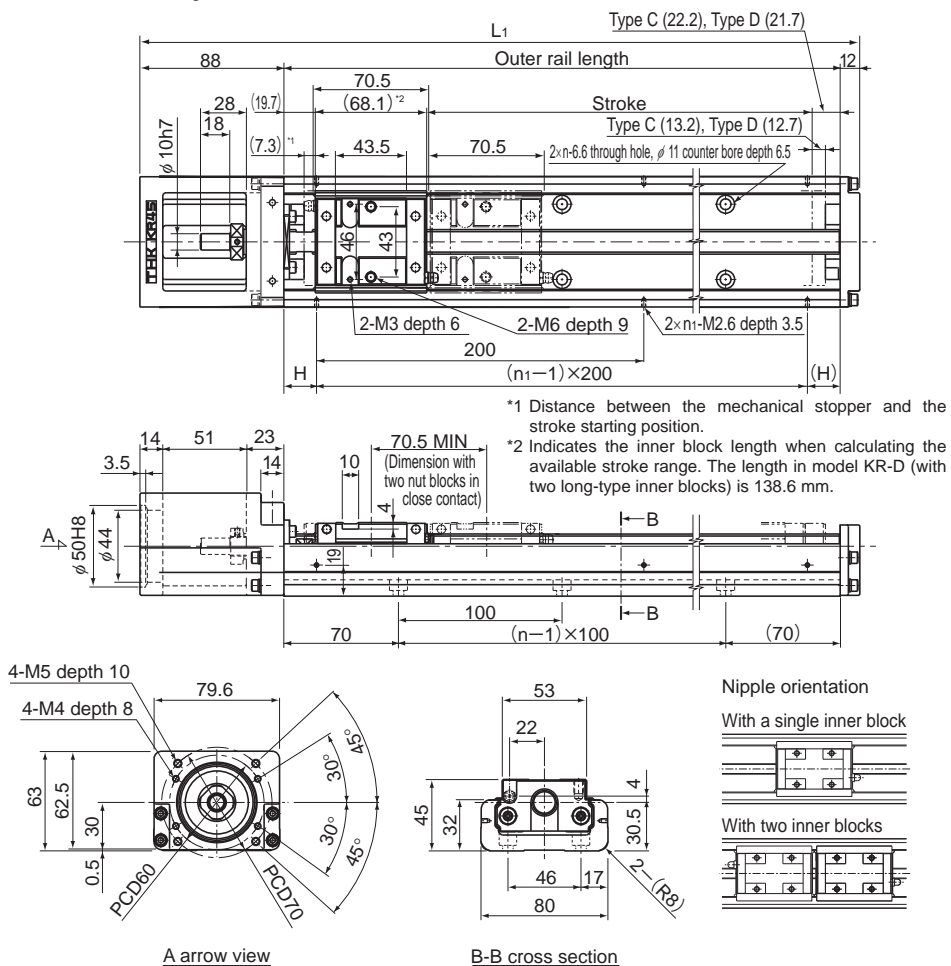

Stroke (mm) (stroke between mechanical stoppers)		Outer rail length (mm)	Overall length $L_1$ (mm)	H (mm)	n	$n_1$	Overall main unit mass (kg)	
Type C	Type D <sup>*</sup>						Type C	Type D
230(250.5)	160(180)	340	440	70	3	2	5	5.6
330(350.5)	260(280)	440	540	70	4	3	6.1	6.7
430(450.5)	360(380)	540	640	70	5	3	7.1	7.7
530(550.5)	460(480)	640	740	20	6	4	8.2	8.8
630(650.5)	560(580)	740	840	70	7	4	9.3	9.9
730(750.5)	660(680)	840	940	20	8	5	10.3	10.9
830(850.5)	760(780)	940	1040	70	9	5	11.4	12

<sup>\*</sup>Indicates a value when two inner blocks are in close contact with each other.

## Model KR45H (with a Cover)

Model KR45H□□C (with a Single Short Nut Block)

Model KR45H□□D (with Two Short Nut Blocks)

For model number coding, see **A2-106**.

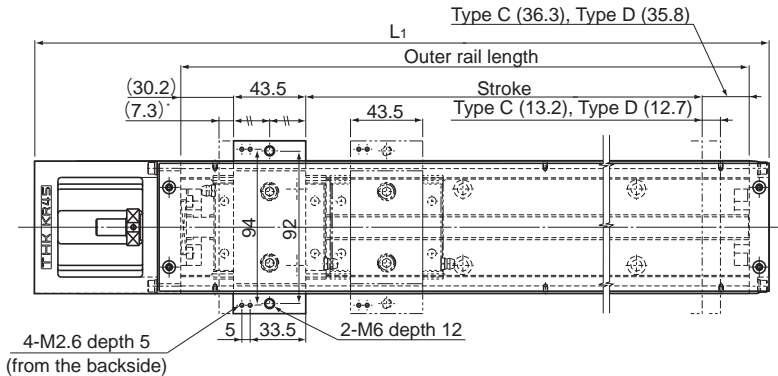

\* Distance between the mechanical stopper and the stroke starting position.

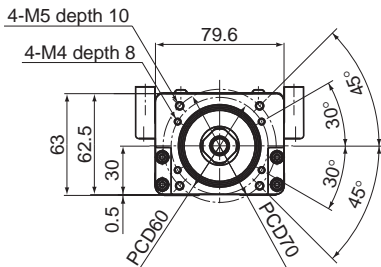
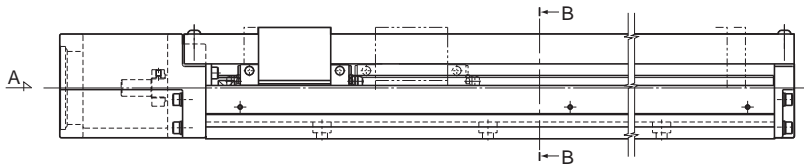

A arrow view

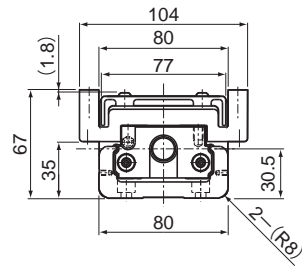

B-B cross section

Stroke (mm) (stroke between mechanical stoppers)		Outer rail length (mm)	Overall length $L_1$ (mm)	Overall main unit mass (kg)	
Type C	Type D			Type C	Type D
230(250.5)	160(180)	340	440	5.8	6.6
330(350.5)	260(280)	440	540	7	7.8
430(450.5)	360(380)	540	640	8.1	8.9
530(550.5)	460(480)	640	740	9.3	10.1
630(650.5)	560(580)	740	840	10.4	11.2
730(750.5)	660(680)	840	940	11.6	12.4
830(850.5)	760(780)	940	1040	12.7	13.5

\*Indicates a value when two inner blocks are in close contact with each other.

# Model KR46 Standard Type

Model KR46□□A (with a Single Long Nut Block)

Model KR46□□B (with Two Long Nut Blocks)

For model number coding, see **A2-106**.

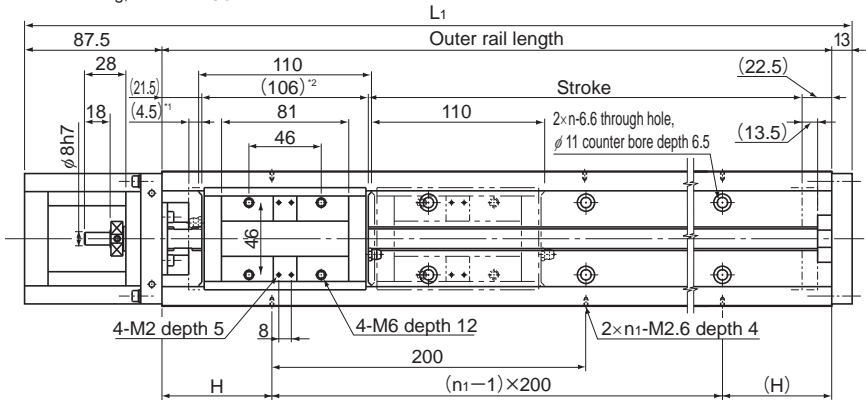

\*1 Distance between the mechanical stopper and the stroke starting position.

\*2 Indicates the inner block length when calculating the available stroke range. The length in model KR-B (with two long-type inner blocks) is 216 mm.

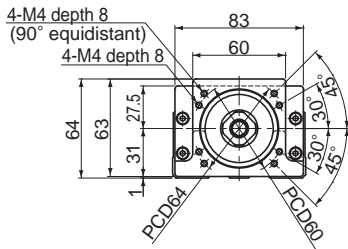
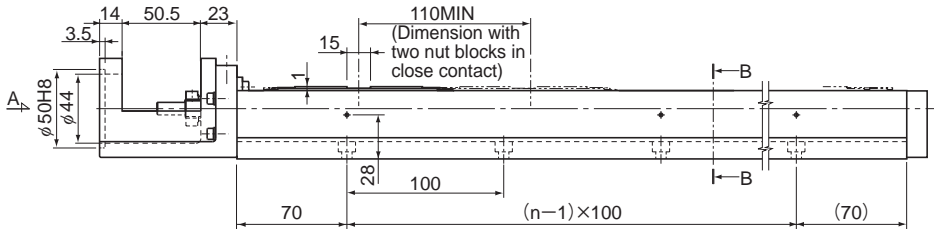

A arrow view

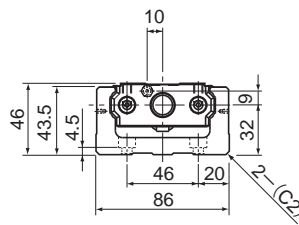

B-B cross section

Nipple orientation

With a single inner block

With two inner blocks

Stroke (mm) (stroke between mechanical stoppers)		Outer rail length (mm)	Overall length L <sub>1</sub> (mm)	H (mm)	n	n <sub>1</sub>	Overall main unit mass (kg)	
Type A	Type B						Type A	Type B
190(208)	80(98)	340	440.5	70	3	2	6.6	7.6
290(308)	180(198)	440	540.5	20	4	3	8	9
390(408)	280(298)	540	640.5	70	5	3	9.4	10.4
490(508)	380(398)	640	740.5	20	6	4	10.8	11.8
590(608)	480(498)	740	840.5	70	7	4	12.2	13.2
690(708)	580(598)	840	940.5	20	8	5	13.6	14.6
790(808)	680(698)	940	1040.5	70	9	5	15	16

\*Indicates a value when two inner blocks are in close contact with each other.

## Model KR46 (with a Cover)

Model KR46□□A (with a Single Long Nut Block)

Model KR46□□B (with Two Long Nut Blocks)

For model number coding, see **A2-106**.

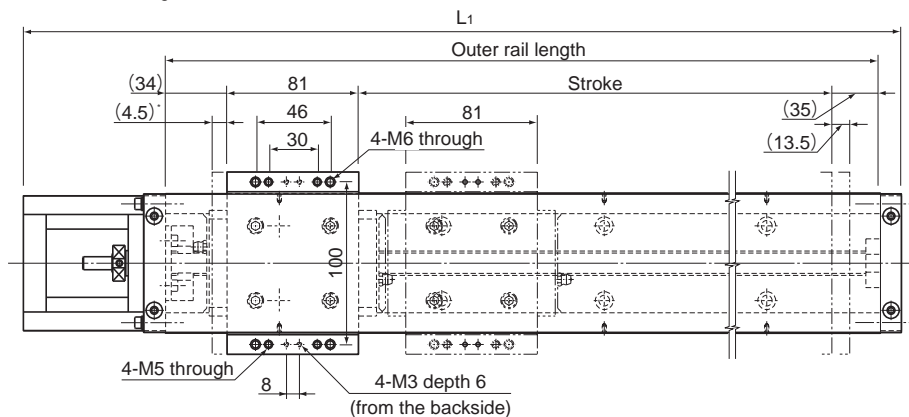

\* Distance between the mechanical stopper and the stroke starting position.

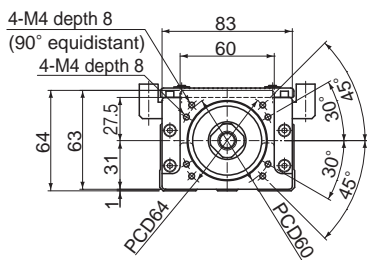
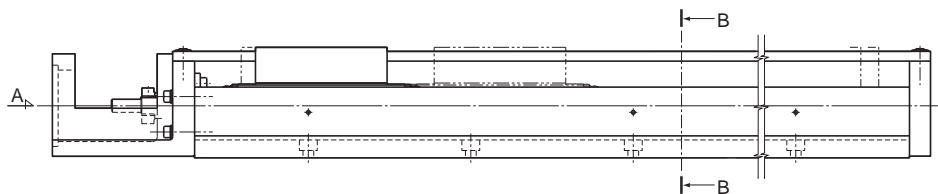

A arrow view

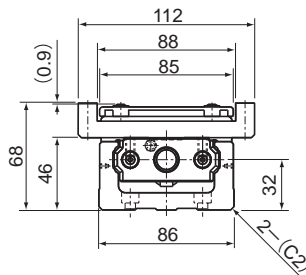

B-B cross section

Stroke (mm) (stroke between mechanical stoppers)		Outer rail length (mm)	Overall length L <sub>1</sub> (mm)	Overall main unit mass (kg)	
Type A	Type B <sup>*</sup>			Type A	Type B
190(208)	80(98)	340	440.5	7.5	8.9
290(308)	180(198)	440	540.5	9	10.4
390(408)	280(298)	540	640.5	10.5	11.9
490(508)	380(398)	640	740.5	12	13.4
590(608)	480(498)	740	840.5	13.5	14.9
690(708)	580(598)	840	940.5	14.9	16.3
790(808)	680(698)	940	1040.5	16.4	17.8

\*Indicates a value when two inner blocks are in close contact with each other.

# Model KR46 Standard Type

Model KR46□□C (with a Single Short Nut Block)

Model KR46□□D (with Two Short Nut Blocks)

For model number coding, see **A2-106**.

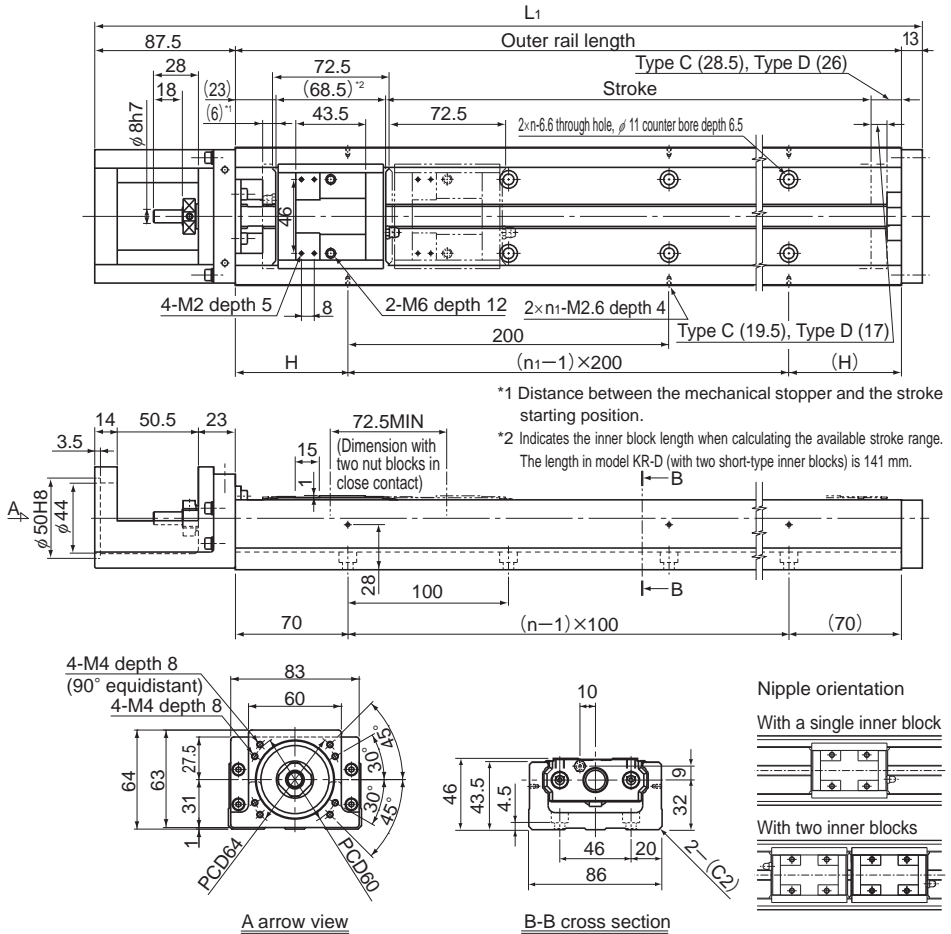

Stroke (mm) (stroke between mechanical stoppers)		Outer rail length (mm)	Overall length $L_1$ (mm)	H (mm)	n	$n_1$	Overall main unit mass (kg)	
Type C	Type D'						Type C	Type D
220(245.5)	150(173)	340	440.5	70	3	2	6.2	6.8
320(345.5)	250(273)	440	540.5	20	4	3	7.6	8.2
420(445.5)	350(373)	540	640.5	70	5	3	9	9.6
520(545.5)	450(473)	640	740.5	20	6	4	10.4	11
620(645.5)	550(573)	740	840.5	70	7	4	11.8	12.4
720(745.5)	650(673)	840	940.5	20	8	5	13.2	13.8
820(845.5)	750(773)	940	1040.5	70	9	5	14.6	15.2

\*Indicates a value when two inner blocks are in close contact with each other.

## Model KR46 (with a Cover)

Model KR46□□C (with a Single Short Nut Block)

Model KR46□□D (with Two Short Nut Blocks)

For model number coding, see **A2-106**.

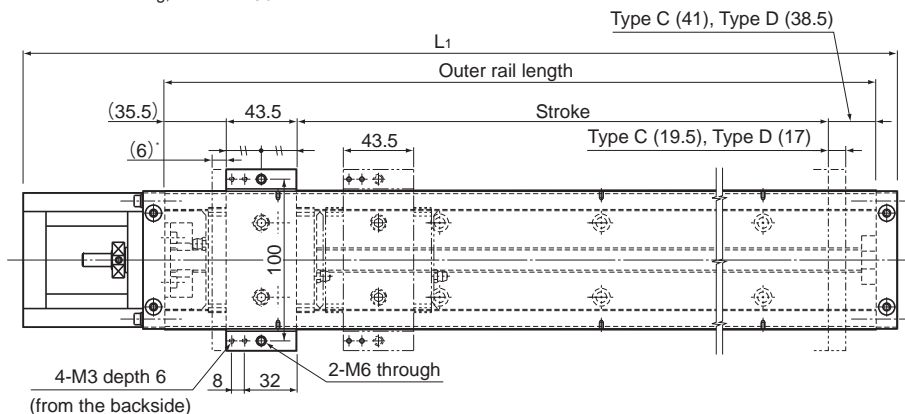

\* Distance between the mechanical stopper and the stroke starting position.

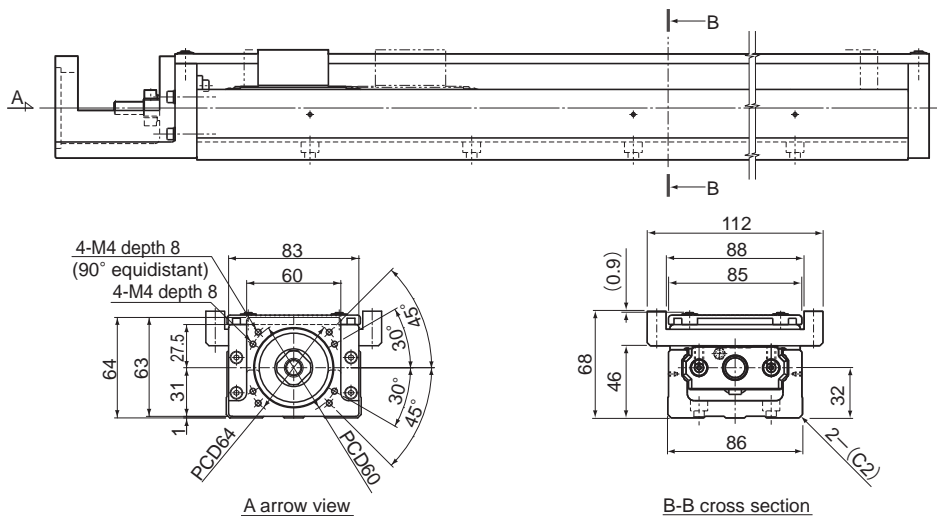

Stroke (mm) (stroke between mechanical stoppers)		Outer rail length (mm)	Overall length $L_1$ (mm)	Overall main unit mass (kg)	
Type C	Type D			Type C	Type D
220(245.5)	150(173)	340	440.5	6.9	7.7
320(345.5)	250(273)	440	540.5	8.4	9.2
420(445.5)	350(373)	540	640.5	9.9	10.7
520(545.5)	450(473)	640	740.5	11.4	12.2
620(645.5)	550(573)	740	840.5	12.9	13.7
720(745.5)	650(673)	840	940.5	14.3	15.1
820(845.5)	750(773)	940	1040.5	15.8	16.6

\*Indicates a value when two inner blocks are in close contact with each other.

## Model KR55 Standard Type

Model KR5520A (with a Single Long Nut Block)

Model KR5520B (with Two Long Nut Blocks)

For model number coding, see **A2-106**.

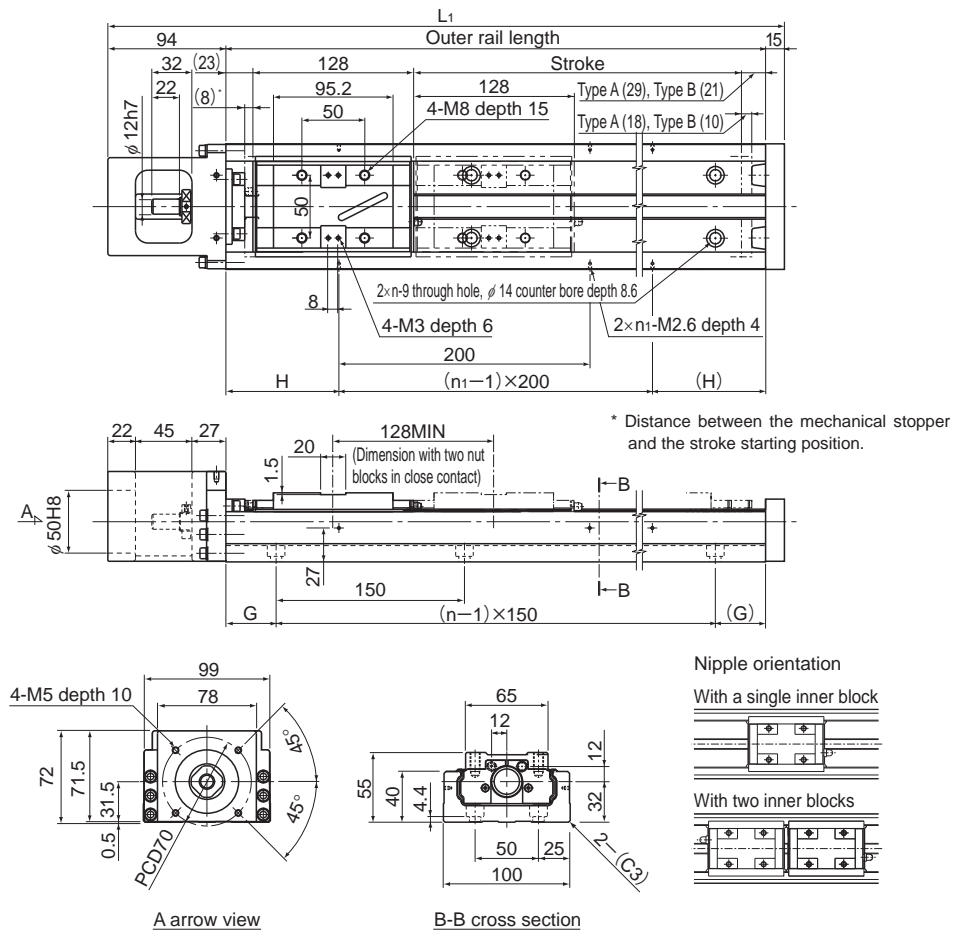

Stroke (mm) (stroke between mechanical stoppers)		Outer rail length (mm)	Overall length $L_1$ (mm)	H (mm)	G (mm)	n	$n_1$	Overall main unit mass (kg)	
Type A	Type B'							Type A	Type B
800(826)	680(698)	980	1089	90	40	7	5	20.2	22
900(926)	780(798)	1080	1189	40	15	8	6	21.9	23.7
1000(1026)	880(898)	1180	1289	90	65	8	6	23.6	25.4
1100(1126)	980(998)	1280	1389	40	40	9	7	25.4	27.2
1200(1226)	1080(1098)	1380	1489	90	15	10	7	27.1	28.9

\*Indicates a value when two inner blocks are in close contact with each other.

## Model KR55 (with a Cover)

Model KR5520A (with a Single Long Nut Block)

Model KR5520B (with Two Long Nut Blocks)

For model number coding, see **A2-106**.

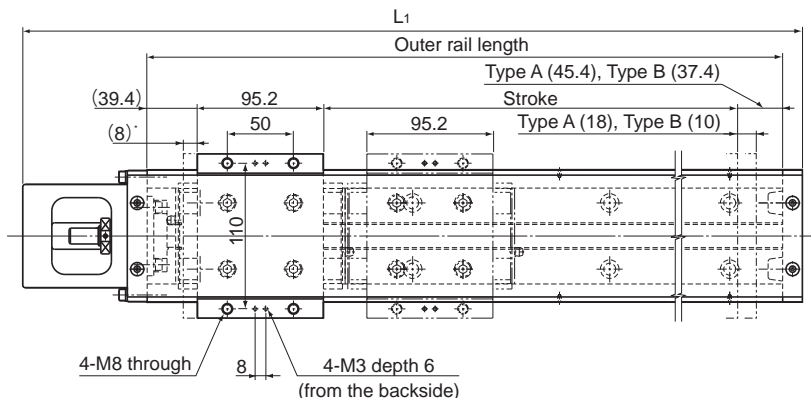

\* Distance between the mechanical stopper and the stroke starting position.

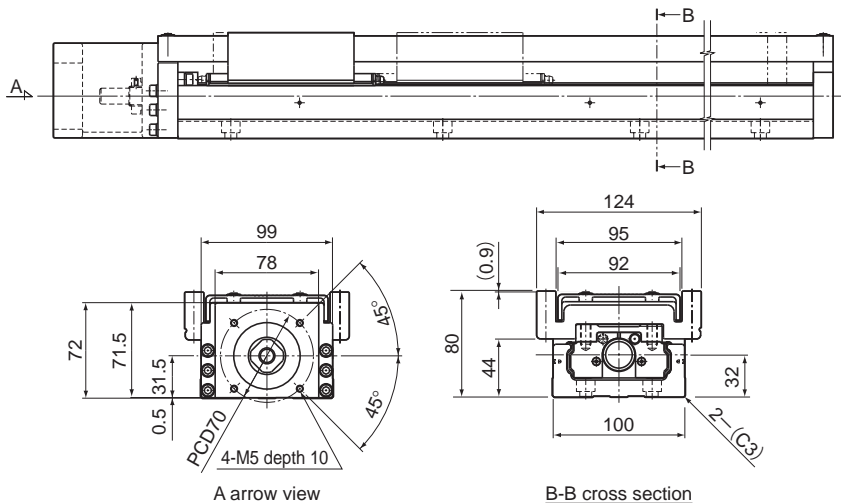

Stroke (mm) (stroke between mechanical stoppers)		Outer rail length (mm)	Overall length L <sub>1</sub> (mm)	Overall main unit mass (kg)	
Type A	Type B*			Type A	Type B
800(826)	680(698)	980	1089	24.1	27.8
900(926)	780(798)	1080	1189	25.9	29.6
1000(1026)	880(898)	1180	1289	27.7	31.4
1100(1126)	980(998)	1280	1389	29.6	33.3
1200(1226)	1080(1098)	1380	1489	31.4	35.1

\*Indicates a value when two inner blocks are in close contact with each other.



# Model KR65 Standard Type

Model KR6525A (with a Single Long Nut Block)

Model KR6525B (with Two Long Nut Blocks)

For model number coding, see **A2-106**.

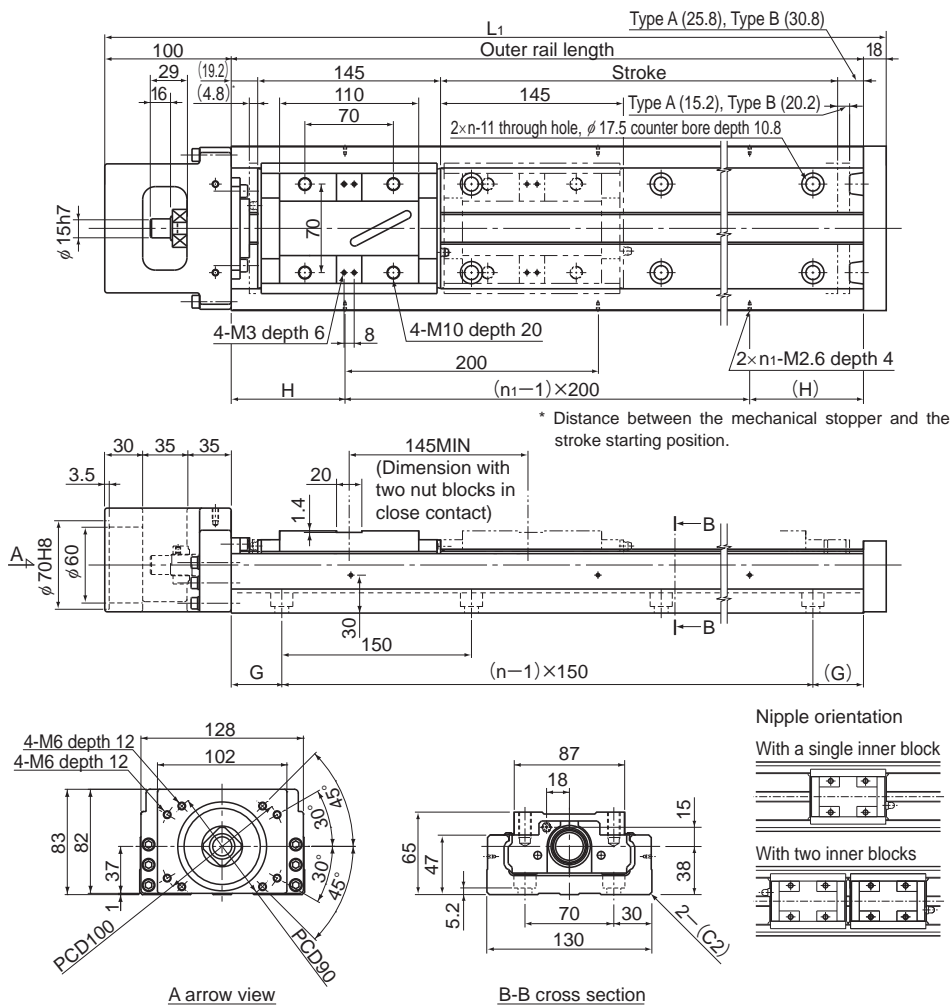

Stroke (mm) (stroke between mechanical stoppers)		Outer rail length (mm)	Overall length $L_1$ (mm)	H (mm)	G (mm)	n	$n_1$	Overall main unit mass (kg)	
Type A	Type B'							Type A	Type B
790(810)	640(665)	980	1098	90	40	7	5	32.2	35.5
990(1010)	840(865)	1180	1298	90	65	8	6	37.6	40.9
1190(1210)	1040(1065)	1380	1498	90	90	9	7	43	46.3
1490(1510)	1340(1365)	1680	1798	40	90	11	9	51.1	54.4

\*Indicates a value when two inner blocks are in close contact with each other.

## Model KR65 (with a Cover)

Model KR6525A (with a Single Long Nut Block)

Model KR6525B (with Two Long Nut Blocks)

For model number coding, see **A2-106**.

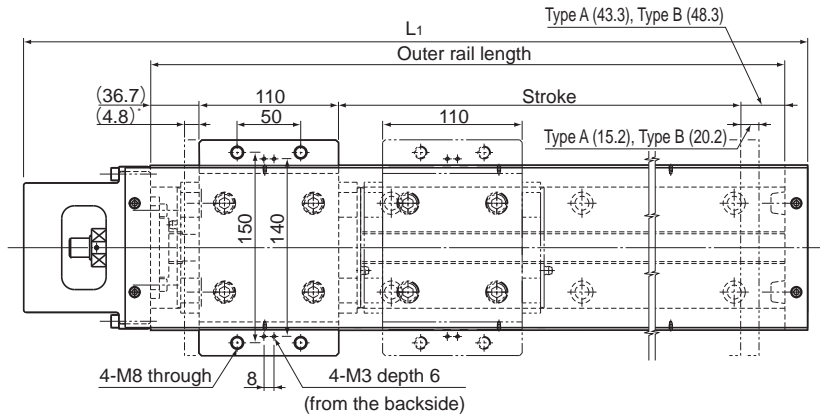

\* Distance between the mechanical stopper and the stroke starting position.

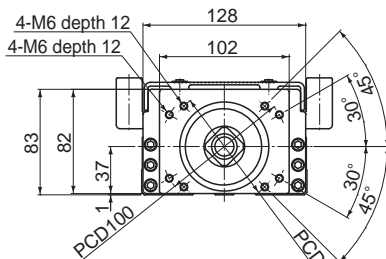
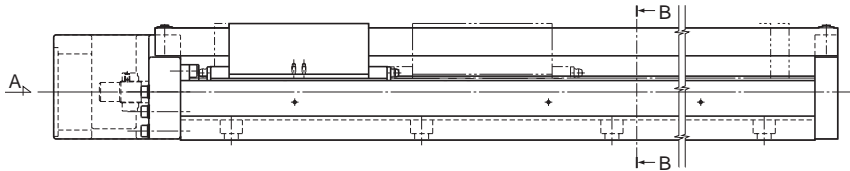

A arrow view

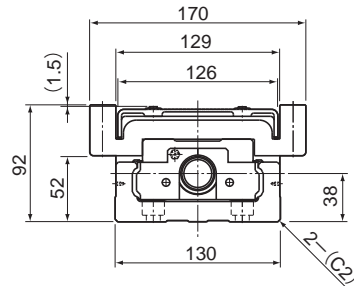

B-B cross section

Stroke (mm) (stroke between mechanical stoppers)		Outer rail length (mm)	Overall length L (mm)	Overall main unit mass (kg)	
Type A	Type B			Type A	Type B
790(810)	640(665)	980	1098	38.6	45.2
990(1010)	840(865)	1180	1298	44.3	50.9
1190(1210)	1040(1065)	1380	1498	50	56.6
1490(1510)	1340(1365)	1680	1798	58.5	65.1

\*Indicates a value when two inner blocks are in close contact with each other.

## Mass of Moving Element

Table13 shows the mass of the inner block and top table of model KR.

Table13 Mass of the Inner Block and Top table of KR

Unit: kg

Model No.	Long nut block types				Short nut block types			
	A/B	Inner block	Top table	Total mass	C/D	Inner block	Top table	Total mass
KR15	Type A	0.04	0.03	0.07	Type C	—	—	—
	Type B	0.08	0.06	0.14	Type D	—	—	—
KR20	Type A	0.08	0.05	0.13	Type C	—	—	—
	Type B	0.16	0.1	0.26	Type D	—	—	—
KR26	Type A	0.19	0.09	0.28	Type C	—	—	—
	Type B	0.38	0.18	0.56	Type D	—	—	—
KR30H	Type A	0.4	0.2	0.6	Type C	0.2	0.1	0.3
	Type B	0.8	0.4	1.2	Type D	0.4	0.2	0.6
KR33	Type A	0.4	0.2	0.6	Type C	0.2	0.1	0.3
	Type B	0.8	0.4	1.2	Type D	0.4	0.2	0.6
KR45H	Type A	1.0	0.4	1.4	Type C	0.6	0.2	0.8
	Type B	2.0	0.8	2.8	Type D	1.2	0.4	1.6
KR46	Type A	1.0	0.4	1.4	Type C	0.6	0.2	0.8
	Type B	2.0	0.8	2.8	Type D	1.2	0.4	1.6
KR55	Type A	1.8	1.9	3.7	Type C	—	—	—
	Type B	3.6	3.8	7.4	Type D	—	—	—
KR65	Type A	3.3	3.3	6.6	Type C	—	—	—
	Type B	6.6	6.6	13.2	Type D	—	—	—