

High Torque Caged Ball Spline



Models SLS, SLS-L and SLF

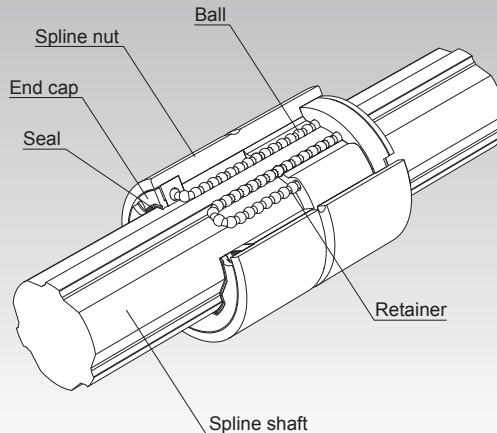

Fig.1 Structure of High Torque Caged Ball Spline

Point of Selection	A3-6
Point of Design	A3-123
Options	A3-126
Model No.	A3-128
Precautions on Use	A3-129
Accessories for Lubrication	A24-1
Mounting Procedure and Maintenance	B3-31
Cross-sectional Characteristics of the Spline Shaft	A3-17
Equivalent factor	A3-27
Clearance in the Rotation Direction	A3-30
Accuracy Standards	A3-35
Maximum Manufacturing Length by Accuracy	A3-121

Structure and Features

The caged-ball technology, developed by bringing together THK's technologies and know-how, is now integrated in the new Ball Spline.

The integration of the ball cage enables the circulating motion of evenly spaced balls and high-speed response to be achieved.

It eliminates collision and mutual friction between balls, and realizes low noise, pleasant running sound and low particle generation. As the grease retention is increased, long-term maintenance-free operation is also achieved.

The high-torque design provides the nut with excellent torsional rigidity. The spline shaft also has enhanced rigidity, thanks to its rounded design.

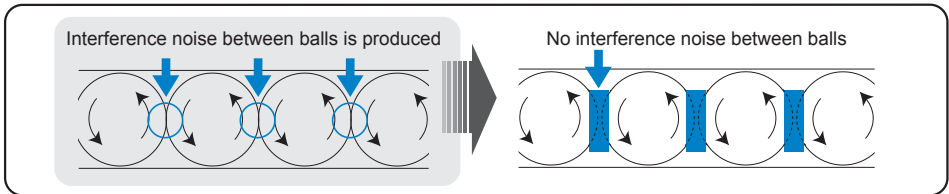

[High-speed Response]

Models SLS/SLF adopt the caged-ball technology to enable the circulating motion of evenly spaced balls to be maintained and high-speed response to be achieved, the cycle time of the machine can be improved.

[Conditions]

Model tested	SLS50
Testing environment	22 to 27.5°C
Stroke	1000mm
Maximum speed	200m/min
Acceleration/deceleration	5G(49m/s ²)
Applied load	Light preload(CL)
Lubricant	THK AFB-LF Grease

Appearance of the test machine
(high-speed durability test)

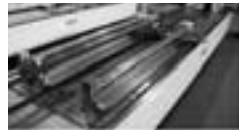

Appearance of the specimen



[Test results]

No anomaly after travelling 10,000 km

[Improvement on the spline shaft's rigidity]

Redesigning the shape of the conventional high torque type spline shaft to be more circular significantly improves its torsion and flexural rigidity.

Unit: mm

Nominal shaft diameter 25	LBS	SLS
Minor diameter ϕd	19.5	21.6
Major diameter ϕD_0	24.5	25.0
Ball center-to-center diameter ϕdp	25	25.2

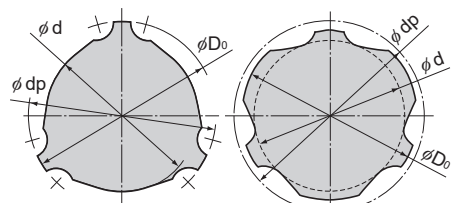

Model LBS

Model SLS

[Low Noise, Pleasant Running Sound and Low Particle Generation]

Models SLS/SLF adopt the caged-ball technology, they eliminate collision and mutual friction between balls, and realize low noise, pleasant running sound and low particle generation.

[Conditions]

Model tested	SLF50/LBF50
Stroke	600mm
Speeds	30,50,100,150m/min
Measuring instrument	Noise level meter

Overview of the test machine

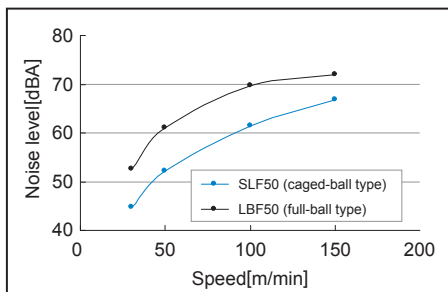
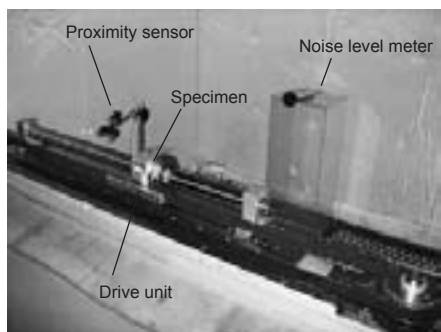

Noise level comparison

[Conditions]

Model tested	SLF50CL+350LP/ LBS50CL+350LP
Maximum speed	30 m/min
Acceleration	2.84 m/s ²
Stroke	200 mm
Amount of air supplied	1 L/200 s
Lubricant	THK AFE-CA Grease
Equipment using the product	Particle counter

Appearance of the test machine

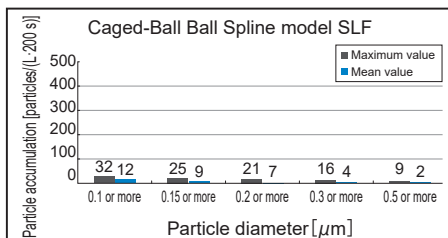
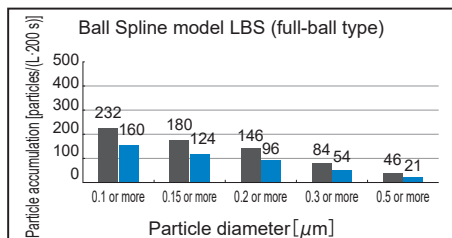
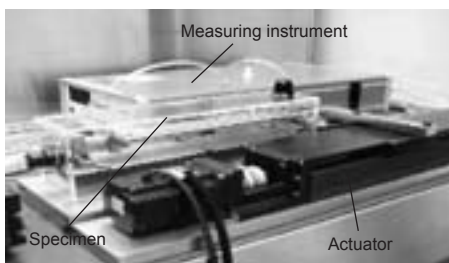

Data on Comparison of Dust Generation

[Long-term Maintenance-free Operation]

Models SLS/SLF adopt the caged-ball technology to substantially increase the grease retention, thus achieving long-term maintenance-free operation.

[Smooth Motion (Small Rolling Fluctuation)]

Models SLS/SLF adopt the caged-ball technology and a new circulation method, thus achieving stable and smooth motion with small rolling fluctuation.

[Conditions]

Model tested	SLF50
Speed	10 mm/s
Applied load	Medium preload(CM)
Lubricant	THK AFB-LF Grease

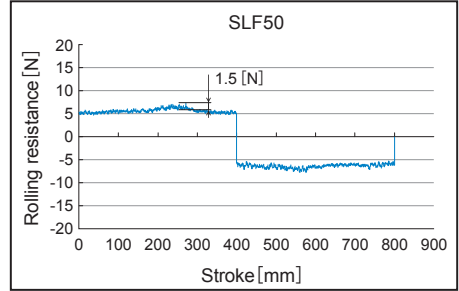

Rolling resistance test

Types and Features

[Types of Spline Nuts]

Cylindrical Type Ball Spline Model SLS (Medium Load Type)

Specification Table⇒ **A3-44**

The circumference of the spline nut is shaped in a straight cylinder.

Using a key, this model can be secured to the housing, or transmit a torque.

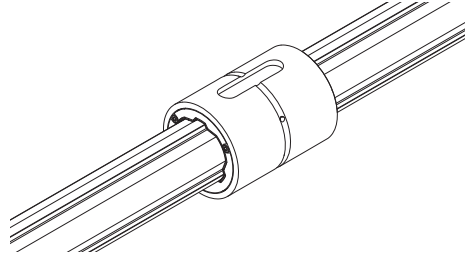

Cylindrical Type Ball Spline Model SLS-L (Heavy Load Type)

Specification Table⇒ **A3-44**

A heavy-load type with the same outer diameter as model SLS and a longer spline nut.

It is optimal in cases where a large torque is applied in a small space, and in cases where an overhang load or moment is applied.

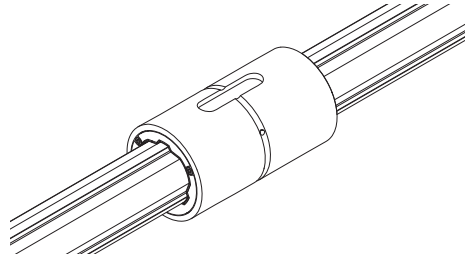

Flanged Type Ball Spline Model SLF

Specification Table⇒ **A3-46**

The housing can be secured with bolts on models equipped with a flange.

This model is easily assembled and can accommodate a shorter housing compared to models with housing secured by a key.

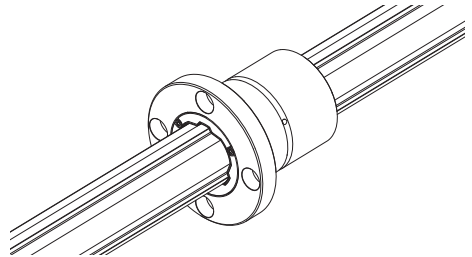

[Types of Spline Shafts]

Precision Solid Spline Shaft (Standard Type)

The spline shaft is cold-drawn and its raceway is precision ground. It is used in combination with a spline nut.



Special Spline Shaft

THK manufactures a spline shaft with thicker ends or thicker middle area through special processing at your request.



Hollow Spline Shaft (Type K)

A drawn, hollow spline shaft is available for requirements such as piping, wiring, air-vent and weight reduction.



Housing Inner-diameter Tolerance

When fitting the spline nut to the housing, transition fit is normally recommended. If the accuracy of the Ball Spline does not need to be very high, clearance fitting is also acceptable.

Table1 Housing Inner-diameter Tolerance

Housing Inner-diameter Tolerance	General conditions	H7
	When clearance needs to be small	J6

Model SLS

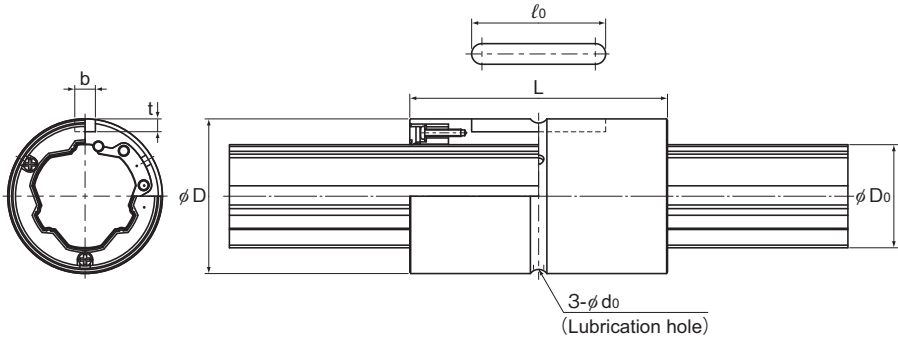

Model No.	Spline nut dimensions							
	Outer diameter		Length		Keyway dimensions			Lubrication hole
	D	Tolerance	L	Tolerance	b H8	t +0.1 0	ℓ_0	d_0
SLS25	37	0	60	0	5	3	33	2
SLS25L			70					
SLS30	45	-0.016	70					
SLS30L			80					
SLS40	60	0	90					
SLS40L			100					
SLS50	75	-0.019	100					
SLS50L			112					
SLS60	90	0	127					
SLS60L			140					
SLS70	100	-0.022	110					
SLS70L			135					
SLS80	120	0	140					
SLS80L			155					
SLS100	140	0	160					
SLS100L			185					
				0	28	9	93	5

Model number coding

2 SLS50 UU CL +700L P K

Model No.

Symbol for clearance
in the rotational direction
(*2)

Symbol for standard hollow spline shaft (*4)
Accuracy symbol (*3)

Contamination protection
accessory symbol (*1)

Overall spline shaft length (*5)
(in mm)

Number of spline nuts on one shaft (no symbol for one nut)

(*1) See **A3-126**. (*2) See **A3-30**. (*3) See **A3-35**. (*4) See **A3-48**. (*5) See **A3-121**.

High Torque Caged Ball Spline

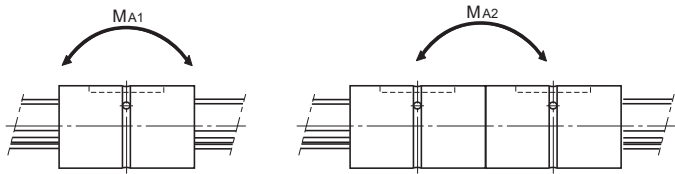

Unit: mm

	Basic torque rating		Basic load rating		Static permissible moment		Mass	
	C _T N·m	C _{0T} N·m	C kN	C ₀ kN	M _{A1} N·m	M _{A2} N·m	Spline Nut kg	Spline shaft kg/m
	219.9 261.9	306.8 394.5	18.2 21.7	22.5 29	136 220	851 1203	0.15 0.18	3.51
	366.5 416.4	513.3 616	25.4 28.9	31.5 37.8	233 330	1341 1803	0.3 0.34	5.05
	818.9 890	1135.4 1277.3	42.8 46.5	52.5 59.1	520 652	2801 3529	0.69 0.79	9.18
	1373.4 1571.2	1783.1 2165.2	57.6 65.9	66.2 80.4	687 996	4156 5349	1.3 1.47	14.45
	2506.7 2723.2	3321 3736.2	87.8 95.3	103 115.8	1452 1820	7733 9570	2.25 2.5	21.23
	2986.3 3708.4	3474.7 4738.2	89.7 111.4	92.5 126.1	1038 1867	6392 10135	2.13 2.71	28.57
	4664.6 5195.3	5477.4 6390.4	122.8 136.8	127.7 148.9	1739 2327	11482 14491	4.22 4.77	37.49
	8922.3 10424.4	10211.6 12764.6	188.2 219.8	190.7 238.4	3155 4816	19118 26463	5.2 6.22	58.97

Model SLF

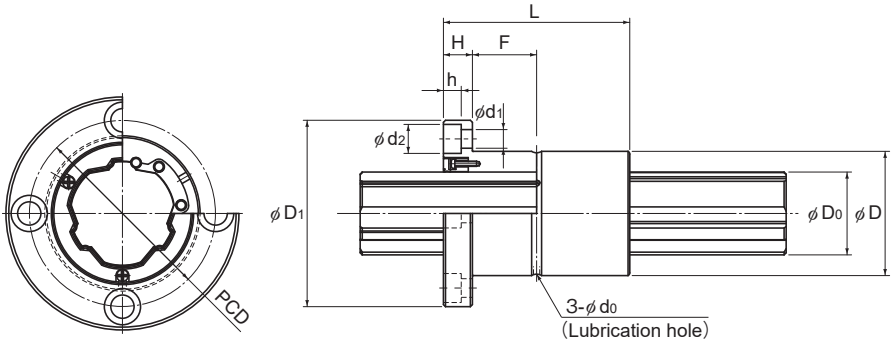

Model No.	Spline nut dimensions									
	Outer diameter		Length		Flange diameter		H	F	Lubrication hole d_o	PCD
	D	Tolerance	L	Tolerance	D_1	Tolerance				
SLF25	37	0	60	0 -0.3	60	0 -0.2	9	21	2	47
SLF30	45	-0.016	70		70		10	25	3	54
SLF40	60	0 -0.019	90		90		14	31	3	72
SLF50	75		100		113	0 -0.3	16	34	4	91
SLF60	90		127		129		18	45.5	4	107
SLF70	100		110		142		20	35	4	117
SLF80	120	0 -0.022	140		168		22	48	5	138
SLF100	140	0 -0.025	160	0 -0.4	195	0 -0.4	25	55	5	162

Model number coding

2 SLF50 UU CL +700L P K

Model No.

Symbol for clearance
in the rotational direction
(*2)

Symbol for standard hollow spline shaft (*4)
Accuracy symbol (*3)

Contamination protection
accessory symbol (*1)

Overall spline shaft length (*5)
(in mm)

Number of spline nuts on one shaft (no symbol for one nut)

(*1) See **A3-126**. (*2) See **A3-30**. (*3) See **A3-35**. (*4) See **A3-48**. (*5) See **A3-121**.

High Torque Caged Ball Spline

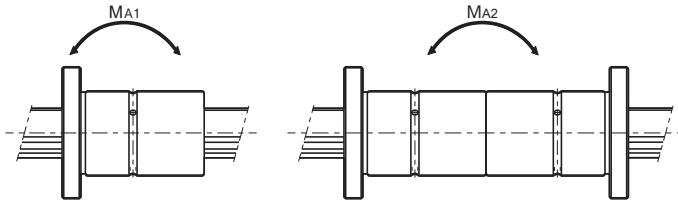

Unit: mm

	Mounting hole $d_1 \times d_2 \times h$	Basic torque rating		Basic load rating		Static permissible moment		Mass	
		C_T N·m	C_{OT} N·m	C kN	C_0 kN	M_{A1} N·m	M_{A2} N·m	Spline Nut kg	Spline shaft kg/m
	5.5×9.5×5.4	219.9	306.8	18.2	22.5	136	851	0.26	3.51
	6.6×11×6.5	366.5	513.3	25.4	31.5	233	1341	0.45	5.05
	9×14×8.6	818.9	1135.4	42.8	52.5	520	2801	1.06	9.18
	11×17.5×11	1373.4	1783.1	57.6	66.2	687	4156	1.9	14.45
	11×17.5×11	2506.7	3321	87.8	103	1452	7733	3.08	21.23
	14×20×13	2986.3	3474.7	89.7	92.5	1038	6392	3.25	28.57
	16×23×15.2	4664.6	5477.4	122.8	127.7	1739	11482	5.82	37.49
	18×26×17.5	8922.3	10211.6	188.2	190.7	3155	19118	7.66	58.97

Spline Shaft

Spline shafts are divided in shape into precision solid spline shaft, special spline shaft and hollow spline shaft (type K), as described on **A3-43**.

Since production of a spline shaft with a specific shape is performed at your request, provide a drawing of the desired shaft shape when asking an estimate or placing an order.

[Sectional Shape of the Spline Shaft]

Table2 shows the sectional shape of a spline shaft. If the spline shaft ends need to be cylindrical, the minor diameter (ϕd) value should not be exceeded if possible.

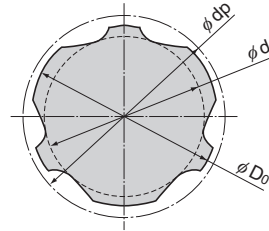

Table2 Sectional Shape of the Spline Shaft

Unit: mm

Nominal shaft diameter	25	30	40	50	60	70	80	100
Minor diameter ϕd	21.6	25.8	35.2	44.4	54	62.8	71.3	90
Major diameter $\phi D_0 h7$	25	30	40	50	60	70	80	100
Ball center-to-center diameter ϕdp	25.2	30.2	40.6	50.6	61	71	80.8	101.2
Mass(kg/m)	3.51	5.05	9.18	14.45	21.23	28.57	37.49	58.97

*The minor diameter ϕd must be a value at which no groove is left after machining.

[Hole Shape of the Standard Hollow Type Spline Shaft]

Table3 shows the hole shape of the standard hollow type spline shaft. Use this table when a requirement such as piping, wiring, air-vent or weight reduction needs to be met.

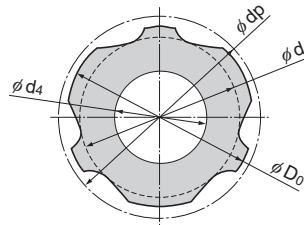

Table3 Sectional Shape of the Standard Hollow Type Spline Shaft

Unit: mm

Nominal shaft diameter	25	30	40	50	60	70	80	100
Minor diameter ϕd	21.6	25.8	35.2	44.4	54	62.8	71.3	90
Major diameter $\phi D_0 h7$	25	30	40	50	60	70	80	100
Ball center-to-center diameter ϕdp	25.2	30.2	40.6	50.6	61	71	80.8	101.2
Hole diameter(ϕd_4)	12	16	22	25	32	—	52.5	67.5
Mass(kg/m)	2.62	3.47	6.19	10.59	14.9	—	20.48	30.85

*The minor diameter ϕd must be a value at which no groove is left after machining.

[Chamfering of the Spline Shaft Ends]

To facilitate the insertion of the spline shaft into a spline nut, the shaft ends are normally chamfered with the dimensions indicated below unless otherwise specified.

The ends are chamfered whether they are used, such as with stepped, tapped, or drilled ends, or not used, such as with cantilevered supports.

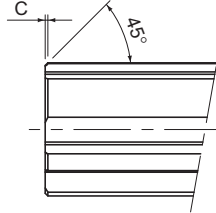

SLS25 to 100

Table 4 Chamfer Dimensions of Spline Shaft Ends

Unit: mm

Nominal shaft diameter	25	30	40	50	60	70	80	100
Chamfer C	0.5	0.5	1	1	2	2	2	2

[Length of the Incomplete Area of a Special Spline Shaft]

If any part of the spline shaft is thicker than the minor diameter (ϕd), an area with incomplete splines is required to secure a recess for grinding. The relationship between the flange diameter (ϕdf) and the length of incomplete splines (S) is shown in Table 5.

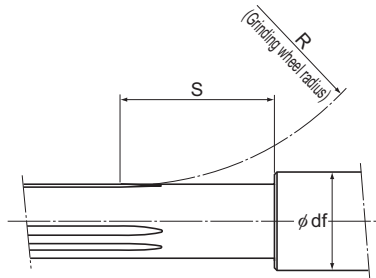

Table 5 Length of Incomplete Spline Area: S

Unit: mm

Flange diameter ϕdf	Nominal shaft diameter										
	25	30	35	40	50	60	80	100	120	140	160
25	41	54	63	72	—	—	—	—	—	—	—
30	—	44	56	65	80	—	—	—	—	—	—
40	—	—	—	46	66	81	104	—	—	—	—
50	—	—	—	—	48	69	94	114	—	—	—
60	—	—	—	—	—	49	83	105	123	—	—
70	—	—	—	—	—	—	70	96	116	131	—
80	—	—	—	—	—	—	55	86	108	125	—
100	—	—	—	—	—	—	—	58	88	109	126

Accessories

Ball Spline models SLS and SLS-L are provided with a standard key as indicated in Table6.

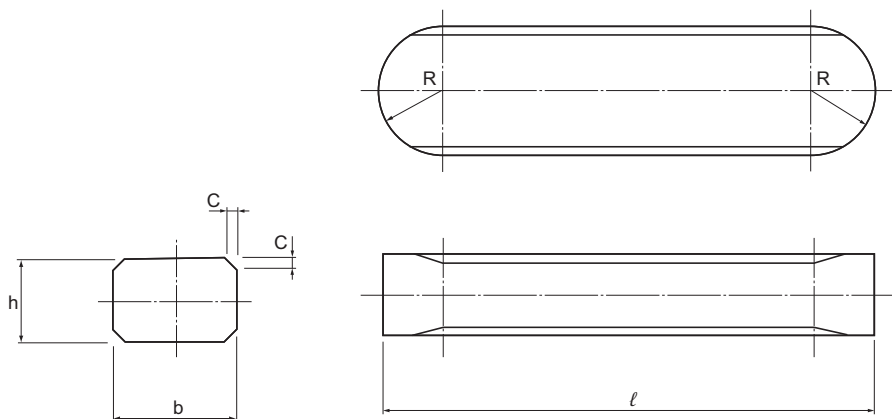

Table6 Standard Keys for Models SLS and SLS-L

Unit: mm

Nominal shaft diameter	Width		Height		Length		R	C
	b	Tolerance(p7)	h	Tolerance(h9)	ℓ	Tolerance(h12)		
SLS 25 SLS 25L	5	+0.024 +0.012	5	0 -0.030	33	0 -0.250	2.5	0.5
SLS 30 SLS 30L	7	+0.030 +0.015	7	0 -0.036	41	0 -0.300	3.5	
SLS 40 SLS 40L	10		8		55		5	0.8
SLS 50 SLS 50L	15	10	60		7.5			
SLS 60 SLS 60L	18	+0.036 +0.018	12	0 -0.043	68	0 -0.350	9	1.2
SLS 70 SLS 70L					80		80	
SLS 80 SLS 80L	20	+0.043 +0.022	13					
SLS 100 SLS 100L	28	18	18		93		0 -0.400	

High Torque Caged Ball Spline

Ball Spline