

Medium Torque Type Ball Spline

Models LT, LF, LT-X, LF-X, LFK-X, and LFH-X

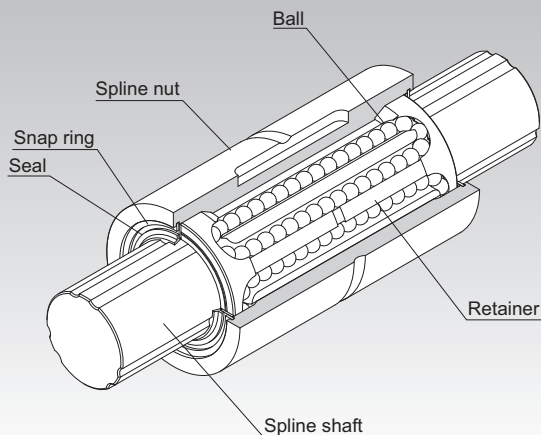

Fig.1 Structure of Medium Torque Type Ball Spline Model LT

Point of Selection **A3-6**

Point of Design **A3-123**

Options **A3-126**

Model No. **A3-128**

Precautions on Use **A3-129**

Accessories for Lubrication **A24-1**

Mounting Procedure and Maintenance **B3-31**

Cross-sectional Characteristics of the Spline Shaft **A3-17**

Equivalent factor **A3-27**

Clearance in the Rotation Direction **A3-30**

Accuracy Standards **A3-35**

Maximum Manufacturing Length by Accuracy **A3-121**

Structure and Features

With the medium torque type Ball Spline, the spline shaft has two to three crests on the circumference, and along both sides of each crest, two rows of balls (four or six rows in total) are arranged to hold the crest so that a reasonable preload is applied.

The rows of balls are held in a special resin retainer incorporated in the spline nut so that they smoothly roll and circulate. With this design, balls will not fall even if the nut is removed from the spline shaft.

[Large Load Capacity]

The raceways are formed into circular-arc grooves approximate to the ball curvature and ensure angular contact. Thus, this model has a large load capacity in the radial and torque directions.

[No Angular Backlash]

Two rows of balls facing one another hold a crest, formed on the circumference of the spline nut, at a contact angle of 20° to provide a preload in an angular-contact structure. This eliminates an angular backlash in the rotational direction and increases the rigidity.

[High Rigidity]

Since the contact angle is large and an appropriate preload is given, high rigidity against torque and moment is achieved.

[Ball Retaining Type]

Use of a retainer prevents the balls from falling even if the spline shaft is pulled out of the spline nut. (except for models LT4 and 5)

Types and Features

[Types of Spline Nuts]

Cylindrical Type Ball Spline Model LT

Specification Table⇒ **A3-80**

The most compact type with a straight cylindrical spline nut. When transmitting a torque, a key is driven into the body.

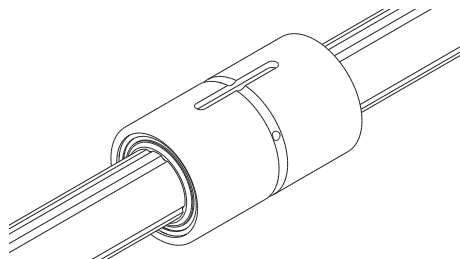

Flanged Type Ball Spline Model LF

Specification Table⇒ **A3-82**

The spline nut can be attached to the housing via the flange, making assembly simple.

It is optimal for locations where the housing may be deformed if a keyway is machined on its surface, and where the housing width is small.

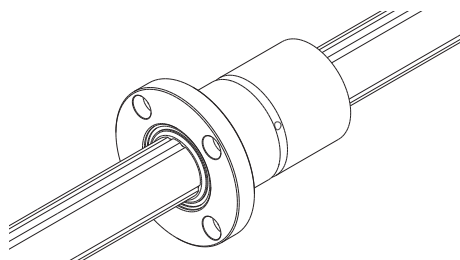

Model LT-X Compact Ball Spline

Specification Table⇒ **A3-84**

The nut is more compact than that of the current Model LT thanks to the new circulating pathways.

The outer diameter of the nut is the same as that of the linear bushing.

The Model LT-XL is suitable for moment loads, torque, and overhung loads that exceed those tolerated by the Model LT-X.

Models LT4X to 6X are made of stainless steel, which has high corrosion resistance.

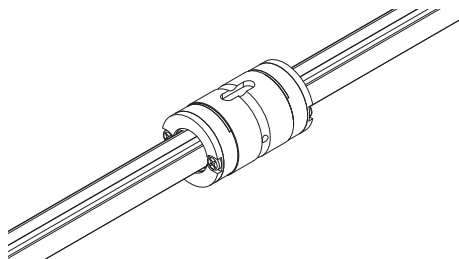

Model LF-X Compact Ball Spline

Specification Table⇒ **A3-86**

The nut is more compact than that of the current Model LF thanks to the new circulating pathways.

The outer diameter of the nut is the same as that of the linear bushing.

The Model LF-XL is suitable for moment loads, torque, and overhung loads that exceed those tolerated by the Model LF-X.

Models LF4X to 6X are made of stainless steel, which has high corrosion resistance.

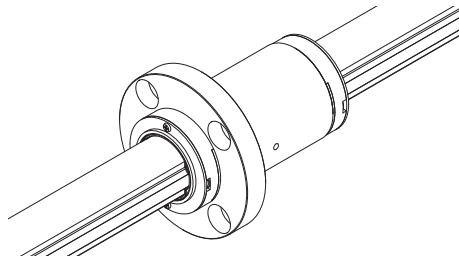

Model LFK-X Compact Ball Spline

Specification Table⇒ **A3-88**

The flange is similar to the Model LF-X, but flattened in four places. Compared to models with round flanges, its core height is lower, and it allows for more compact designs.

The Model LFK-XL is suitable for moment loads or torque and overhang loads that exceed those tolerated by the Model LFK-X.

Models LFK5X and 6X are made of stainless steel, which has high corrosion resistance.

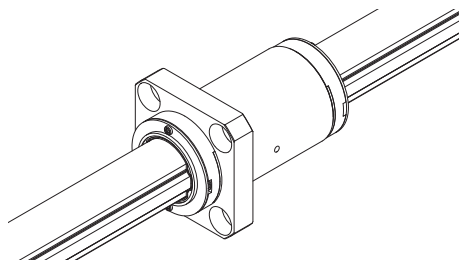

Model LFH-X Compact Ball Spline

Specification Table⇒ **A3-90**

The flange is similar to the Model LF-X, but flattened in two places. Compared to models with square flanges, its core height is lower, and it allows for a lighter overall design.

The Model LFH-XL is suitable for moment loads or torque and overhang loads that exceed those tolerated by the Model LFH-X.

Models LFH5X and 6X are made of stainless steel, which has high corrosion resistance.

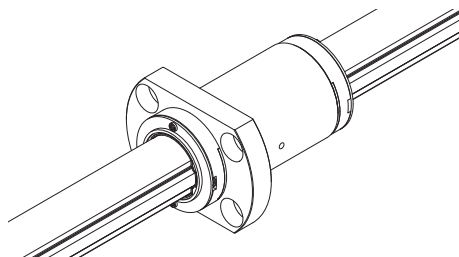

[Types of Spline Shafts]

Precision Solid Spline Shaft (Standard Type)

The raceway of the spline shaft is precision ground. It is used in combination with a spline nut.

**Special Spline Shaft**

THK manufactures a spline shaft with thicker ends or thicker middle area through special processing at your request.

**Hollow Spline Shaft (Type K)**

A drawn, hollow spline shaft is available for requirements such as piping, wiring, air-vent and weight reduction.



Thick

Hollow Spline Shaft (Type N)

A drawn, hollow spline shaft is available for requirements such as piping, wiring, air-vent and weight reduction.



Thin

Housing Inner-diameter Tolerance

When fitting the spline nut to the housing, transition fit is normally recommended. If the accuracy of the Ball Spline does not need to be very high, clearance fitting is also acceptable.

Table1 Housing Inner-diameter Tolerance

Housing Inner-diameter Tolerance	General conditions	H7
	When clearance needs to be small	J6

Model LT

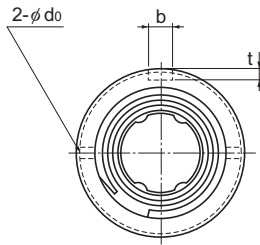

Models LT4 to 13

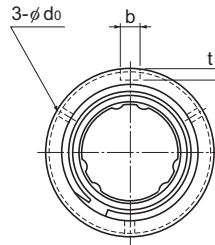

Models LT16 to 100

Model No.	Spline nut dimensions								
	Outer diameter		Length		b H8	Keyway dimensions		r	Lubrication hole d _o
	D	Tolerance	L	Tolerance		t +0.1 0	ℓ _o		
Note) LT 4	10	⁰ -0.009	16	0 -0.2	2	1.2	6	0.5	—
Note) LT 5	12	0 -0.011	20		2.5	1.2	8	0.5	—
LT 6	14		25		2.5	1.2	10.5	0.5	1
LT 8	16		25		2.5	1.2	10.5	0.5	1.5
LT 10	21		33		3	1.5	13	0.5	1.5
LT 13	24	⁰ -0.013	36	3	1.5	15	0.5	1.5	
○ LT 16	31	0 -0.016	50	0 -0.3	3.5	2	17.5	0.5	2
○ LT 20	35		63		4	2.5	29	0.5	2
○ LT 25	42		71		4	2.5	36	0.5	3
○ LT 30	47		80		4	2.5	42	0.5	3
○ LT 40	64		0		100	6	3.5	52	0.5
○ LT 50	80	-0.019	125	8	4	58	1	4	
○ LT 60	90	0	140	12	5	67	1	5	
○ LT 80	120	-0.022	160	16	6	76	2	5	
○ LT 100	150	⁰ -0.025	185	0 -0.4	20	7	110	2.5	5

Note) Models LT4 and 5 do not have a retainer. Do not remove the shaft from the spline nut. (It will cause balls to fall off.)

○: indicates model numbers for which high temperature types are available (with metal retainer, service temperature: up to 100°C).

(Example) LT20 A CL +500L H

High temperature symbol

Model number coding

2 **LT30** **UU** **CL** **+500L** **H** **K**

Model No.

Symbol for clearance
in the rotational direction
(*2)

Accuracy symbol
(*3)

Symbol for spline shaft (*4)

Number of spline nuts
on one shaft
(no symbol for one nut)

Contamination protection
accessory symbol
(*1)

Overall spline shaft length (*5)
(in mm)

(*1) See **A3-126**. (*2) See **A3-30**. (*3) See **A3-35**. (*4) See **A3-93**. (*5) See **A3-121**.

Medium Torque Type Ball Spline

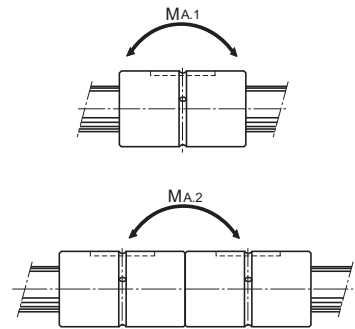
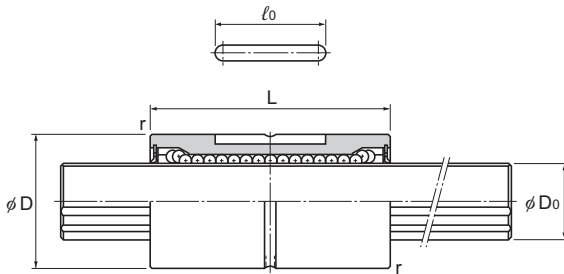

Unit: mm

	Spline shaft diameter D_0 h7	Rows of balls	Basic torque rating		Basic Load Rating		Static permissible moment		Mass	
			C_T N·m	C_{OT} N·m	C kN	C_0 kN	M_{A1}^{**} N·m	M_{A2}^{**} N·m	Spline Nut g	Spline shaft kg/m
	4	4	0.59	0.78	0.44	0.61	0.88	6.4	5.2	0.1
	5	4	0.88	1.37	0.66	0.88	1.5	11.6	9.1	0.15
	6	4	0.98	1.96	1.18	2.16	4.9	36.3	17	0.23
	8	4	1.96	2.94	1.47	2.55	5.9	44.1	18	0.4
	10	4	3.92	7.84	2.84	4.9	15.7	98	50	0.62
	13	4	5.88	10.8	3.53	5.78	19.6	138	55	1.1
	16	6	31.4	34.3	7.06	12.6	67.6	393	165	1.6
	20	6	56.9	55.9	10.2	17.8	118	700	225	2.5
	25	6	105	103	15.2	25.8	210	1140	335	3.9
	30	6	171	148	20.5	34	290	1710	375	5.6
	40	6	419	377	37.8	60.5	687	3760	1000	9.9
	50	6	842	769	60.9	94.5	1340	7350	1950	15.5
	60	6	1220	1040	73.5	111.7	1600	9990	2500	22.3
	80	6	2310	1920	104.9	154.8	2510	16000	4680	39.6
	100	6	3730	3010	136.2	195	3400	24000	9550	61.8

Note) M_{A1} indicates the permissible moment value in the axial direction when a single spline nut is used, as shown in the figure above.

M_{A2} indicates the permissible moment value in the axial direction when two spline nuts in close contact with each other are used, as shown in the figure above.

For details on the maximum lengths of ball spline shafts by accuracy, please see **A3-121**.

Model LF

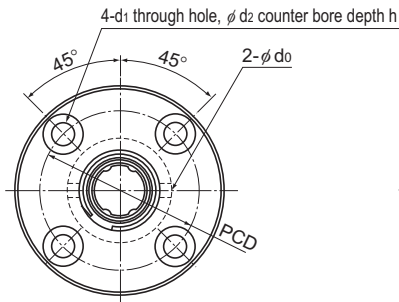

Models LF6 to 13

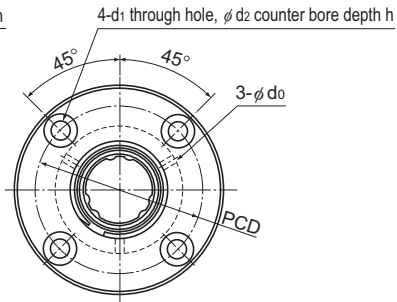

Models LF16 to 60

Model No.	Spline nut dimensions														
	Outer diameter		Length		Flange diameter		H	F	C	r	Lubrication hole d ₀	PCD	Mounting hole d ₁ ×d ₂ ×h		
	D	Tolerance	L	Tolerance	D ₁	Tolerance									
LF 6	14	0	25	0 -0.2	30	0 -0.2	5	7.5	0.5	0.5	1.5	22	3.4×6.5×3.3		
LF 8	16	-0.011	25		32		5	7.5	0.5	0.5	1.5	24	3.4×6.5×3.3		
LF 10	21	0 -0.013	33		42		6	10.5	0.5	0.5	1.5	32	4.5×8×4.4		
LF 13	24		36	44	7		11	0.5	0.5	1.5	33	4.5×8×4.4			
○ LF 16	31	0 -0.016	50	0 -0.3	51		0 -0.2	7	18	0.5	0.5	2	40	4.5×8×4.4	
○ LF 20	35		63		58			9	22.5	0.5	0.5	2	45	5.5×9.5×5.4	
○ LF 25	42		71		65			9	26.5	0.5	0.5	3	52	5.5×9.5×5.4	
○ LF 30	47	80	75	10	30			0.5	0.5	3	60	6.6×11×6.5			
○ LF 40	64	0	100	0 -0.3	100			0 -0.2	14	36	1	0.5	4	82	9×14×8.6
○ LF 50	80	-0.019	125		124				16	46.5	1	1	4	102	11×17.5×11
○ LF 60	90	0 -0.022	140		0 -0.4	134			18	52	1	1	5	112	11×17.5×11

Note) ○: indicates model numbers for which high temperature types are available (with metal retainer; service temperature: up to 100°C).

(Example) LF30 A CL+700L H

High temperature symbol

Model number coding

2 LF20 UU CM +400L P N

2: Model No.
 LF20: Number of spline nuts on one shaft (no symbol for one nut) (*1)
 UU: Symbol for clearance in the rotational direction (*2)
 CM: Contamination protection accessory symbol
 +400L: Overall spline shaft length (in mm) (*3)
 P: Accuracy symbol (*3)
 N: Symbol for spline shaft (*4)

(*1) See **A3-126**. (*2) See **A3-30**. (*3) See **A3-35**. (*4) See **A3-93**. (*5) See **A3-121**.

Medium Torque Type Ball Spline

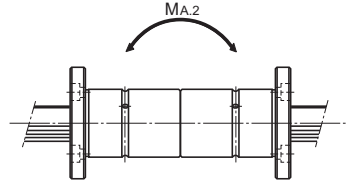
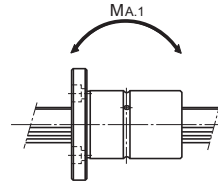
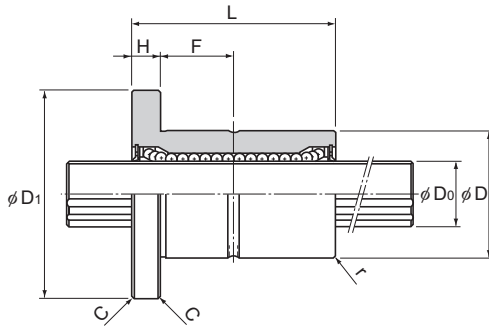

Unit: mm

Ball Spline

	Spline shaft diameter D_0 h7	Rows of balls	Basic torque rating		Basic load rating		Static permissible moment		Mass	
			C_T N·m	C_{0T} N·m	C kN	C_0 kN	M_{A1}^{**} N·m	M_{A2}^{**} N·m	Spline Nut g	Spline shaft kg/m
	6	4	0.98	1.96	1.18	2.16	4.9	36.3	35	0.23
	8	4	1.96	2.94	1.47	2.55	5.9	44.1	37	0.4
	10	4	3.92	7.84	2.84	4.9	15.7	98	90	0.62
	13	4	5.88	10.8	3.53	5.78	19.6	138	110	1.1
	16	6	31.4	34.3	7.06	12.6	67.6	393	230	1.6
	20	6	56.9	55.9	10.2	17.8	118	700	330	2.5
	25	6	105	103	15.2	25.8	210	1140	455	3.9
	30	6	171	148	20.5	34	290	1710	565	5.6
	40	6	419	377	37.8	60.5	687	3760	1460	9.9
	50	6	842	769	60.9	94.5	1340	7350	2760	15.5
	60	6	1220	1040	73.5	111.7	1600	9990	3490	22.3

Note) M_{A1}^{**} indicates the permissible moment value in the axial direction when a single spline nut is used, as shown in the figure above.

M_{A2}^{**} indicates the permissible moment value in the axial direction when two spline nuts in close contact with each other are used, as shown in the figure above.

For details on the maximum lengths of ball spline shafts by accuracy, please see **A3-121**.

Model LT-X

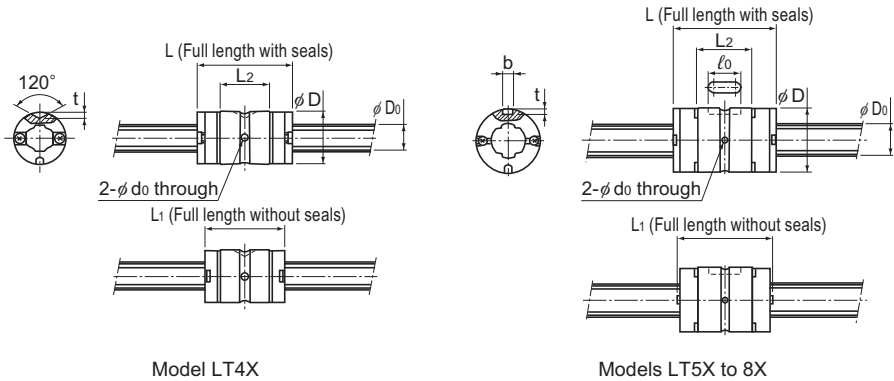

Model LT4X

Models LT5X to 8X

Model No.	Spline shaft diameter		Spline nut dimensions							
	D ₀ h7	Outer diameter		Length			Keyway dimensions			Lubrication hole
		D	Tolerance	L (With seals)	L ₁ (Without seals)	L ₂	b H8	t	l ₀	d ₀
LT 4X	4	8	$\begin{matrix} 0 \\ -0.009 \end{matrix}$	14.4	12	7.5	—	1	—	1
LT 5X LT 5XL	5	10	$\begin{matrix} 0 \\ -0.009 \end{matrix}$	15 26	13.6 24.6	7.3 18.3	2	1.2	4.7	1
LT 6X LT 6XL	6	12	$\begin{matrix} 0 \\ -0.011 \end{matrix}$	19 30	17.6 28.6	10.2 21.2	2	1.2	6	1
LT 8X LT 8XL	8	15	$\begin{matrix} 0 \\ -0.011 \end{matrix}$	25 40	23.8 38.8	14.6 29.6	2.5	1.2	8	1.5
LT 10X	10	19	$\begin{matrix} 0 \\ -0.013 \end{matrix}$	33	30.8	23.9	3	1.5	13	1.5
LT 13X	13	23	$\begin{matrix} 0 \\ -0.013 \end{matrix}$	36	32.4	24	3	1.5	15	1.5
LT 16X	16	28	$\begin{matrix} 0 \\ -0.013 \end{matrix}$	50	46.4	35.5	3.5	2	17.5	2
LT 20X	20	32	$\begin{matrix} 0 \\ -0.016 \end{matrix}$	63	59	47.4	4	2.5	29	2
LT 25X	25	40	$\begin{matrix} 0 \\ -0.016 \end{matrix}$	71	67	52.6	4	2.5	36	3
LT 30X	30	45	$\begin{matrix} 0 \\ -0.016 \end{matrix}$	80	75.6	59.6	4	2.5	42	3

Model number coding

2 LT20X UU CL +700L P K

Model No.

Number of spline nuts
on one shaft
(no symbol for one nut)

Symbol for clearance
in the rotational direction

(⁽²⁾)
Contamination protection
accessory symbol (⁽¹⁾)

Accuracy
symbol (⁽³⁾)

Overall spline shaft length (⁽⁵⁾)
(in mm)

Symbol for spline shaft (⁽⁴⁾)

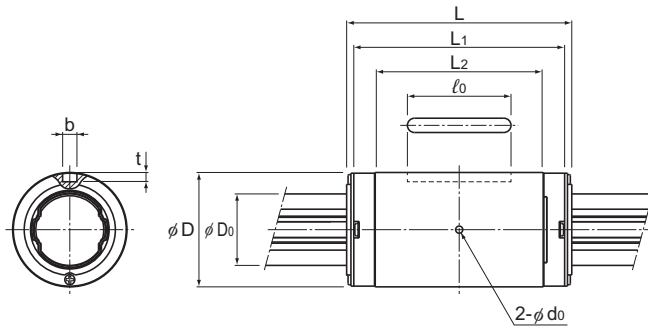

(⁽¹⁾) See **A3-126**. (⁽²⁾) See **A3-30**. (⁽³⁾) See **A3-35**. (⁽⁴⁾) See **A3-93**. (⁽⁵⁾) See **A3-121**.

Medium Torque Type Ball Spline



Models LT10X to 30X

Unit: mm

	Basic torque rating		Basic load rating		Static permissible moment			Mass	
	C_T N·m	C_{OT} N·m	C kN	C_0 kN	M_{A1}  N·m	M_{A2} (With seal)  N·m	M_{A2} (Without seal)  N·m	Spline Nut g	Spline shaft kg/m
	0.49	0.82	0.42	0.7	0.84	6.2	5	2.2	0.1
	0.82 1.59	1.25 3.2	0.56 1.09	0.85 2.19	1.04 6.11	8.2 35.5	6.6 28.4	3.3 8	0.15
	1.73 2.81	2.77 5.54	0.98 1.6	1.58 3.15	2.85 10.6	19 59.8	15.2 47.8	6.6 13.3	0.21
	6 10.1	9.23 19.5	1.39 2.35	2.15 4.53	5.13 21.1	34.3 110.9	27.4 88.7	14.3 24.3	0.38
	9.41	17.3	2.94	5.4	21.5	114	104	30	0.59
	17.1	28.7	4.16	6.96	28.9	164	149	40	1.01
	42.9	68.6	8.4	13.4	77.4	419	381	81	1.52
	66.4	117	10.5	18.6	144	735	669	130	2.41
	125	207	15.9	26.2	230	1183	1077	235	3.71
	196	319	20.8	34	335	1714	1560	295	5.37

Note) The mass of the spline nut does not include the seal.
Please check the spline shaft strength tests (**A3-12**) before use.

Model LF-X

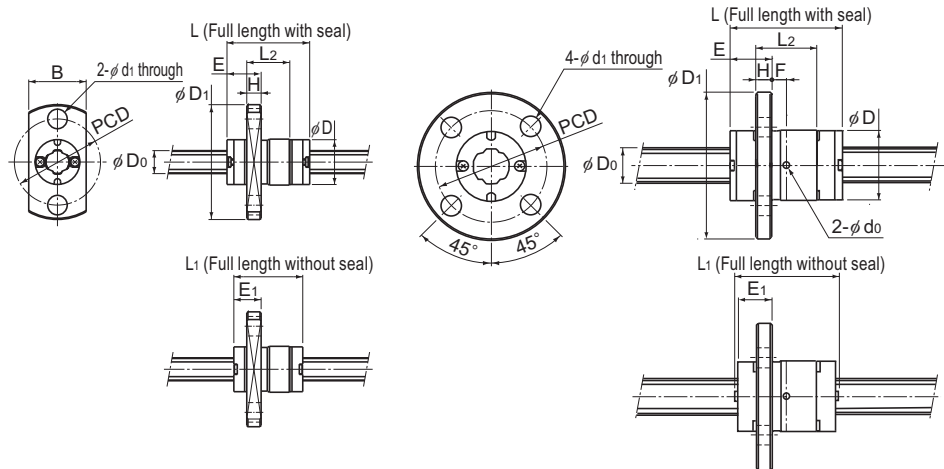

Model LF4X

Models LF5X to 8X

Model No.	Spline shaft diameter		Spline nut dimensions											
	D ₀ h7	Outer diameter		Length			Flange Outer Diameter		H	F	E	E ₁	Lubrication hole d ₀	PCD
		D	Tolerance	L (With seal)	L ₁ (Without seal)	L ₂	D ₁	B						
LF 4X	4	8	⁰ _{-0.009}	14.4	12	7.5	20	10	2.5	—	5.95	4.75	—	15
LF 5X LF 5XL	5	10	⁰ _{-0.009}	15 26	13.6 24.6	7.3 18.3	23	—	2.7	— 6.5	6.55	5.35	— 1	17
LF 6X LF 6XL	6	12	⁰ _{-0.011}	19 30	17.6 28.6	10.2 21.2	25	—	2.7	2.4 7.9	7.1	5.9	1	19
LF 8X LF 8XL	8	15	⁰ _{-0.011}	25 40	23.8 38.8	14.6 29.6	28	—	3.8	3.5 11	9	7.5	1.5	22
LF 10X	10	19	⁰ _{-0.013}	33	30.8	23.9	38	—	6	5.95	10.55	9.45	1.5	28
LF 13X	13	23	⁰ _{-0.013}	36	32.4	24	43	—	6	6	12	10.2	1.5	33
LF 16X	16	28	⁰ _{-0.013}	50	46.4	35.5	48	—	6	11.7	13.3	11.5	2	38
LF 20X	20	32	⁰ _{-0.016}	63	59	47.4	54	—	8	15.7	15.8	13.8	2	43
LF 25X	25	40	⁰ _{-0.016}	71	67	52.6	62	—	8	18.3	17.2	15.2	3	51
LF 30X	30	45	⁰ _{-0.016}	80	75.6	59.6	74	—	10	19.8	20.2	18	3	60

Model number coding

2 LF20X UU CL +700L P K

Model No.

Number of spline nuts
on one shaft
(no symbol for one nut)

Symbol for clearance
in the rotational direction
(*2)

Contamination protection
accessory symbol (*1)

Accuracy
symbol (*3)

Overall spline shaft length (*5)
(in mm)

Symbol for spline shaft (*4)

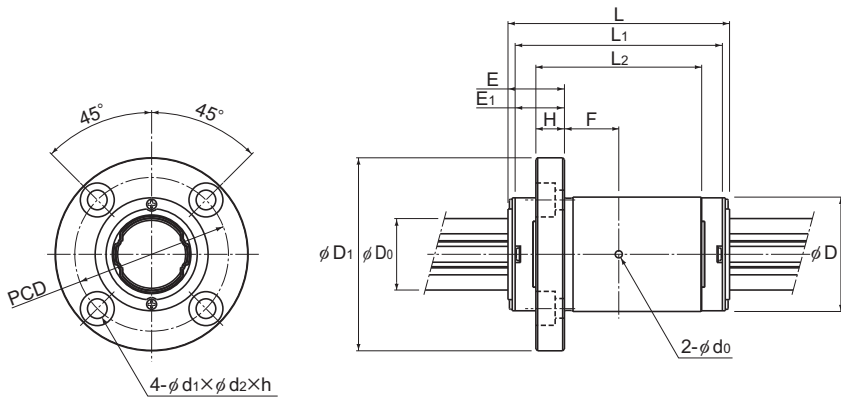

(*1) See **A3-126**. (*2) See **A3-30**. (*3) See **A3-35**. (*4) See **A3-93**. (*5) See **A3-121**.

Medium Torque Type Ball Spline



Models LF10X to 30X

Unit: mm

Mounting hole		Basic torque rating		Basic load rating		Static permissible moment			Mass	
		C_T N·m	C_{OT} N·m	C kN	C_0 kN	M_{A1}  N·m	M_{A2} (With seal)  N·m	M_{A2} (Without seal)  N·m	Spline Nut g	Spline shaft kg/m
$d_1 \times d_2 \times h$	3.4 through	0.49	0.82	0.42	0.7	0.84	6.2	5	4.7	0.1
	3.4 through	0.82 1.59	1.25 3.2	0.56 1.09	0.85 2.19	1.04 6.11	8.2 35.5	6.6 28.4	9.9 14.6	0.15
3.4 through	3.4 through	1.73 2.81	2.77 5.54	0.98 1.6	1.58 3.15	2.85 10.6	19 59.8	15.2 47.8	13.8 20.5	0.21
	3.4 through	6 10.1	9.23 19.5	1.39 2.35	2.15 4.53	5.13 21.1	34.3 110.9	27.4 88.7	26.5 36.5	0.38
4.5×8×4.4	9.41	17.3	2.94	5.4	21.5	114	104	66	0.59	
4.5×8×4.4	17.1	28.7	4.16	6.96	28.9	164	149	82	1.01	
4.5×8×4.4	42.9	68.6	8.4	13.4	77.4	419	381	131	1.52	
5.5×9.5×5.4	66.4	117	10.5	18.6	144	735	669	212	2.41	
5.5×9.5×5.4	125	207	15.9	26.2	230	1183	1077	335	3.71	
6.6×11×6.5	196	319	20.8	34	335	1714	1560	489	5.37	

Note) The mass of the spline nut does not include the seal.
Please check the spline shaft strength tests (A3-12) before use.

Model LFK-X

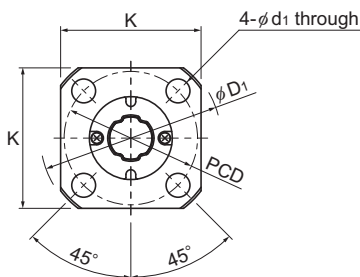

Models LFK5X to 8X

Model No.	Spline shaft diameter		Spline nut dimensions											
	D ₀ h7	Outer diameter		Length			Flange outer diameter		H	F	E	E ₁	Lubrication hole d ₀	PCD
		D	Tolerance	L (With seal)	L ₁ (Without seal)	L ₂	D ₁	K						
LFK 5X LFK 5XL	5	10	0 -0.009	15 26	13.6 24.6	7.3 18.3	23	18	2.7	— 6.5	6.55	5.35	— 1	17
LFK 6X LFK 6XL	6	12	0 -0.011	19 30	17.6 28.6	10.2 21.2	25	20	2.7	2.4 7.9	7.1	5.9	1	19
LFK 8X LFK 8XL	8	15	0 -0.011	25 40	23.8 38.8	14.6 29.6	28	22	3.8	3.5 11	9	7.5	1.5	22
LFK 10X	10	19	0 -0.013	33	30.8	23.9	38	30	6	5.95	10.55	9.45	1.5	28
LFK 13X	13	23	0 -0.013	36	32.4	24	43	34	6	6	12	10.2	1.5	33
LFK 16X	16	28	0 -0.013	50	46.4	35.5	48	37	6	11.7	13.3	11.5	2	38
LFK 20X	20	32	0 -0.016	63	59	47.4	54	42	8	15.7	15.8	13.8	2	43
LFK 25X	25	40	0 -0.016	71	67	52.6	62	50	8	18.3	17.2	15.2	3	51
LFK 30X	30	45	0 -0.016	80	75.6	59.6	74	58	10	19.8	20.2	18	3	60

Model number coding

2 LFK20X UU CL +700L P K

Model No.	Symbol for clearance in the rotational direction ^(*)2)	Accuracy symbol ^(*)3)	Symbol for spline shaft ^(*)4)
Number of spline nuts on one shaft (no symbol for one nut)	Contamination protection accessory symbol ^(*)1)	Overall spline shaft length ^(*)5) (in mm)	

(*1) See **A3-126**. (*2) See **A3-30**. (*3) See **A3-35**. (*4) See **A3-93**. (*5) See **A3-121**.

Medium Torque Type Ball Spline

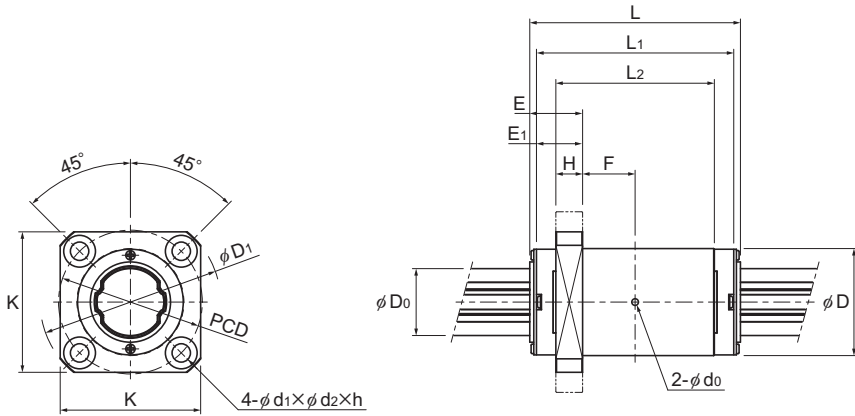

Models LFK10X to 30X

Unit: mm

	Mounting hole $d_1 \times d_2 \times h$	Basic torque rating		Basic load rating		Static permissible moment			Mass	
		C_T N·m	C_{OT} N·m	C kN	C_0 kN	M_{A1} N·m	M_{A2} (With seal) N·m	M_{A2} (Without seal) N·m	Spline Nut g	Spline shaft kg/m
	3.4 through	0.82 1.59	1.25 3.2	0.56 1.09	0.85 2.19	1.04 6.11	8.2 35.5	6.6 28.4	7.9 12.6	0.15
	3.4 through	1.73 2.81	2.77 5.54	0.98 1.6	1.58 3.15	2.85 10.6	19 59.8	15.2 47.8	11.6 18.3	0.21
	3.4 through	6 10.1	9.23 19.5	1.39 2.35	2.15 4.53	5.13 21.1	34.3 110.9	27.4 88.7	22.3 32.3	0.38
	4.5×8×4.4	9.41	17.3	2.94	5.4	21.5	114	104	54	0.59
	4.5×8×4.4	17.1	28.7	4.16	6.96	28.9	164	149	67	1.01
	4.5×8×4.4	42.9	68.6	8.4	13.4	77.4	419	381	110	1.52
	5.5×9.5×5.4	66.4	117	10.5	18.6	144	735	669	177	2.41
	5.5×9.5×5.4	125	207	15.9	26.2	230	1183	1077	298	3.71
	6.6×11×6.5	196	319	20.8	34	335	1714	1560	411	5.37

Note) The mass of the spline nut does not include the seal.
Please check the spline shaft strength tests (A3-12) before use.

Model LFH-X

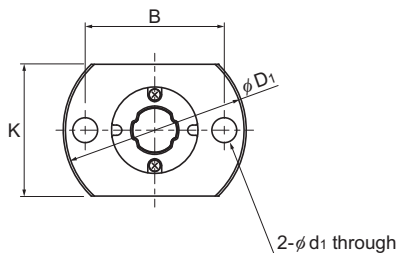

Models LFH5X to 13X

Model No.	Spline shaft diameter		Spline nut dimensions												
	D ₀ h7	Outer diameter		Length			Flange outer diameter		B	C	H	F	E	E ₁	Lubrication hole d ₀
		D	Tolerance	L (With seal)	L ₁ (Without seal)	L ₂	D ₁	K							
LFH 5X LFH 5XL	5	10	⁰ -0.009	15 26	13.6 24.6	7.3 18.3	23	16	17	—	2.7	[—] 6.5	6.55	5.35	[—] 1
LFH 6X LFH 6XL	6	12	⁰ -0.011	19 30	17.6 28.6	10.2 21.2	25	18	19	—	2.7	^{2.4} 7.9	7.1	5.9	1
LFH 8X LFH 8XL	8	15	⁰ -0.011	25 40	23.8 38.8	14.6 29.6	28	21	22	—	3.8	^{3.5} 11	9	7.5	1.5
LFH 10X	10	19	⁰ -0.013	33	30.8	23.9	38	25	29	—	6	5.95	10.55	9.45	1.5
LFH 13X	13	23	⁰ -0.013	36	32.4	24	43	29	33	—	6	6	12	10.2	1.5
LFH 16X	16	28	⁰ -0.013	50	46.4	35.5	48	34	31	22	6	11.7	13.3	11.5	2
LFH 20X	20	32	⁰ -0.016	63	59	47.4	54	38	36	24	8	15.7	15.8	13.8	2
LFH 25X	25	40	⁰ -0.016	71	67	52.6	62	46	40	32	8	18.3	17.2	15.2	3
LFH 30X	30	45	⁰ -0.016	80	75.6	59.6	74	51	49	35	10	19.8	20.2	18	3

Model number coding

2 LFH20X UU CL +700L P K

Model No.

Number of spline nuts
on one shaft
(no symbol for one nut)

Symbol for clearance
in the rotational direction
(⁽²⁾)

Contamination protection
accessory symbol (⁽¹⁾)

Accuracy
symbol (⁽³⁾)

Overall spline shaft length (⁽⁵⁾)
(in mm)

Symbol for spline shaft (⁽⁴⁾)

(*1) See **A3-126**. (*2) See **A3-30**. (*3) See **A3-35**. (*4) See **A3-93**. (*5) See **A3-121**.

Medium Torque Type Ball Spline

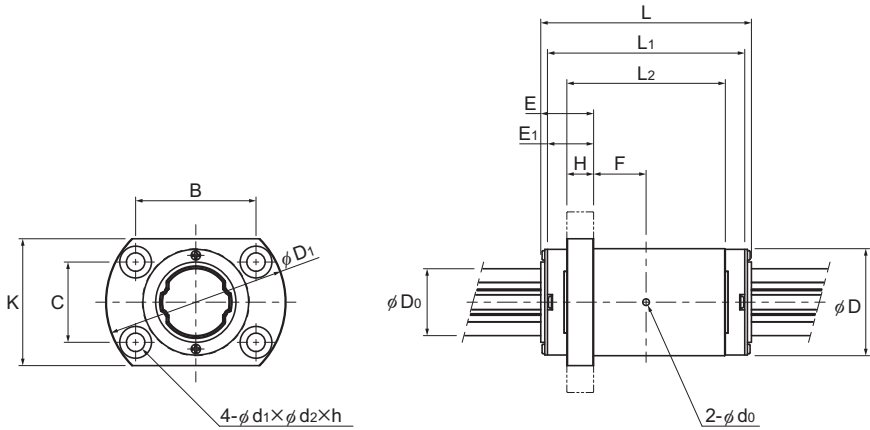

Models LFH16X to 30X

Unit: mm

	Mounting hole $d_1 \times d_2 \times h$	Basic torque rating		Basic load rating		Static permissible moment			Mass	
		C_T N·m	C_{OT} N·m	C kN	C_0 kN	M_{A1} N·m	M_{A2} (With seal) N·m	M_{A2} (Without seal) N·m	Spline Nut g	Spline shaft kg/m
	3.4 through	0.82 1.59	1.25 3.2	0.56 1.09	0.85 2.19	1.04 6.11	8.2 35.5	6.6 28.4	8.6 13.3	0.15
	3.4 through	1.73 2.81	2.77 5.54	0.98 1.6	1.58 3.15	2.85 10.6	19 59.8	15.2 47.8	12.4 19.1	0.21
	3.4 through	6 10.1	9.23 19.5	1.39 2.35	2.15 4.53	5.13 21.1	34.3 110.9	27.4 88.7	24.4 34.4	0.38
	4.5 through	9.41	17.3	2.94	5.4	21.5	114	104	59	0.59
	4.5 through	17.1	28.7	4.16	6.96	28.9	164	149	71	1.01
	4.5 × 8 × 4.4	42.9	68.6	8.4	13.4	77.4	419	381	116	1.52
	5.5 × 9.5 × 5.4	66.4	117	10.5	18.6	144	735	669	186	2.41
	5.5 × 9.5 × 5.4	125	207	15.9	26.2	230	1183	1077	306	3.71
	6.6 × 11 × 6.5	196	319	20.8	34	335	1714	1560	422	5.37

Note) The mass of the spline nut does not include the seal.
Please check the spline shaft strength tests (A3-12) before use.

Model LT with Recommended Shaft End Shape

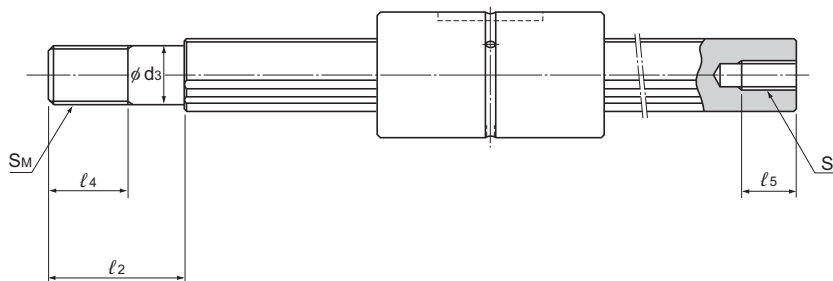

Unit: mm

Model No.	d_3	Tolerance	l_2	S_M	l_4	$S \times l_5$
LT 6	5	0	12	M5×0.8	7	M2.5×4
LT 8	6	-0.012	14	M6×1	8	M3×5
LT 10	8	0	18	M8×1	11	M4×6
LT 13	10	-0.015	23	M10×1.25	14	M5×8
LT 16	14	0	30	M14×1.5	18	M6×10
LT 20	16	-0.018	38	M16×1.5	22	M8×15
LT 25	22	0	50	M22×1.5	28	M10×18
LT 30	27	-0.021	60	M27×2	34	M14×25
LT 40	36	0	80	M36×3	45	M18×30
LT 50	45	-0.025	100	M45×4.5	58	M22×40

Spline Shaft

Spline shafts are divided in shape into precision solid spline shafts, special spline shafts, and hollow spline shafts (types K and N), as described on **A3-79**.

Since production of a spline shaft with a specific shape is performed at your request, provide a drawing of the desired shaft shape when requesting an estimate or placing an order.

[Sectional Shape of the Spline Shaft]

Table2 shows the sectional shape of a spline shaft. If the spline shaft ends need to be cylindrical, the minor diameter (ϕd) value should not be exceeded if possible.

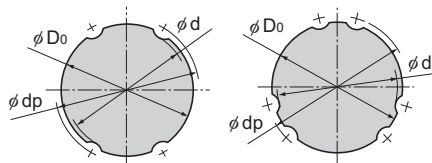

Model LT13 or smaller Model LT16 or greater

Table2 Cross-Sectional Shape of the Spline Shaft for Models LT and LF

Unit: mm

Nominal shaft diameter	4	5	6	8	10	13	16	20	25	30	40	50	60	80	100
Minor diameter ϕd	3.5	4.5	5	7	8.5	11.5	14.5	18.5	23	28	37.5	46.5	56.5	75.5	95
Major diameter ϕD_o h7	4	5	6	8	10	13	16	20	25	30	40	50	60	80	100
Ball center-to-center diameter ϕdp	4.6	5.7	7	9.3	11.5	14.8	17.8	22.1	27.6	33.2	44.2	55.2	66.3	87.9	109.5
Mass(kg/m)	0.1	0.15	0.23	0.4	0.62	1.1	1.6	2.5	3.9	5.6	9.9	15.5	22.3	39.6	61.8

*The minor diameter ϕd must be a value at which no groove is left after machining.

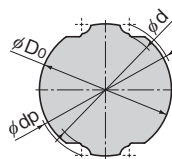

Table3 Cross-Sectional Shape of the Spline Shaft for Models LT-X, LF-X, LFK-X, and LFH-X

Unit: mm

Nominal shaft diameter	4	5	6	8	10	13	16	20	25	30
Minor diameter ϕd	3.6	4.5	5.4	7	8.6	11.3	13.9	17.9	22.4	27
Major diameter ϕD_o	4	5	6	8	10	13	16	20	25	30
Ball center-to-center diameter ϕdp	4.4	5.5	6.6	8.6	10.7	13.8	17.1	21.1	26.4	31.6
Mass (g/m)	100	150	210	380	590	1010	1520	2410	3710	5370

[Hole Shape of the Standard Hollow Type Spline Shaft]

Table4 shows the hole shape of the standard hollow type spline shaft (types K and N).

Use this table when a requirement such as piping, wiring, air-vent or weight reduction needs to be met.

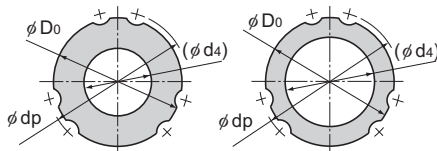

Type K (Thick)

Type N (Thin)

Table4 Cross-Sectional Shape of the Standard Hollow Spline Shaft for Models LT and LF

Unit: mm

Nominal shaft diameter	6	8	10	13	16	20	25	30	40	50	60	80	100	
Major diameter ϕD_0 h7	6	8	10	13	16	20	25	30	40	50	60	80	100	
Ball center-to-center diameter ϕdp	7	9.3	11.5	14.8	17.8	22.1	27.6	33.2	44.2	55.2	66.3	87.9	109.5	
Type K	Hole diameter (ϕd_4)	2.5	3	4	5	7	10	12	16	22	25	32	52.5	67.5
	Mass(kg/m)	0.2	0.35	0.52	0.95	1.3	1.8	3	4	6.9	11.6	16	22.6	33.7
Type N	Hole diameter (ϕd_4)	—	—	—	—	11	14	18	21	29	36	—	—	—
	Mass(kg/m)	—	—	—	—	0.8	1.3	1.9	2.8	4.7	7.4	—	—	—

Note) The standard hollow type Spline Shaft is divided into types K and N. Indicate "K" or "N" at the end of the model number to distinguish between them when placing an order.

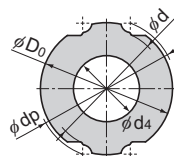

Type K (Thick)

Table5 Cross-Sectional Shape of the Hollow Spline Shaft for Models LT-X, LF-X, LFK-X, and LFH-X (K Type)

Unit: mm

Nominal shaft diameter	4	5	6	8	10	13	16	20	25	30
Minor diameter ϕd	—	—	5.4	7	8.6	11.3	13.9	17.9	22.4	27
Major diameter ϕD_0	—	—	6	8	10	13	16	20	25	30
Ball center-to-center diameter ϕdp	—	—	6.6	8.6	10.7	13.8	17.1	21.1	26.4	31.6
Hole diameter ϕd_4	—	—	2.5	3	4	5	7	10	12	16
Mass (g/m)	—	—	180	300	490	850	1220	1790	2820	3780

Note) The hollow spline shaft (K type) for models LT6X, LF6X, LFK6X, and LFH6X is made of carbon steel.

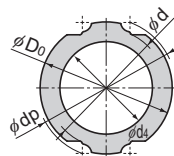

Type N (Thin)

Table6 Cross-Sectional Shape of the Hollow Spline Shaft for Models LT-X, LF-X, LFK-X, and LFH-X (N Type)

Unit: mm

Nominal shaft diameter	4	5	6	8	10	13	16	20	25	30
Minor diameter ϕd	—	—	—	—	—	—	13.9	17.9	22.4	27
Major diameter ϕD_0	—	—	—	—	—	—	16	20	25	30
Ball center-to-center diameter ϕdp	—	—	—	—	—	—	17.1	21.1	26.4	31.6
Hole diameter ϕd_4	—	—	—	—	—	—	11	14	18	21
Mass (g/m)	—	—	—	—	—	—	770	1190	1700	2630

[Chamfering of the Spline Shaft Ends]

To facilitate the insertion of the spline shaft into a spline nut, the shaft ends are normally chamfered with the dimensions indicated below unless otherwise specified.

The ends are chamfered whether they are used, such as with stepped, tapped, or drilled ends, or not used, such as with cantilevered supports.

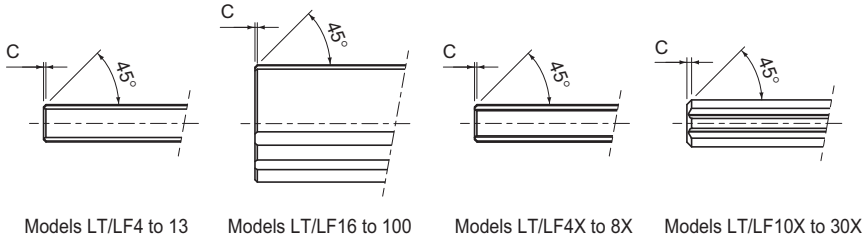

Table 7 Chamfer Dimensions of Model LT and Model LF Spline Shaft Ends

Unit: mm

Nominal shaft diameter	4	5	6	8	10	13	16	20	25	30	32	40	50	60	80	100
Chamfer C	0.3	0.3	0.5	0.5	0.5	0.5	0.5	0.5	0.5	0.5	0.5	1	1	2	2	2

Table 8 Chamfer Dimensions of Models LT-X, LF-X, LFK-X, and LFH-X Spline Shaft Ends

Unit: mm

Nominal shaft diameter	4	5	6	8	10	13	16	20	25	30
Chamfer C	0.3	0.3	0.5	0.5	1.5	1.5	1.5	1.5	2	2

[Length of the Incomplete Area of a Special Spline Shaft]

If the middle area or the end of a spline shaft is to be thicker than the minor diameter (ϕd), an imperfect spline area is required to secure a recess for grinding. Table 9 shows the relationship between the length of the incomplete section (S) and the flange diameter (ϕdf).

(This table does not apply to overall length of 1,500 mm or greater. Contact THK for details.)

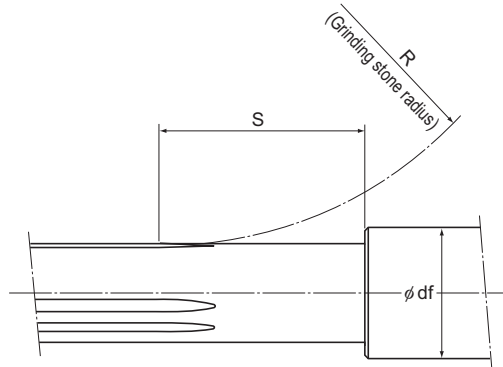

Table9 Length of Imperfect Spline Area: S Miniature type

Unit: mm

Flange diameter ϕ df	4	5	6	8	10
Nominal shaft diameter					
4	23	25	27	31	—
5	—	24	26	29	33

Standard Type

Unit: mm

Flange diameter ϕ df	Standard Type															
	6	8	10	13	16	20	25	30	40	50	60	80	100	120	140	160
Nominal shaft diameter																
6	24	28	31	39	—	—	—	—	—	—	—	—	—	—	—	—
8	—	25	29	35	41	—	—	—	—	—	—	—	—	—	—	—
10	—	—	26	31	38	45	—	—	—	—	—	—	—	—	—	—
13	—	—	—	33	39	46	56	—	—	—	—	—	—	—	—	—
16	—	—	—	—	36	47	58	67	—	—	—	—	—	—	—	—
20	—	—	—	—	—	37	50	60	76	—	—	—	—	—	—	—
25	—	—	—	—	—	—	38	51	72	88	—	—	—	—	—	—
30	—	—	—	—	—	—	—	40	62	80	95	—	—	—	—	—
40	—	—	—	—	—	—	—	—	42	63	81	107	—	—	—	—
50	—	—	—	—	—	—	—	—	—	45	65	96	118	—	—	—
60	—	—	—	—	—	—	—	—	—	—	50	87	114	134	—	—
80	—	—	—	—	—	—	—	—	—	—	—	53	89	115	135	—
100	—	—	—	—	—	—	—	—	—	—	—	—	57	90	116	136

*This table does not apply to overall length of 1,500 mm or greater. Contact THK for details.

Compact Type

Unit: mm

Flange diameter ϕ df	Compact Type													
	4	5	6	8	10	13	16	20	25	30	35	40	50	60
Nominal shaft diameter														
4X	23	25	27	31	—	—	—	—	—	—	—	—	—	—
5X	—	24	26	29	33	—	—	—	—	—	—	—	—	—
6X	—	—	24	28	31	39	—	—	—	—	—	—	—	—
8X	—	—	—	25	29	35	41	—	—	—	—	—	—	—
10X	—	—	—	—	26	40	48	56	—	—	—	—	—	—
13X	—	—	—	—	—	33	41	51	61	—	—	—	—	—
16X	—	—	—	—	—	—	36	47	58	67	—	—	—	—
20X	—	—	—	—	—	—	—	37	50	60	67	76	—	—
25X	—	—	—	—	—	—	—	—	38	51	59	72	88	—
30X	—	—	—	—	—	—	—	—	—	40	50	62	80	95

Accessories

Ball Spline model LT is provided with a standard key as indicated in Table10.

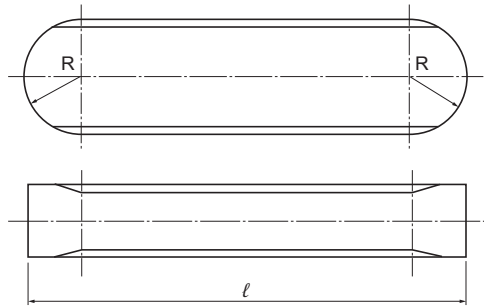
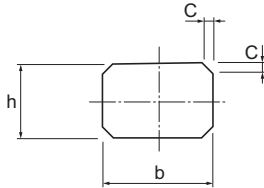

Table10 Standard Key for Model LT

Unit: mm

Nominal shaft diameter	Width b		Height h		Length ℓ		R	C	
		Tolerance(p7)		Tolerance(h9)		Tolerance(h12)			
LT 4	2	+0.016 +0.006	2	0 -0.025	6	0 -0.120	1	0.3	
LT 5	2.5		2.5		8	0 -0.150	1.25		
LT 5X	2		2		4.7	0	1	0.2	
LT 5XL	2		2		4.7	-0.120	1		
LT 6	2.5		2.5		10.5	0 -0.180	1.25	0.5	
LT 6X	2		2		6	0	1	0.3	
LT 6XL	2		2		6	-0.120	1		
LT 8	2.5		2.5		10.5	0 -0.180	1.25	0.5	
LT 8X	2.5		2.5		8	0	1.25		
LT 8XL	2.5		2.5		8	-0.150	1.25		
LT 10	3		3		13	0 -0.180	1.5	0.5	
LT 10X	3		3		13				
LT 13	3		3		15		0		1.5
LT 13X	3		3		15		-0.180		1.5
LT 16	3.5		+0.024 +0.012		3.5	0 -0.030	17.5	1.75	0.5
LT 16X	3.5				3.5		17.5	1.75	
LT 20	4				4		29	0	2
LT 20X	4				4		29	-0.210	2
LT 25	4				4		36	0 -0.250	2
LT 25X	4				4		36		0
LT 30	4	4		42	-0.250		2		
LT 30X	4	4		42	-0.250		2		
LT 40	6	6		52	0		3		
LT 50	8	+0.030 +0.015		7	0		4	0.8	
LT 60	12	+0.036		8	-0.036		6		
LT 80	16	+0.018		10	0		8		
LT 100	20	+0.043 +0.022	13	0 -0.043	110	0 -0.350			