

Model LM

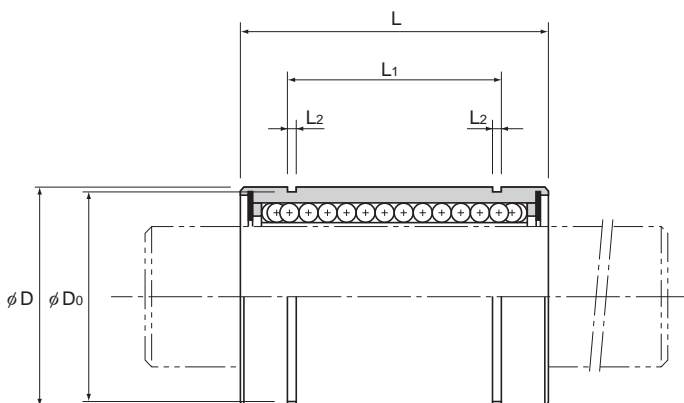

Model No.			Ball rows	Main							
Standard type	Clearance-adjustable type	Open type		Inscribed bore diameter		Outer diameter		Length			
				dr	Tolerance		D	Tolerance	L	Tolerance	
LM 3	—	—	4	3	0	0	7	0	10	0	
LM 4	—	—	4	4			8		-0.009		12
LM 5	—	—	4	5			10				15
LM 6	LM 6-AJ	—	4	6	12	0	19				
LM 8S	LM 8S-AJ	—	4	8	15		-0.011	17			
LM 8	LM 8-AJ	—	4	8	15			24			
LM 10	LM 10-AJ	—	4	10	0	0		19	0	29	
LM 12	LM 12-AJ	—	4	12			21	0		30	
LM 13	LM 13-AJ	LM 13-OP	4	13			23			-0.013	32
LM 16	LM 16-AJ	LM 16-OP	5	16	28	37					
LM 20	LM 20-AJ	LM 20-OP	5	20	32	0	42				
LM 25	LM 25-AJ	LM 25-OP	6	25	40		-0.016	59			
LM 30	LM 30-AJ	LM 30-OP	6	30	45			64			
LM 35	LM 35-AJ	LM 35-OP	6	35	52	0		70			
LM 40	LM 40-AJ	LM 40-OP	6	40	60		-0.019	80			
LM 50	LM 50-AJ	LM 50-OP	6	50	80			100			
LM 60	LM 60-AJ	LM 60-OP	6	60	90	0		110			

Note) Since this model contains a synthetic resin retainer, do not use it at temperature exceeding 80°C.

If the ambient temperature exceeds 80°C, use the type equipped with a metal retainer (model LM-GA).

If requiring a type equipped with a seal, indicate it when placing an order.

(Example) LM13 UU

U U Seal attached on both ends of the nut

For the clearance-adjustable type (-AJ) and open type (-OP), the inscribed bore diameter tolerance, the outer diameter tolerance, and the eccentricity indicate the values before the division of the nut.

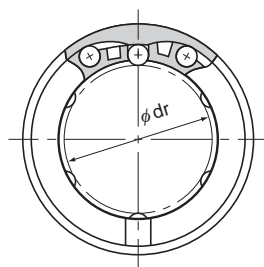

Model LM

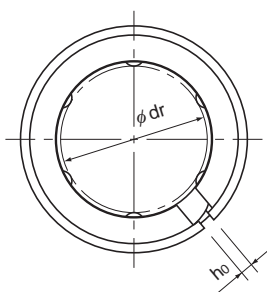

Model LM-AJ

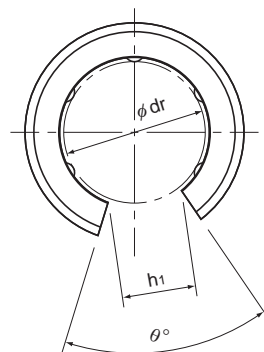

Model LM-OP

Unit: mm

	dimensions							Eccentricity (max)		Radial clearance tolerance μm	Basic load rating		
	L_1	Tolerance	L_2	D_o	h_o	h_1	θ°	μm			C N	C_o N	Mass g
								Precision	High				
—	—	—	—	—	—	—	—	4	8	-2	88.2	108	1.4
—	—	—	—	—	—	—	—	4	8	-3	88.2	127	1.9
10.2	0 -0.2	1.1	9.6	—	—	—	—	4	8	-3	167	206	4
13.5		1.1	11.5	1	—	—	—	8	12	-5	206	265	8
11.5		1.1	14.3	1	—	—	—	8	12	-5	176	225	11
17.5		1.1	14.3	1	—	—	—	8	12	-5	265	402	16
22		1.3	18	1	—	—	—	8	12	-5	373	549	30
23		1.3	20	1.5	8	80	—	8	12	-5	412	598	31.5
23		1.3	22	1.5	9	80	—	8	12	-7	510	775	43
26.5		1.6	27	1.5	11	60	—	8	12	-7	775	1180	69
30.5		1.6	30.5	1.5	11	60	—	10	15	-9	863	1370	87
41		0 -0.3	1.85	38	2	12	50	—	10	15	-9	980	1570
44.5	1.85		43	2.5	15	50	—	10	15	-9	1570	2750	250
49.5	2.1		49	2.5	17	50	—	12	20	-13	1670	3140	390
60.5	2.1		57	3	20	50	—	12	20	-13	2160	4020	585
74	2.6		76.5	3	25	50	—	12	20	-13	3820	7940	1580
85	3.15		86.5	3	30	50	—	17	25	-16	4710	10000	2000

Note) When using the Linear Bushing on a single shaft, use two or more units (instead of one unit) on the same shaft to avoid a moment load, and secure a large distance between the units.

If an oil hole is required, this can be indicated by appending "OH" to the end of the model number.

For further information, contact THK.

Model LM-GA (Metal Retainer Type)

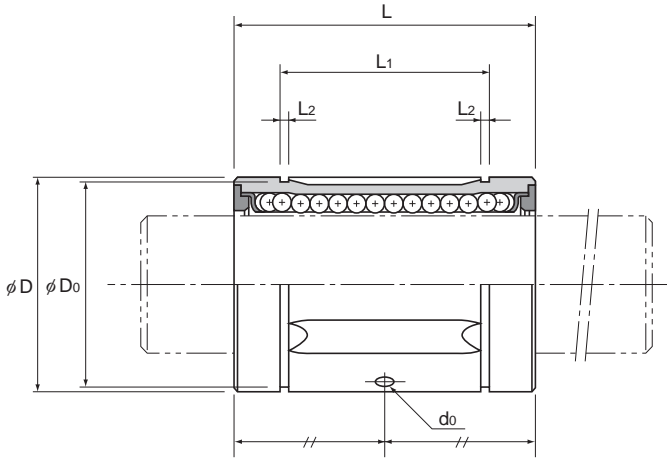

Model No.			Ball rows	Main										
Standard type	Clearance-adjustable type	Open type		Inscribed bore diameter		Outer diameter		Length						
				dr	Tolerance		D	Tolerance Precision/high	L	Tolerance				
LM 6GA	—	—	3	6	0	-0.006	0	-0.009	12	0	-0.011	19	0	-0.2
LM 8SGA	—	—	3	8					15			17		
LM 8GA	—	—	3	8					15			24		
LM 10GA	—	—	4	10					19	29				
LM 12GA	LM 12GA-AJ	LM 12GA-OP	4	12					21	30				
LM 13GA	LM 13GA-AJ	LM 13GA-OP	4	13					23	32				
LM 16GA	LM 16GA-AJ	LM 16GA-OP	4	16	28	37								
LM 20GA	LM 20GA-AJ	LM 20GA-OP	5	20	32	42	0	-0.007	0	-0.010	45	64		
LM 25GA	LM 25GA-AJ	LM 25GA-OP	5	25	40	59								
LM 30GA	LM 30GA-AJ	LM 30GA-OP	6	30	45	64								
LM 35GA	LM 35GA-AJ	LM 35GA-OP	6	35	52	70								
LM 38GA	LM 38GA-AJ	LM 38GA-OP	6	38	57	76								
LM 40GA	LM 40GA-AJ	LM 40GA-OP	6	40	60	80								
LM 50GA	LM 50GA-AJ	LM 50GA-OP	6	50	80	100	0	-0.008	0	-0.012	110	140		
LM 60GA	LM 60GA-AJ	LM 60GA-OP	6	60	90	110								
LM 80GA	LM 80GA-AJ	LM 80GA-OP	6	80	120	140								
LM 100GA	LM 100GA-AJ	LM 100GA-OP	6	100	150	175								
LM 120A	LM 120A-AJ	LM 120A-OP	8	120	180	200								
					0	0					0	0	0	0

Note) If requiring a type equipped with a seal, indicate it when placing an order. (seal heat resistance: 80°C.)

(Example) LM50GA UU

Seal attached on both ends of the nut

For the clearance-adjustable type (-AJ) and open type (-OP), the inscribed bore diameter tolerance, the outer diameter tolerance, and the eccentricity indicate the values before the division of the nut.

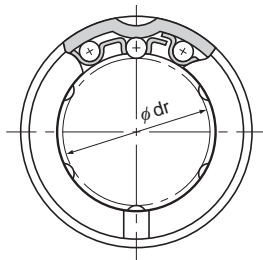

Model LM-GA

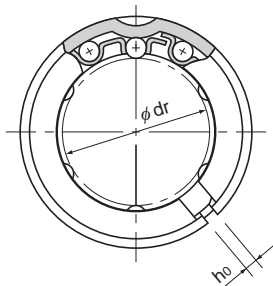

Model LM-GA-AJ

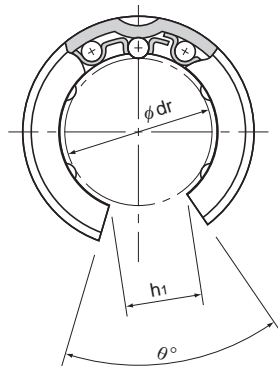

Model LM-GA-OP

Unit: mm

dimensions								Greasing hole d _o	Eccentricity (max) μm		Radial clearance tolerance μm	Basic load rating		Mass g
L ₁	Tolerance	L ₂	D ₀	h ₀	h ₁	θ°	Precision		High	C N		C ₀ N		
13.5	0 -0.2	1.1	11.5	—	—	—	—	8	12	-5	206	265	8	
11.5		1.1	14.3	—	—	—	—	8	12	-5	176	225	11	
17.5		1.1	14.3	—	—	—	—	8	12	-5	265	402	16	
22		1.3	18	—	—	—	—	2	8	12	-5	373	549	30
23		1.3	20	1.5	7.5	80	2	8	12	-5	412	598	31.5	
23		1.3	22	1.5	9	80	2	8	12	-7	510	775	43	
26.5		1.6	27	1.5	11	60	2.3	8	12	-7	775	1180	69	
30.5		1.6	30.5	2	11	60	2.3	10	15	-9	863	1370	87	
41	0 -0.3	1.85	38	2	13	60	3	10	15	-9	980	1570	220	
44.5		1.85	43	2.5	15	50	3	10	15	-9	1570	2750	250	
49.5		2.1	49	2.5	17	50	3	12	20	-13	1670	3140	390	
58.5		2.1	54.5	3	18	50	3	12	20	-13	2160	4020	565	
60.5		2.1	57	3	20	50	3	12	20	-13	2160	4020	585	
74		2.6	76.5	3	25	50	4	12	20	-13	3820	7940	1580	
85		3.15	86.5	3	30	50	4	17	25	-16	4710	10000	2000	
105.5		0 -0.4	4.15	116	3	40	50	4	17	25	-16	7350	16000	4520
125.5	4.15		145	3	50	50	4	20	30	-20	14100	34800	8600	
158.6	4.15		175	4	85	80	5	20	30	-25	16400	40000	15000	

Note) When using the Linear Bushing on a single shaft, use two or more bushings on the same shaft to minimize a moment load, and secure a large distance between the units.

Model LM-GA has oil holes as a standard feature.

If an oil hole is required, this can be indicated by appending "OH" to the end of the model number.

For further information, contact THK.

Model LM-MG (Stainless Steel Type)

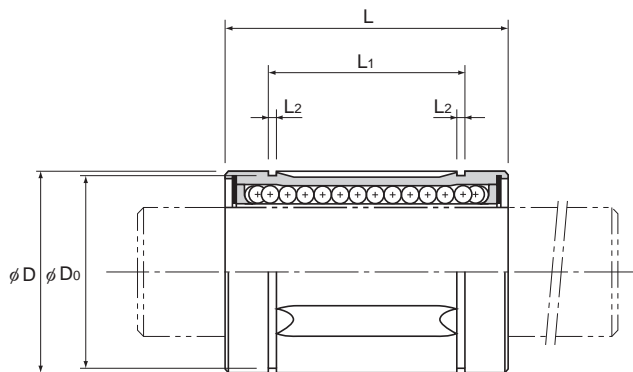

Model No.			Ball rows	Main						
Standard type	Clearance-adjustable type	Open type		Inscribed bore diameter		Outer diameter		Length		
				dr	Tolerance		D	Tolerance	L	Tolerance
				Precision	High		Precision/high			
LM 3M	—	—	4	3	0 -0.005	0 -0.008	7	0 -0.009	10	0 -0.12
LM 4M	—	—	4	4			8		12	
LM 5M	—	—	4	5			10		15	
* LM 6MG	LM 6MG-AJ	—	4	6	0 -0.006	0 -0.009	12	0 -0.011	19	0 -0.2
* LM 8SMG	LM 8SMG-AJ	—	4	8			15		17	
* LM 8MG	* LM 8MG-AJ	—	4	8			15		24	
* LM 10MG	* LM 10MG-AJ	—	4	10			19		29	
* LM 12MG	* LM 12MG-AJ	—	4	12			21		30	
* LM 13MG	* LM 13MG-AJ	* LM13MGA-OP	4	13			23		32	
* LM 16MG	* LM 16MG-AJ	* LM16MGA-OP	4	16	28	37				
* LM 20MG	* LM 20MG-AJ	* LM20MGA-OP	5	20	0 -0.007	0 -0.010	32	0 -0.016	42	0 -0.3
* LM 25MG	* LM 25MG-AJ	* LM25MGA-OP	5	25			40		59	
* LM 30MG	* LM 30MG-AJ	* LM30MGA-OP	6	30			45		64	
* LM 35MG	* LM 35MG-AJ	* LM35MGA-OP	6	35			52		70	
* LM 40MG	* LM 40MG-AJ	* LM40MGA-OP	6	40			60		80	

Note) Since this model contains a synthetic resin retainer, do not use it at temperature exceeding 80°C.

If the ambient temperature exceeds 80°C, use the type equipped with a metal retainer and indicate "A" at the end of the model number.

(For those marked with * in the table, metal retainers are available. Only metal retainer is available for open type.)

(Metal retainer types of models LM6MG, 8SMG and 8MG each have 3 rows of balls.)

(Example) LM30MG A

High temperature symbol

If requiring a type equipped with a seal, indicate it when placing an order. (seal heat resistance: 80°C.)

(Example) LM30MG UU

Seal attached on both ends of the nut

For the clearance-adjustable type (-AJ) and open type (-OP), the inscribed bore diameter tolerance, the outer diameter tolerance, and the eccentricity indicate the values before the division of the nut.

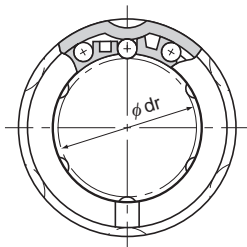

Model LM-MG

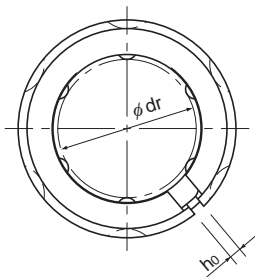

Model LM-MG-AJ

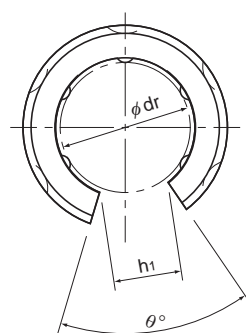

Model LM-MG-OP

Unit: mm

dimensions								Eccentricity (max) μm		Radial clearance tolerance μm	Basic load rating		
L_1	Tolerance	L_2	D_0	h_0	h_1	θ°	Precision	High	C N		C_0 N	Mass g	
—	—	—	—	—	—	—	4	8	-2	88.2	108	1.4	
—	—	—	—	—	—	—	4	8	-3	88.2	127	1.9	
10.2	0 -0.2	1.1	9.6	—	—	—	4	8	-3	167	206	4	
13.5		1.1	11.5	1	—	—	8	12	-5	206	265	8	
11.5		1.1	14.3	1	—	—	8	12	-5	176	225	11	
17.5		1.1	14.3	1	—	—	8	12	-5	265	402	16	
22		1.3	18	1	—	—	8	12	-5	373	549	30	
23		1.3	20	1.5	—	—	8	12	-5	412	598	31.5	
23		1.3	22	1.5	9	80	8	12	-7	510	775	43	
26.5		1.6	27	1.5	11	80	8	12	-7	775	1180	69	
30.5		1.6	30.5	1.5	11	60	10	15	-9	863	1370	87	
41		0 -0.3	1.85	38	2	12	50	10	15	-9	980	1570	220
44.5	1.85		43	2.5	15	50	10	15	-9	1570	2750	250	
49.5	2.1		49	2.5	17	50	12	20	-13	1670	3140	390	
60.5	2.1		57	3	20	50	12	20	-13	2160	4020	585	

Note) Since the nut and the balls use stainless steel, these models are highly resistant to corrosion and environment.
If an oil hole is required, this can be indicated by appending "OH" to the end of the model number.

For further information, contact THK.

When using the Linear Bushing on a single shaft, use two or more bushings on the same shaft to minimize a moment load, and secure a large distance between the units.

Model LME

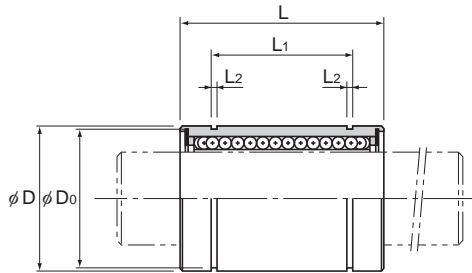

Model No.			Ball rows	Main					
Standard type	Clearance-adjustable type	Open type		Inscribed bore diameter		Outer diameter		Length	
				dr	Tolerance	D	Tolerance	L	Tolerance
LME 5	LME 5-AJ	—	4	5	+0.008 0	12	0	22	0 -0.2
LME 8	LME 8-AJ	—	4	8		16	-0.008	25	
LME 12	LME 12-AJ	—	4	12	22	0	32		
LME 16	LME 16-AJ	LME 16-OP	5	16	+0.009	26	-0.009	36	
LME 20	LME 20-AJ	LME 20-OP	5	20	-0.001	32	0 -0.011	45	0 -0.3
LME 25	LME 25-AJ	LME 25-OP	6	25	+0.011	40		0	
LME 30	LME 30-AJ	LME 30-OP	6	30	-0.001	47	-0.011	68	
LME 40	LME 40-AJ	LME 40-OP	6	40	+0.013 -0.002	62	0	80	
LME 50	LME 50-AJ	LME 50-OP	6	50		75	-0.013	100	
LME 60	LME 60-AJ	LME 60-OP	6	60	+0.016 -0.004	90	0 -0.015	125	0 -0.4
LME 80GA	LME 80GA-AJ	LME 80GA-OP	6	80		120		0	

Note) Since Linear Bushing models LME60 or smaller models are incorporated with a synthetic resin retainer, do not use them at temperature exceeding 80°C.

If the ambient temperature exceeds 80°C, use the type equipped with a metal retainer and indicate "A" at the end of the model number.

(Example) LME20G A

High temperature symbol

If requiring a type equipped with a seal, indicate it when placing an order. (seal heat resistance: 80°C.)

(Example) LME16 UU

Seal attached on both ends of the nut

For the clearance-adjustable type (-AJ) and open type (-OP), the inscribed bore diameter tolerance, the outer diameter tolerance, and the eccentricity indicate the values before the division of the nut.

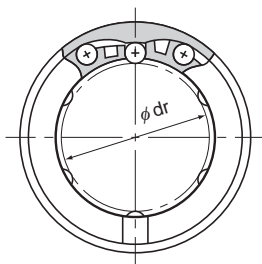

Model LME

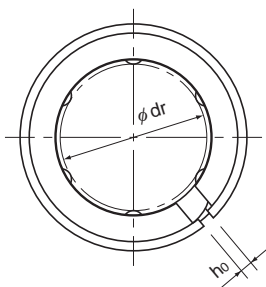

Model LME-AJ

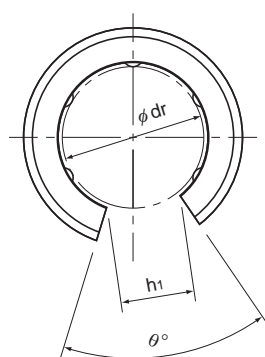

Model LME-OP

Unit: mm

dimensions								Eccentricity (max)	Radial clearance tolerance	Basic load rating		Mass g
L_1	Tolerance	L_2	D_0	h_0	h_1	θ°	μm			μm	C N	
14.5	0 -0.2	1.1	11.5	1	—	—	12	-5	206	265	11	
16.5		1.1	15.2	1	—	—	12	-5	265	402	20	
22.9		1.3	21	1.5	7.5	78	12	-7	510	775	41	
24.9		1.3	24.9	1.5	10	78	12	-7	775	1180	57	
31.5		1.6	30.3	2	10	60	15	-9	863	1370	91	
44.1	0 -0.3	1.85	37.5	2	12.5	60	15	-9	980	1570	215	
52.1		1.85	44.5	2	12.5	50	15	-9	1570	2750	325	
60.6		2.15	59	3	16.8	50	17	-13	2160	4020	705	
77.6		2.65	72	3	21	50	17	-13	3820	7940	1130	
101.7	0 -0.4	3.15	86.5	3	27.2	54	20	-16	4710	10000	2220	
133.7		4.15	116	3	36.3	54	20	-16	7350	16000	5140	

Note) If a metal retainer is used, the Linear Bushing has the shape as shown below.

When using the Linear Bushing on a single shaft, use two or more units (instead of one unit) on the same shaft to avoid a moment load, and secure a large distance between the units.

If an oil hole is required, this can be indicated by appending "OH" to the end of the model number.

For further information, contact THK.



Model LME-GA

Model LM-L

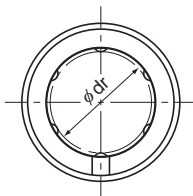

Model LM-L

Model No.	Ball rows	Main					
		Inscribed bore diameter		Outer diameter		Length	
		dr	Tolerance	D	Tolerance	L	Tolerance
LM 3L	4	3	0 -0.010	7	0 -0.013	19	0 -0.3
LM 4L	4	4		8		23	
LM 5L	4	5		10		29	
LM 6L	4	6		12		35	
LM 8L	4	8		15		45	
LM 10L	4	10		19	55		
LM 12L	4	12		21	0 -0.016	57	
LM 13L	4	13		23	61		
LM 16L	5	16		28	70		
LM 20L	5	20		32	0 -0.019	80	
LM 25L	6	25	40	112	0 -0.4		
LM 30L	6	30	45	123			
LM 35L	6	35	52	135			
LM 40L	6	40	0 -0.022	154			
LM 50L	6	50	80	192			
LM 60L	6	60	0 -0.020	90		0 -0.025	211

Note) Since this model contains a synthetic resin retainer, do not use it at temperature exceeding 80°C.
If requiring a type equipped with a seal, indicate it when placing an order.

(Example) LM13L UU

 Seal attached on both ends of the nut

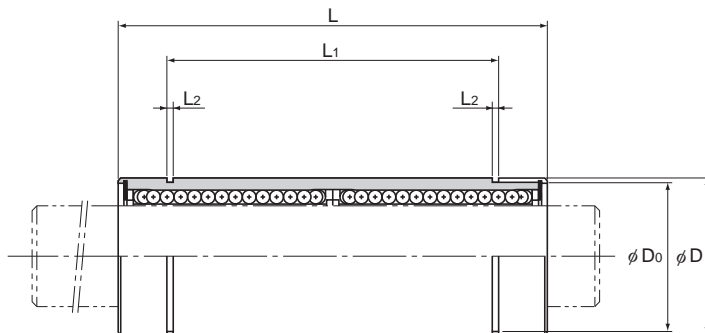

Unit: mm

dimensions					Eccentricity (max) μm	Radial clearance tolerance μm	Basic load rating		Mass g
L ₁	Tolerance	L ₂	D ₀	C N			C ₀ N		
—	—	—	—	10	-2	139	216	3	
—		—	—	10	-3	139	254	4	
20	0 -0.3	1.1	9.6	10	-3	263	412	8	
27		1.1	11.5	15	-5	324	529	16	
35		1.1	14.3	15	-5	431	784	31	
44		1.3	18	15	-5	588	1100	62	
46		1.3	20	15	-5	657	1200	80	
46		1.3	22	15	-7	814	1570	90	
53		1.6	27	15	-7	1230	2350	145	
61		1.6	30.5	20	-9	1400	2750	180	
82		0 -0.4	1.85	38	20	-9	1560	3140	440
89			1.85	43	20	-9	2490	5490	580
99	2.1		49	25	-13	2650	6270	795	
121	2.1		57	25	-13	3430	8040	1170	
148	2.6		76.5	25	-13	6080	15900	3100	
170	3.15		86.5	25	-16	7650	20000	3500	

Note) A stainless steel type is also available. Contact THK for details.
 If an oil hole is required, this can be indicated by appending "OH" to the end of the model number.
 For further information, contact THK.

Model LMF

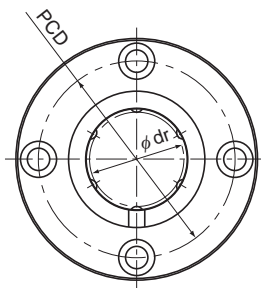

Model LMF

Model No.	Ball rows	Main dimensions							
		Inscribed bore diameter		Outer diameter		Length		Flange diameter	
		dr	Tolerance	D	Tolerance	L	Tolerance	D _i	Tolerance
LMF 6	4	6	0 -0.009	12	0 -0.011	19	0 -0.2	28	0 -0.2
LMF 8S	4	8		15		17		32	
LMF 8	4	8		15	24	32			
LMF 10	4	10		19	29	39			
LMF 12	4	12	21	0 -0.013	30	42			
LMF 13	4	13	23	32	43				
LMF 16	5	16	28	37	48				
LMF 20	5	20	32	42	54				
LMF 25	6	25	0 -0.010	40	0 -0.016	59	62		
LMF 30	6	30	45	64	74				
LMF 35	6	35	0	52	0	70	82		
LMF 40	6	40	-0.012	60	-0.019	80	96		
LMF 50	6	50	0	80	0	100	116		
LMF 60	6	60	0 -0.015	90	0 -0.022	110	134	0 -0.3	

Note) Since this model contains a synthetic resin retainer, do not use it at temperature exceeding 80°C.
If requiring a type equipped with a seal, indicate it when placing an order.

(Example) LMF25 UU

└── Seal attached on both ends of the nut

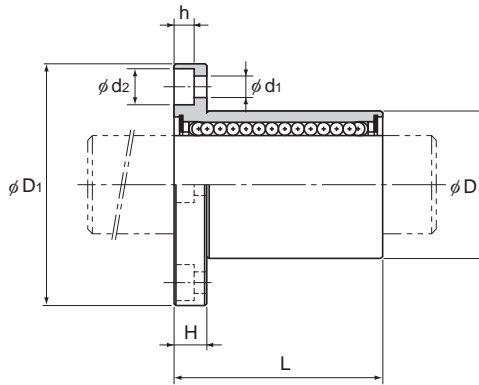

Unit: mm

	H	PCD	Mounting hole d ₁ × d ₂ × h	Flange perpendicularity	Eccentricity (max)	Radial clearance tolerance	Basic load rating		Mass g
				μm	μm	μm	C N	C ₀ N	
	5	20	3.4 × 6.5 × 3.3	12	12	-5	206	265	26.5
	5	24	3.4 × 6.5 × 3.3	12	12	-5	176	225	34
	5	24	3.4 × 6.5 × 3.3	12	12	-5	265	402	40
	6	29	4.5 × 8 × 4.4	12	12	-5	373	549	78
	6	32	4.5 × 8 × 4.4	12	12	-5	412	598	76
	6	33	4.5 × 8 × 4.4	12	12	-7	510	775	94
	6	38	4.5 × 8 × 4.4	12	12	-7	775	1180	134
	8	43	5.5 × 9.2 × 5.4	15	15	-9	863	1370	180
	8	51	5.5 × 9.2 × 5.4	15	15	-9	980	1570	340
	10	60	6.6 × 11 × 6.5	15	15	-9	1570	2750	460
	10	67	6.6 × 11 × 6.5	20	20	-13	1670	3140	795
	13	78	9 × 14 × 8.6	20	20	-13	2160	4020	1054
	13	98	9 × 14 × 8.6	20	20	-13	3820	7940	2200
	18	112	11 × 17.5 × 10.8	25	25	-13	4710	10000	2960

Note) If an oil hole is required, this can be indicated by appending "OH" to the end of the model number.
For further information, contact THK.

Model LMF-M (Stainless Steel Type)

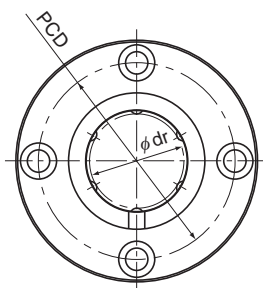

Model LMF-M

Model No.	Ball rows	Main dimensions							
		Inscribed bore diameter		Outer diameter		Length		Flange diameter	
		dr	Tolerance	D	Tolerance	L	Tolerance	D _i	Tolerance
LMF 6M	4	6	0 -0.009	12	0 -0.011	19	0 -0.2	28	0 -0.2
LMF 8SM	4	8		15		17		32	
LMF 8M	4	8		15	24	32			
LMF 10M	4	10		19	29	39			
LMF 12M	4	12	21	0 -0.013	30	42			
LMF 13M	4	13	23	32	43				
LMF 16M	5	16	28	37	48				
LMF 20M	5	20	32	0 -0.016	42	54			
LMF 25M	6	25	40	59	0	62			
LMF 30M	6	30	45	64	-0.3	74			

Note) Since this model contains a synthetic resin retainer, do not use it at temperature exceeding 80°C.
If requiring a type equipped with a seal, indicate it when placing an order.

(Example) LMF20M UU

└── Seal attached on both ends of the nut

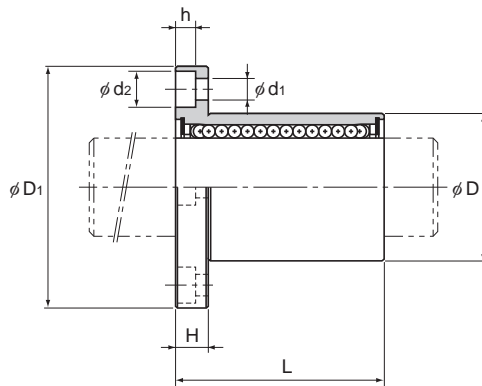

Unit: mm

	H	PCD	Mounting hole d ₁ × d ₂ × h	Flange perpendicularity	Eccentricity (max)	Radial clearance tolerance	Basic load rating		Mass g
				μm	μm	μm	C N	C ₀ N	
	5	20	3.4 × 6.5 × 3.3	12	12	-5	206	265	26.5
	5	24	3.4 × 6.5 × 3.3	12	12	-5	176	225	34
	5	24	3.4 × 6.5 × 3.3	12	12	-5	265	402	40
	6	29	4.5 × 8 × 4.4	12	12	-5	373	549	78
	6	32	4.5 × 8 × 4.4	12	12	-5	412	598	76
	6	33	4.5 × 8 × 4.4	12	12	-7	510	775	94
	6	38	4.5 × 8 × 4.4	12	12	-7	775	1180	134
	8	43	5.5 × 9.2 × 5.4	15	15	-9	863	1370	180
	8	51	5.5 × 9.2 × 5.4	15	15	-9	980	1570	340
	10	60	6.6 × 11 × 6.5	15	15	-9	1570	2750	460

Note) Since the nut and the balls use stainless steel, these models are highly resistant to corrosion and environment.
If an oil hole is required, this can be indicated by appending "OH" to the end of the model number.
For further information, contact THK.

Model LMF-L

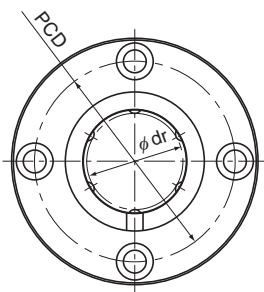

Model LMF-L

Model No.	Ball rows	Main dimensions							
		Inscribed bore diameter		Outer diameter		Length		Flange diameter	
		dr	Tolerance	D	Tolerance	L	Tolerance	D ₁	Tolerance
LMF 6L	4	6	0 -0.010	12	0	35	0 -0.3	28	0 -0.2
LMF 8L	4	8		15	-0.013	45		32	
LMF 10L	4	10		19	0 -0.016	55		39	
LMF 12L	4	12		21		57		42	
LMF 13L	4	13		23		61		43	
LMF 16L	5	16		28	0 -0.012	70		0 -0.4	
LMF 20L	5	20	32	80		54			
LMF 25L	6	25	40	0 -0.019		112	62		
LMF 30L	6	30	45	123		74			
LMF 35L	6	35	52	0 -0.022		135	82		
LMF 40L	6	40	60			154	96		
LMF 50L	6	50	80		192	116			
LMF 60L	6	60	0 -0.020	90	0 -0.025	211	134	0 -0.3	

Note) Since this model contains a synthetic resin retainer, do not use it at temperature exceeding 80°C.
If requiring a type equipped with a seal, indicate it when placing an order.

(Example) LMF35L UU

└─── Seal attached on both ends of the nut

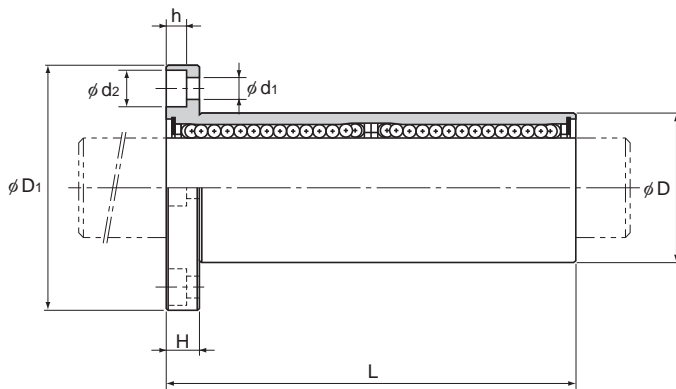

Unit: mm

	H	PCD	Mounting hole d ₁ × d ₂ × h	Flange perpendicularity	Eccentricity (max)	Radial clearance tolerance	Basic load rating		Mass g
				μm	μm	μm	C N	C ₀ N	
	5	20	3.4 × 6.5 × 3.3	15	15	-5	324	529	32
	5	24	3.4 × 6.5 × 3.3	15	15	-5	431	784	53
	6	29	4.5 × 8 × 4.4	15	15	-5	588	1100	105
	6	32	4.5 × 8 × 4.4	15	15	-5	657	1200	100
	6	33	4.5 × 8 × 4.4	15	15	-7	814	1570	130
	6	38	4.5 × 8 × 4.4	15	15	-7	1230	2350	187
	8	43	5.5 × 9.2 × 5.4	20	20	-9	1400	2750	260
	8	51	5.5 × 9.2 × 5.4	20	20	-9	1560	3140	515
	10	60	6.6 × 11 × 6.5	20	20	-9	2490	5490	655
	10	67	6.6 × 11 × 6.5	25	25	-13	2650	6270	970
	13	78	9 × 14 × 8.6	25	25	-13	3430	8040	1560
	13	98	9 × 14 × 8.6	25	25	-13	6080	15900	3500
	18	112	11 × 17.5 × 10.8	25	25	-13	7650	20000	4500

Note) If an oil hole is required, this can be indicated by appending "OH" to the end of the model number.
For further information, contact THK.

Model LMF-ML (Stainless Steel Type)

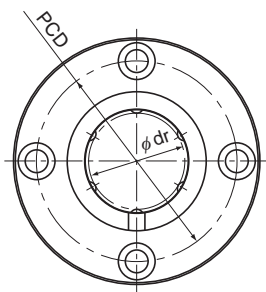

Model LMF-ML

Model No.	Ball rows	Main dimensions							
		Inscribed bore diameter		Outer diameter		Length		Flange diameter	
		dr	Tolerance	D	Tolerance	L	Tolerance	D ₁	Tolerance
LMF 6ML	4	6	0 -0.010	12	0	35	0 -0.3	28	0 -0.2
LMF 8ML	4	8		15	-0.013	45		32	
LMF 10ML	4	10		19	0 -0.016	55		39	
LMF 12ML	4	12		21		57		42	
LMF 13ML	4	13	23	0 -0.019	61	43			
LMF 16ML	5	16	28		70	48			
LMF 20ML	5	20	32	0 -0.012	80	54			
LMF 25ML	6	25	40		112	0	62		
LMF 30ML	6	30	45		123	-0.4	74		

Note) Since this model contains a synthetic resin retainer, do not use it at temperature exceeding 80°C.
If requiring a type equipped with a seal, indicate it when placing an order.

(Example) LMF13ML UU

└─── Seal attached on both ends of the nut

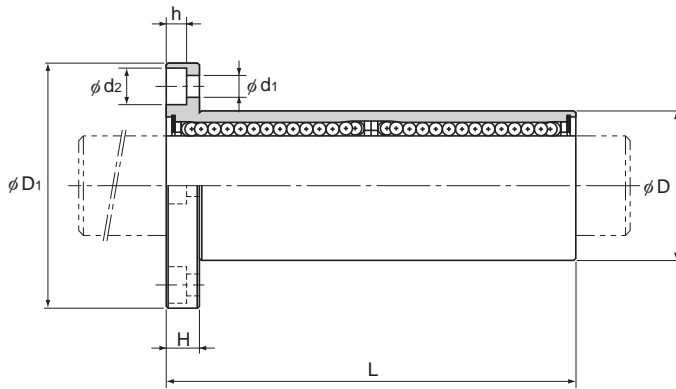

Unit: mm

	H	PCD	Mounting hole d. × d. × h	Flange perpendicularity	Eccentricity (max)	Radial clearance tolerance	Basic load rating		Mass g
				μm	μm	μm	C N	C ₀ N	
	5	20	3.4 × 6.5 × 3.3	15	15	-5	324	529	32
	5	24	3.4 × 6.5 × 3.3	15	15	-5	431	784	53
	6	29	4.5 × 8 × 4.4	15	15	-5	588	1100	105
	6	32	4.5 × 8 × 4.4	15	15	-5	657	1200	100
	6	33	4.5 × 8 × 4.4	15	15	-7	814	1570	130
	6	38	4.5 × 8 × 4.4	15	15	-7	1230	2350	187
	8	43	5.5 × 9.2 × 5.4	20	20	-9	1400	2750	260
	8	51	5.5 × 9.2 × 5.4	20	20	-9	1560	3140	515
	10	60	6.6 × 11 × 6.5	20	20	-9	2490	5490	655

Note) Since the nut and the balls use stainless steel, these models are highly resistant to corrosion and environment.
If an oil hole is required, this can be indicated by appending "OH" to the end of the model number.
For further information, contact THK.

Model LMK

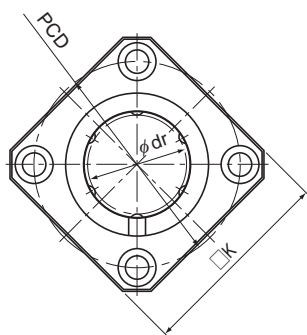

Model LMK

Model No.	Ball rows	Main dimensions							
		Inscribed bore diameter		Outer diameter		Length		Flange diameter	
		dr	Tolerance	D	Tolerance	L	Tolerance	D _i	Tolerance
LMK 6	4	6	0 -0.009	12	0 -0.011	19	0 -0.2	28	0 -0.2
LMK 8S	4	8		15		17		32	
LMK 8	4	8		15		24		32	
LMK 10	4	10		19	29	39			
LMK 12	4	12		21	30	42			
LMK 13	4	13		23	32	43			
LMK 16	5	16		28	37	48			
LMK 20	5	20		32	42	54			
LMK 25	6	25		40	59	62			
LMK 30	6	30		45	64	74			
LMK 35	6	35	52	70	82				
LMK 40	6	40	60	80	96				
LMK 50	6	50	80	100	116				
LMK 60	6	60	90	110	134				

Note) Since this model contains a synthetic resin retainer, do not use it at temperature exceeding 80°C.
If requiring a type equipped with a seal, indicate it when placing an order.

(Example) LMK13 UU

└── Seal attached on both ends of the nut

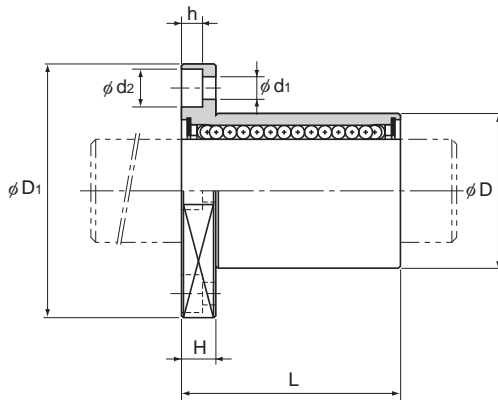

Unit: mm

	K	H	PCD	Mounting hole $d_1 \times d_2 \times h$	Flange perpendicularity μm	Eccentricity (max) μm	Radial clearance tolerance μm	Basic load rating		Mass g
								C N	C_0 N	
	22	5	20	$3.4 \times 6.5 \times 3.3$	12	12	-5	206	265	18.5
	25	5	24	$3.4 \times 6.5 \times 3.3$	12	12	-5	176	225	23
	25	5	24	$3.4 \times 6.5 \times 3.3$	12	12	-5	265	402	29
	30	6	29	$4.5 \times 8 \times 4.4$	12	12	-5	373	549	61
	32	6	32	$4.5 \times 8 \times 4.4$	12	12	-5	412	598	56
	34	6	33	$4.5 \times 8 \times 4.4$	12	12	-7	510	775	75
	37	6	38	$4.5 \times 8 \times 4.4$	12	12	-7	775	1180	104
	42	8	43	$5.5 \times 9.2 \times 5.4$	15	15	-9	863	1370	145
	50	8	51	$5.5 \times 9.2 \times 5.4$	15	15	-9	980	1570	300
	58	10	60	$6.6 \times 11 \times 6.5$	15	15	-9	1570	2750	375
	64	10	67	$6.6 \times 11 \times 6.5$	20	20	-13	1670	3140	692
	75	13	78	$9 \times 14 \times 8.6$	20	20	-13	2160	4020	864
	92	13	98	$9 \times 14 \times 8.6$	20	20	-13	3820	7940	2020
	106	18	112	$11 \times 17.5 \times 10.8$	25	25	-13	4710	10000	2520

Note) If an oil hole is required, this can be indicated by appending "OH" to the end of the model number.
For further information, contact THK.

Model LMK-M (Stainless Steel Type)

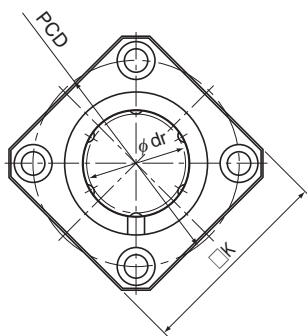

Model LMK-M

Model No.	Ball rows	Main dimensions							
		Inscribed bore diameter		Outer diameter		Length		Flange diameter	
		dr	Tolerance	D	Tolerance	L	Tolerance	D _f	Tolerance
LMK 6M	4	6	0 -0.009	12	0 -0.011	19	0 -0.2	28	0 -0.2
LMK 8SM	4	8		15		17		32	
LMK 8M	4	8		15	24	32			
LMK 10M	4	10		19	29	39			
LMK 12M	4	12	21	0 -0.013	30	42			
LMK 13M	4	13	23	32	43				
LMK 16M	5	16	28	37	48				
LMK 20M	5	20	32	0 -0.016	42	54			
LMK 25M	6	25	40	59	0	62			
LMK 30M	6	30	45	64	-0.3	74			

Note) Since this model contains a synthetic resin retainer, do not use it at temperature exceeding 80°C.
If requiring a type equipped with a seal, indicate it when placing an order.

(Example) LMK25M UU

└── Seal attached on both ends of the nut

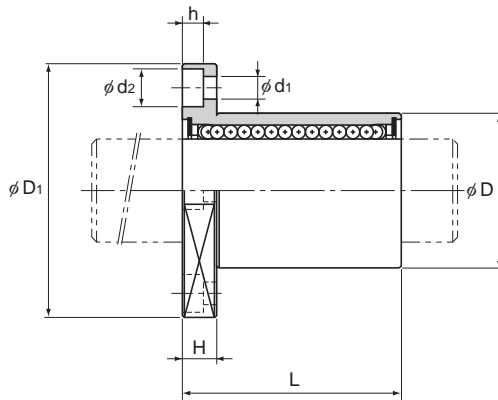

Unit: mm

	K	H	PCD	Mounting hole $d_1 \times d_2 \times h$	Flange perpendicularity	Eccentricity (max)	Radial clearance tolerance	Basic load rating		Mass g
					μm	μm	μm	C N	C_0 N	
	22	5	20	$3.4 \times 6.5 \times 3.3$	12	12	-5	206	265	18.5
	25	5	24	$3.4 \times 6.5 \times 3.3$	12	12	-5	176	225	23
	25	5	24	$3.4 \times 6.5 \times 3.3$	12	12	-5	265	402	29
	30	6	29	$4.5 \times 8 \times 4.4$	12	12	-5	373	549	61
	32	6	32	$4.5 \times 8 \times 4.4$	12	12	-5	412	598	56
	34	6	33	$4.5 \times 8 \times 4.4$	12	12	-7	510	775	75
	37	6	38	$4.5 \times 8 \times 4.4$	12	12	-7	775	1180	104
	42	8	43	$5.5 \times 9.2 \times 5.4$	15	15	-9	863	1370	145
	50	8	51	$5.5 \times 9.2 \times 5.4$	15	15	-9	980	1570	300
	58	10	60	$6.6 \times 11 \times 6.5$	15	15	-9	1570	2750	375

Note) Since the nut and the balls use stainless steel, these models are highly resistant to corrosion and environment.
If an oil hole is required, this can be indicated by appending "OH" to the end of the model number.
For further information, contact THK.

Model LMK-L

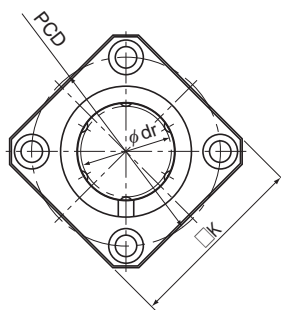

Model LMK-L

Model No.	Ball rows	Main dimensions							
		Inscribed bore diameter		Outer diameter		Length		Flange diameter	
		dr	Tolerance	D	Tolerance	L	Tolerance	D ₁	Tolerance
LMK 6L	4	6	0 -0.010	12	0	35	0 -0.3	28	0 -0.2
LMK 8L	4	8		15	-0.013	45		32	
LMK 10L	4	10		19	0 -0.016	55		39	
LMK 12L	4	12		21		57		42	
LMK 13L	4	13	23	0 -0.012	61	43			
LMK 16L	5	16	28		70	48			
LMK 20L	5	20	32	0	80	54			
LMK 25L	6	25	40	-0.019	112	62			
LMK 30L	6	30	45	0 -0.015	123	74			
LMK 35L	6	35	52		135	82			
LMK 40L	6	40	60		0	154	96		
LMK 50L	6	50	80		-0.022	192	116		
LMK 60L	6	60	0	90	0	211	134	0 -0.3	

Note) Since this model contains a synthetic resin retainer, do not use it at temperature exceeding 80°C.
If requiring a type equipped with a seal, indicate it when placing an order.

(Example) LMK50L UU

└─── Seal attached on both ends of the nut

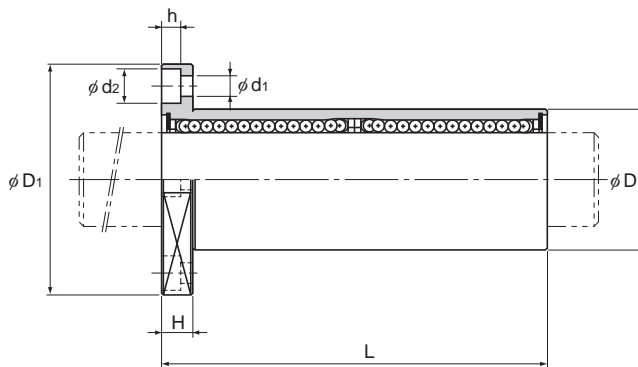

Unit: mm

	K	H	PCD	Mounting hole $d_1 \times d_2 \times h$	Flange perpendicularity	Eccentricity (max)	Radial clearance tolerance	Basic load rating		Mass g
					μm	μm	μm	C N	C_0 N	
	22	5	20	$3.4 \times 6.5 \times 3.3$	15	15	-5	324	529	26
	25	5	24	$3.4 \times 6.5 \times 3.3$	15	15	-5	431	784	46
	30	6	29	$4.5 \times 8 \times 4.4$	15	15	-5	588	1100	88
	32	6	32	$4.5 \times 8 \times 4.4$	15	15	-5	657	1200	82
	34	6	33	$4.5 \times 8 \times 4.4$	15	15	-7	814	1570	108
	37	6	38	$4.5 \times 8 \times 4.4$	15	15	-7	1230	2350	160
	42	8	43	$5.5 \times 9.2 \times 5.4$	20	20	-9	1400	2750	230
	50	8	51	$5.5 \times 9.2 \times 5.4$	20	20	-9	1560	3140	475
	58	10	60	$6.6 \times 11 \times 6.5$	20	20	-9	2490	5490	575
	64	10	67	$6.6 \times 11 \times 6.5$	25	25	-13	2650	6270	870
	75	13	78	$9 \times 14 \times 8.6$	25	25	-13	3430	8040	1380
	92	13	98	$9 \times 14 \times 8.6$	25	25	-13	6080	15900	3300
	106	18	112	$11 \times 17.5 \times 10.8$	25	25	-13	7650	20000	4060

Note) If an oil hole is required, this can be indicated by appending "OH" to the end of the model number.
For further information, contact THK.

Model LMK-ML (Stainless Steel Type)

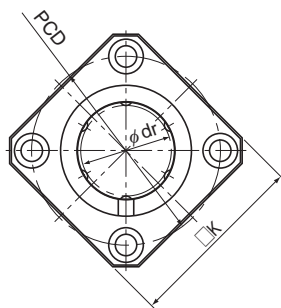

Model LMK-ML

Model No. Standard type	Ball rows	Main dimensions							
		Inscribed bore diameter		Outer diameter		Length		Flange diameter	
		dr	Tolerance	D	Tolerance	L	Tolerance	D ₁	Tolerance
LMK 6ML	4	6	0 -0.010	12	0	35	0 -0.3	28	0 -0.2
LMK 8ML	4	8		15	-0.013	45		32	
LMK 10ML	4	10		19	0 -0.016	55		39	
LMK 12ML	4	12		21		57		42	
LMK 13ML	4	13		23		61		43	
LMK 16ML	5	16	28	70	48				
LMK 20ML	5	20	32	0	80	54			
LMK 25ML	6	25	40	0 -0.019	112	0	62		
LMK 30ML	6	30	45		123	-0.4	74		

Note) Since this model contains a synthetic resin retainer, do not use it at temperature exceeding 80°C.
If requiring a type equipped with a seal, indicate it when placing an order.

(Example) LMK8ML UU

└── Seal attached on both ends of the nut

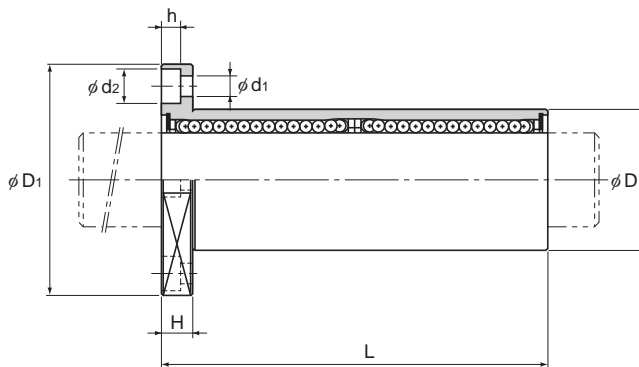

Unit: mm

	K	H	PCD	Mounting hole $d_1 \times d_2 \times h$	Flange perpendicularity	Eccentricity (max)	Radial clearance tolerance	Basic load rating		Mass g
					μm	μm	μm	C N	C_0 N	
	22	5	20	$3.4 \times 6.5 \times 3.3$	15	15	-5	324	529	26
	25	5	24	$3.4 \times 6.5 \times 3.3$	15	15	-5	431	784	46
	30	6	29	$4.5 \times 8 \times 4.4$	15	15	-5	588	1100	88
	32	6	32	$4.5 \times 8 \times 4.4$	15	15	-5	657	1200	82
	34	6	33	$4.5 \times 8 \times 4.4$	15	15	-7	814	1570	108
	37	6	38	$4.5 \times 8 \times 4.4$	15	15	-7	1230	2350	160
	42	8	43	$5.5 \times 9.2 \times 5.4$	20	20	-9	1400	2750	230
	50	8	51	$5.5 \times 9.2 \times 5.4$	20	20	-9	1560	3140	475
	58	10	60	$6.6 \times 11 \times 6.5$	20	20	-9	2490	5490	575

Note) Since the nut and the balls use stainless steel, these models are highly resistant to corrosion and environment.
If an oil hole is required, this can be indicated by appending "OH" to the end of the model number.
For further information, contact THK.

Model LMH

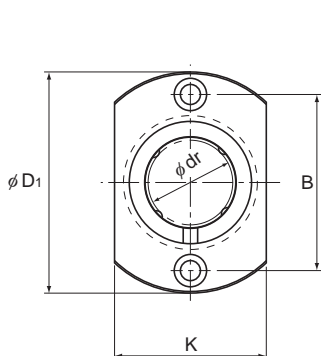

Models LMH6 to 13

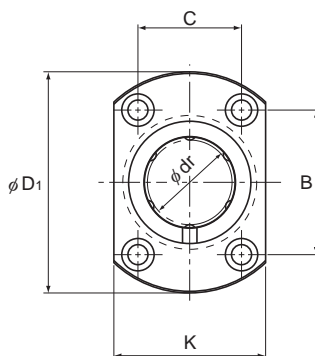

Models LMH16 to 30

Model No.	Ball rows	Main dimensions							
		Inscribed bore diameter		Outer diameter		Length		Flange diameter	
Standard type		dr	Tolerance	D	Tolerance	L	Tolerance	D ₁	Tolerance
LMH 6	4	6	0 -0.009	12	0	19	0 -0.2	28	0 -0.2
LMH 8	4	8		15	-0.011	24		32	
LMH 10	4	10		19	29	39			
LMH 12	4	12		21	0	30		42	
LMH 13	4	13	23	-0.013	32	43			
LMH 16	5	16	28	37	48				
LMH 20	5	20	32	0	42	54			
LMH 25	6	25	40	-0.016	59	0	62		
LMH 30	6	30	45	64	-0.3	74			

Note) Since this model contains a synthetic resin retainer, do not use it at temperature exceeding 80°C.
If requiring a type equipped with a seal, indicate it when placing an order.

(Example) LMH16 UU

└─── Seal attached on both ends of the nut

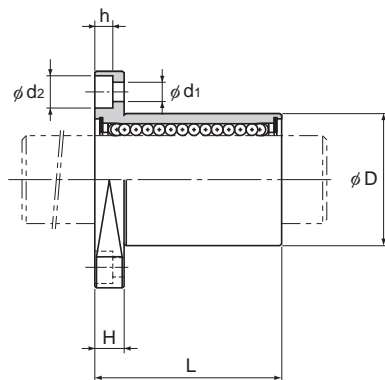

Unit: mm

	K	H	B	C	Mounting hole d ₁ × d ₂ × h	Flange perpendicularity	Eccentricity (max)	Radial clearance tolerance	Basic load rating		Mass g
						μm	μm	μm	C N	C ₀ N	
	18	5	20	—	3.4 × 6.5 × 3.3	12	12	-5	206	265	18
	21	5	24	—	3.4 × 6.5 × 3.3	12	12	-5	265	402	28
	25	6	29	—	4.5 × 8 × 4.4	12	12	-5	373	549	50
	27	6	32	—	4.5 × 8 × 4.4	12	12	-5	412	598	55
	29	6	33	—	4.5 × 8 × 4.4	12	12	-7	510	775	70
	34	6	31	22	4.5 × 8 × 4.4	12	12	-7	775	1180	95
	38	8	36	24	5.5 × 9.2 × 5.4	15	15	-9	863	1370	150
	46	8	40	32	5.5 × 9.2 × 5.4	15	15	-9	980	1570	275
	51	10	49	35	6.6 × 11 × 6.5	15	15	-9	1570	2750	350

Note) If an oil hole is required, this can be indicated by appending "OH" to the end of the model number.
For further information, contact THK.

Model LMH-L

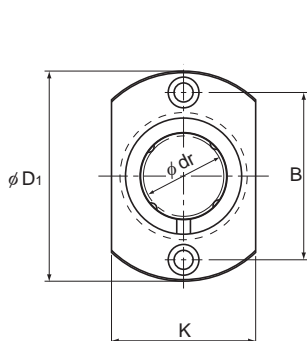

Models LMH6L to 13L

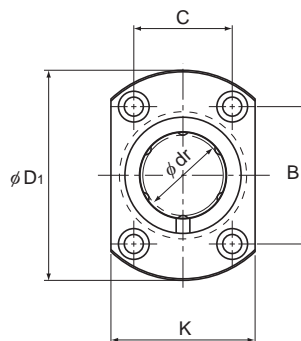

Models LMH16L to 30L

Model No.	Ball rows	Main dimensions							
		Inscribed bore diameter		Outer diameter		Length		Flange diameter	
Standard type		dr	Tolerance	D	Tolerance	L	Tolerance	D ₁	Tolerance
LMH 6L	4	6	0 -0.010	12	0	35	0 -0.3	28	0 -0.2
LMH 8L	4	8		15	-0.013	45		32	
LMH 10L	4	10		19	55	39			
LMH 12L	4	12		21	0	57		42	
LMH 13L	4	13		23	-0.016	61		43	
LMH 16L	5	16	28	70	48				
LMH 20L	5	20	32	0	80	54			
LMH 25L	6	25	40	0 -0.019	112	0	62		
LMH 30L	6	30	45		123	-0.4	74		

Note) Since this model contains a synthetic resin retainer, do not use it at temperature exceeding 80°C.
If requiring a type equipped with a seal, indicate it when placing an order.

(Example) LMH20L UU

Seal attached on both ends of the nut

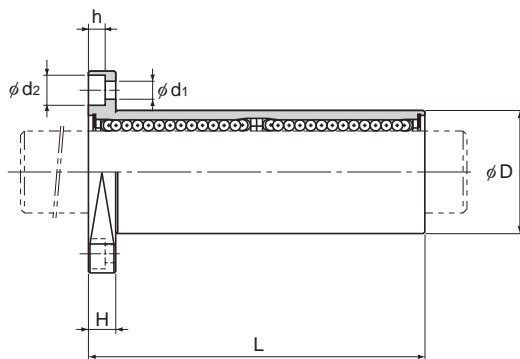

Unit: mm

	K	H	B	C	Mounting hole $d_1 \times d_2 \times h$	Flange perpendicularity	Eccentricity (max)	Radial clearance tolerance	Basic load rating		Mass g
						μm	μm	μm	C N	C_0 N	
	18	5	20	—	$3.4 \times 6.5 \times 3.3$	15	15	-5	324	529	28
	21	5	24	—	$3.4 \times 6.5 \times 3.3$	15	15	-5	431	784	40
	25	6	29	—	$4.5 \times 8 \times 4.4$	15	15	-5	588	1100	75
	27	6	32	—	$4.5 \times 8 \times 4.4$	15	15	-5	657	1200	82
	29	6	33	—	$4.5 \times 8 \times 4.4$	15	15	-7	814	1570	107
	34	6	31	22	$4.5 \times 8 \times 4.4$	15	15	-7	1230	2350	143
	38	8	36	24	$5.5 \times 9.2 \times 5.4$	20	20	-9	1400	2750	225
	46	8	40	32	$5.5 \times 9.2 \times 5.4$	20	20	-9	1560	3140	450
	51	10	49	35	$6.6 \times 11 \times 6.5$	20	20	-9	2490	5490	575

Note) If an oil hole is required, this can be indicated by appending "OH" to the end of the model number.
For further information, contact THK.

Model LMIF

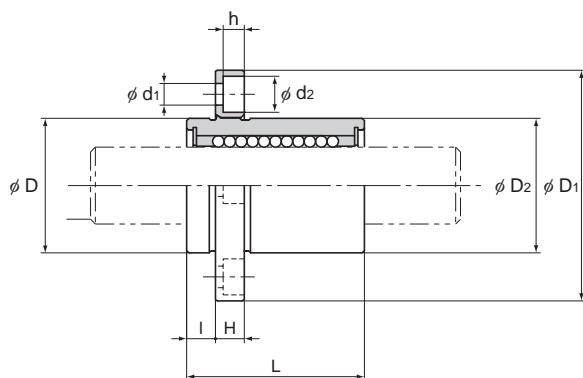

Model LMIF

Model No.	Ball rows	Main dimensions							
		Inscribed bore diameter		Outer diameter		Overall length		Flange diameter	
		dr	Tolerance	D	Tolerance	L	Tolerance	D ₁	Tolerance
LMIF 6	4	6	0 -0.009	12	0	19	±0.3	28	0 -0.2
LMIF 8		8		15	-0.011	24		32	
LMIF 10		10		19	29	39			
LMIF 12		12		21	0	30		42	
LMIF 13		13		23	-0.013	32		43	
LMIF 16	5	16	0 -0.010	28	0 -0.016	37	±0.3	48	0 -0.2
LMIF 20		20		32		42		54	
LMIF 25		25		40		59		62	

Note) Since this model contains a synthetic resin retainer, do not use it at temperature exceeding 80°C.
If requiring a type equipped with a seal, indicate it when placing an order.

(Example) LMIF16 UU

└── Seal attached on both ends of the nut

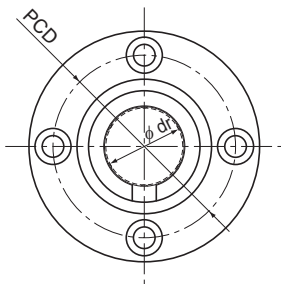

Unit: mm

	Length		D ₂	H	PCD	Mounting hole d ₁ × d ₂ × h	Flange	Eccentricity (max) μm	Radial clearance tolerance μm	Basic Load Rating		Mass g
	l	Tolerance					perpendicularity μm			C	C ₀	
5		±0.2	12	5	20	3.4 × 6 × 3.3	12	12	-5	206	265	24
			15		24		12		-5	265	402	34
6		±0.2	19	6	29	4.5 × 7.5 × 4.4	12	12	-5	373	549	61
			21		32		12		-5	412	598	69
			23		33		12		-7	510	775	81
			28		38		12		-7	775	1180	125
8		±0.2	32	8	43	5.5 × 9 × 5.4	15	15	-9	863	1370	166
			40		51		15		-9	980	1570	305

Note) If an oil hole is required, this can be indicated by appending "OH" to the end of the model number.
For further information, contact THK.

Model LMIF-L

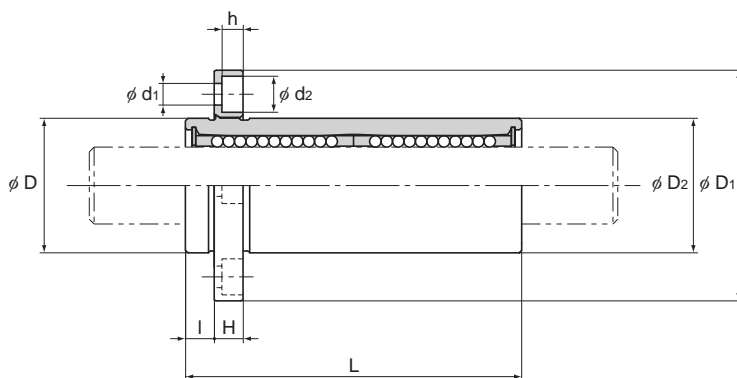

Model LMIF-L

Model No.	Ball rows	Main dimensions							
		Inscribed bore diameter		Outer diameter		Overall length		Flange diameter	
		dr	Tolerance	D	Tolerance	L	Tolerance	D ₁	Tolerance
LMIF 6L	4	6	0 -0.010	12	0	35	±0.3	28	0 -0.2
LMIF 8L		8		15	-0.013	45		32	
LMIF 10L		10		19	0 -0.016	55		39	
LMIF 12L		12		21		57		42	
LMIF 13L	5	13	0 -0.012	23	0 -0.019	61	±0.3	43	0 -0.2
LMIF 16L		16		28		70		48	
LMIF 20L		20		32		80		54	
LMIF 25L		25		40		112		62	

Note) Since this model contains a synthetic resin retainer, do not use it at temperature exceeding 80°C.
If requiring a type equipped with a seal, indicate it when placing an order.

(Example) LMIF16L UU

└── Seal attached on both ends of the nut

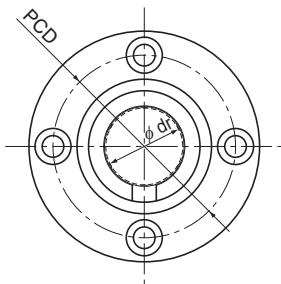

Unit: mm

	Length		D ₂	H	PCD	Mounting hole d ₁ × d ₂ × h	Flange	Eccentricity (max) μm	Radial clearance tolerance μm	Basic Load Rating		Mass g
	l	Tolerance					perpendicularity μm			C	C ₀	
5		±0.2	12	5	20	3.4 × 6 × 3.3	12	12	-5	324	529	30
			15		24		12		-5	431	784	46
6		±0.2	19	6	29	4.5 × 7.5 × 4.4	12	12	-5	588	1100	83
			21		32		12		-5	657	1200	95
			23		33		12		-7	814	1570	117
			28		38		12		-7	1230	2350	196
8		±0.2	32	8	43	5.5 × 9 × 5.4	15	15	-9	1400	2750	244
			40		51		15		-9	1560	3140	498

Note) If an oil hole is required, this can be indicated by appending "OH" to the end of the model number.
For further information, contact THK.

Model LMCF-L

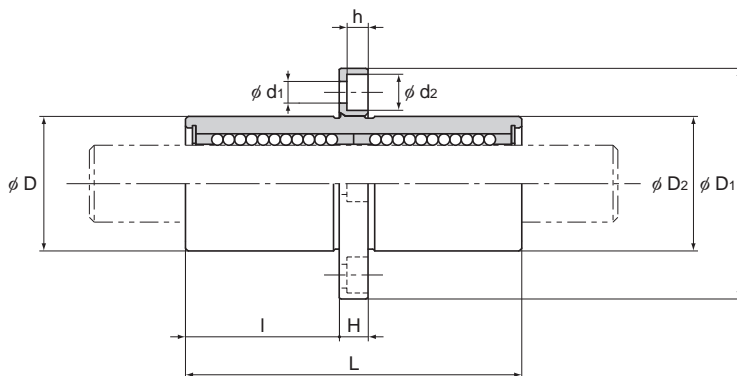

Model LMCF-L

Model No.	Ball rows	Main dimensions							
		Inscribed bore diameter		Outer diameter		Overall length		Flange diameter	
		dr	Tolerance	D	Tolerance	L	Tolerance	D ₁	Tolerance
LMCF 6L	4	6	0 -0.010	12	0	35	±0.3	28	0 -0.2
LMCF 8L		8		15	-0.013	45		32	
LMCF 10L		10		19	55	39			
LMCF 12L		12		21	0	57		42	
LMCF 13L		13		23	-0.016	61		43	
LMCF 16L	5	16	0 -0.012	28	0	70	48		
LMCF 20L		20		32	0	80	54		
LMCF 25L		25		40	-0.019	112	62		

Note) Since this model contains a synthetic resin retainer, do not use it at temperature exceeding 80°C.
If requiring a type equipped with a seal, indicate it when placing an order.

(Example) LMCF16L UU

└ Seal attached on both ends of the nut

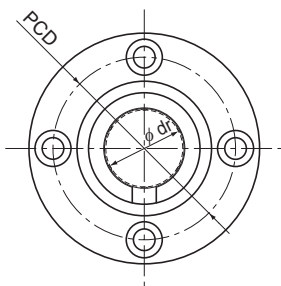

Unit: mm

	Length		D ₂	H	PCD	Mounting hole d ₁ × d ₂ × h	Flange	Eccentricity (max) μm	Radial clearance tolerance μm	Basic Load Rating		Mass g
	l	Tolerance					perpendicularity μm			C	C ₀	
	15	±0.2	12	5	20	3.4 × 6 × 3.3	12	12	-5	324	529	30
	20		15		24		12		-5	431	784	46
	24.5		19		29	12	-5		588	1100	83	
	25.5		21	6	32	4.5 × 7.5 × 4.4	12		-5	657	1200	95
	27.5		23		33		12		-7	814	1570	117
	32		28		38		12		-7	1230	2350	196
	36		32		8		43	5.5 × 9 × 5.4	15	-9	1400	2750
	52		40	51		15	-9		1560	3140	498	

Note) If an oil hole is required, this can be indicated by appending "OH" to the end of the model number.
For further information, contact THK.

Model LMIK

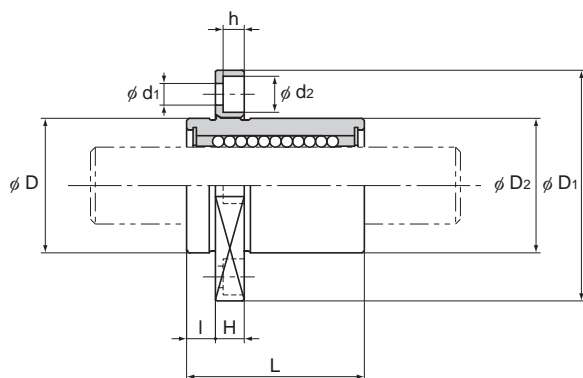

Model LMIK

Model No.	Ball rows	Main dimensions							
		Inscribed bore diameter		Outer diameter		Overall length		Flange diameter	
		dr	Tolerance	D	Tolerance	L	Tolerance	D ₁	Tolerance
LMIK 6	4	6	0 -0.009	12	0	19	±0.3	28	0 -0.2
LMIK 8		8		15	-0.011	24		32	
LMIK 10		10		19	29	39			
LMIK 12		12		21	0	30		42	
LMIK 13		13		23	-0.013	32		43	
LMIK 16	5	16	0 -0.010	28	0 -0.016	37	±0.3	48	0 -0.2
LMIK 20		20		32		42		54	
LMIK 25		25		40		59		62	

Note) Since this model contains a synthetic resin retainer, do not use it at temperature exceeding 80°C.
If requiring a type equipped with a seal, indicate it when placing an order.

(Example) LMIK16 UU

└ Seal attached on both ends of the nut

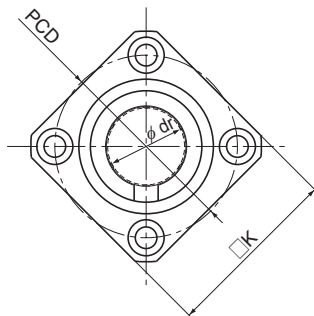

Unit: mm

	Length		D ₂	H	K	PCD	Mounting hole d ₁ × d ₂ × h	Flange	Eccentricity (max) μm	Radial clearance tolerance μm	Basic Load Rating		Mass g	
	l	Tolerance						perpendicularity μm			C	C ₀		
5		±0.2	12	5	22	20	3.4 × 6 × 3.3	12	12	-5	206	265	18	
			15		25	24		12			-5	265	402	27
6		±0.2	19	6	30	29	4.5 × 7.5 × 4.4	12	12	-5	373	549	46	
			21		32	32		12			-5	412	598	52
			23		34	33		12			-7	510	775	65
			28		37	38		12			-7	775	1180	104
8		±0.2	32	8	42	43	5.5 × 9 × 5.4	15	15	-9	863	1370	131	
			40		50	51		15			-9	980	1570	267

Note) If an oil hole is required, this can be indicated by appending "OH" to the end of the model number.
For further information, contact THK.

Model LMIK-L

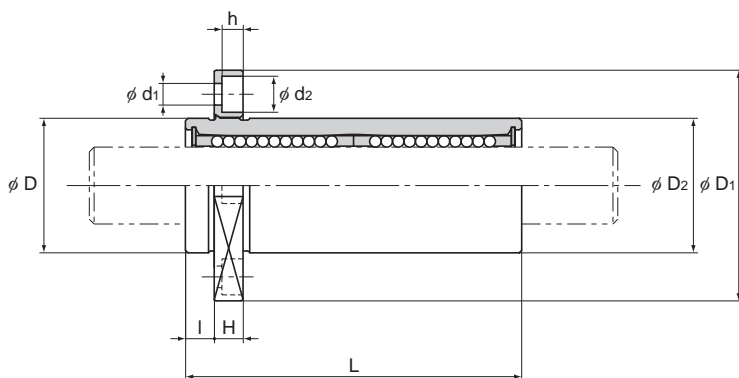

Model LMIK-L

Model No.	Ball rows	Main dimensions											
		Inscribed bore diameter		Outer diameter		Overall length		Flange diameter					
		dr	Tolerance	D	Tolerance	L	Tolerance	D ₁	Tolerance				
LMIK 6L	4	6	0	12	0	35	±0.3	28	0				
LMIK 8L		8		15	-0.013	45		32					
LMIK 10L		10		19	-0.016	55		39					
LMIK 12L		12		21		57		42					
LMIK 13L	5	13	0	23	-0.016	61	±0.3	43	-0.2				
LMIK 16L		16		28		70		48					
LMIK 20L		20		32		80		54					
LMIK 25L		6		25		-0.012		40		-0.019	112	±0.3	62

Note) Since this model contains a synthetic resin retainer, do not use it at temperature exceeding 80°C.
If requiring a type equipped with a seal, indicate it when placing an order.

(Example) LMIK16L UU

└ Seal attached on both ends of the nut

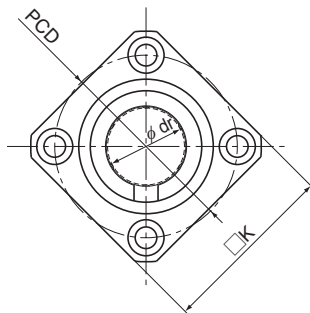

Unit: mm

	Length		D ₂	H	K	PCD	Mounting hole d ₁ × d ₂ × h	Flange	Eccentricity (max)	Radial clearance tolerance	Basic Load Rating		Mass	
	l	Tolerance						perpendicularity			μm	μm		C
5		±0.2	12	5	22	20	3.4 × 6 × 3.3	12	12	-5	324	529	25	
			15		25	24		12			-5	431	784	39
6		±0.2	19	6	30	29	4.5 × 7.5 × 4.4	12	12	-5	588	1100	69	
			21		32	32		12			-5	657	1200	78
			23		34	33		12			-7	814	1570	101
			28		37	38		12			-7	1230	2350	174
8		±0.2	32	8	42	43	5.5 × 9 × 5.4	15	15	-9	1400	2750	210	
			40		50	51		15			-9	1560	3140	461

Note) If an oil hole is required, this can be indicated by appending "OH" to the end of the model number.
For further information, contact THK.

Model LMCK-L

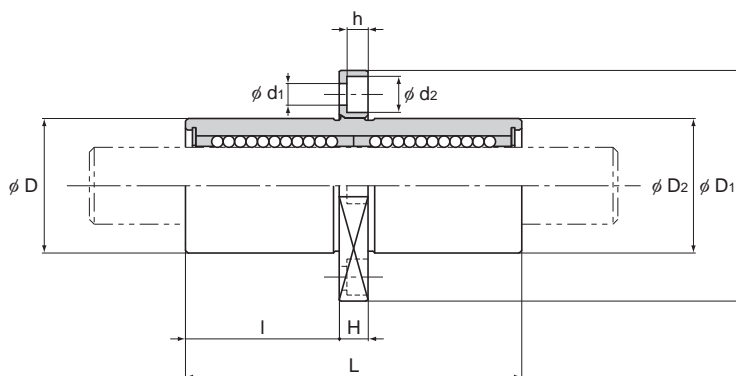

Model LMCK-L

Model No.	Ball rows	Main dimensions							
		Inscribed bore diameter		Outer diameter		Overall length		Flange diameter	
		dr	Tolerance	D	Tolerance	L	Tolerance	D ₁	Tolerance
LMCK 6L	4	6	0 -0.010	12	0	35	±0.3	28	0 -0.2
LMCK 8L		8		15	-0.013	45		32	
LMCK 10L		10		19	55	39			
LMCK 12L		12		21	0	57		42	
LMCK 13L		13		23	-0.016	61		43	
LMCK 16L	5	16	0	28	0	70	±0.3	48	0 -0.2
LMCK 20L		20		32		80		54	
LMCK 25L		25		-0.012		40		-0.019	

Note) Since this model contains a synthetic resin retainer, do not use it at temperature exceeding 80°C.
If requiring a type equipped with a seal, indicate it when placing an order.

(Example) LMCK16L UU

└── Seal attached on both ends of the nut

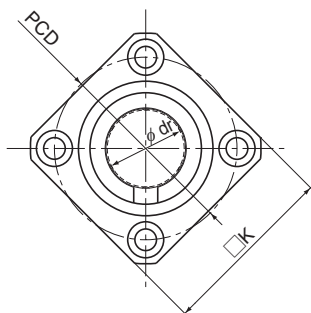

Unit: mm

								Flange perpendicularity	Eccentricity (max)	Radial clearance tolerance	Basic Load Rating		Mass
Length		D ₂	H	K	PCD	Mounting hole d ₁ × d ₂ × h	μm				μm	C	
I	Tolerance												
15	±0.2	12	5	22	20	3.4 × 6 × 3.3	12	12	-5	324	529	25	
20		15		25	24		12		-5	431	784	39	
24.5		19	30	29	12	-5	588		1100	69			
25.5		21	6	32	32	12	-5		657	1200	78		
27.5		23	34	33	12	-7	814	1570	101				
32		28	37	38	12	-7	1230	2350	174				
36		32	8	42	43	15	-9	1400	2750	210			
52		40	50	51	5.5 × 9 × 5.4	15	-9	1560	3140	461			

Note) If an oil hole is required, this can be indicated by appending "OH" to the end of the model number.
For further information, contact THK.

Model LMIH

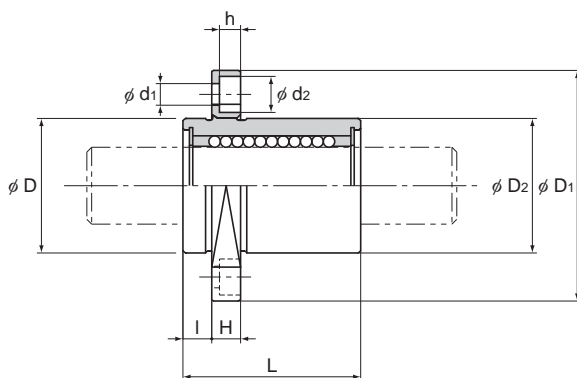

Model LMIH

Model No.	Ball rows	Main dimensions							
		Inscribed bore diameter		Outer diameter		Overall length		Flange diameter	
		dr	Tolerance	D	Tolerance	L	Tolerance	D ₁	Tolerance
LMIH 6	4	6	0 -0.009	12	0	19	±0.3	28	0 -0.2
LMIH 8		8		15	-0.011	24		32	
LMIH 10		10		19	29	39			
LMIH 12		12		21	0	30		42	
LMIH 13		13		23	-0.013	32		43	
LMIH 16	5	16	0 -0.010	28	0 -0.016	37	±0.3	48	0 -0.2
LMIH 20		20		32		42		54	
LMIH 25		25		40		59		62	

Note) Since this model contains a synthetic resin retainer, do not use it at temperature exceeding 80°C.
If requiring a type equipped with a seal, indicate it when placing an order.

(Example) LMIH16 UU

└ Seal attached on both ends of the nut

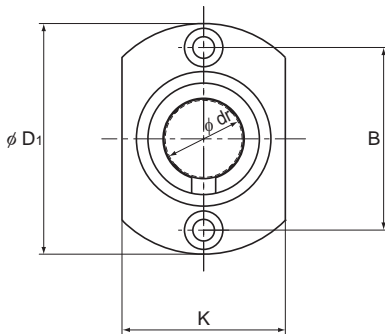

Models LMIH 6 to 13

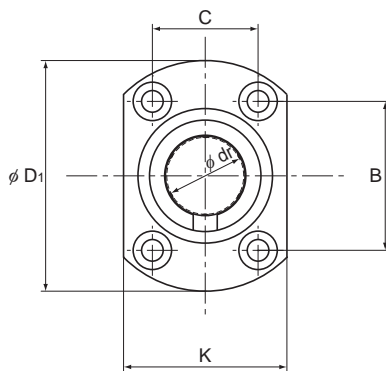

Models LMIH 16 to 25

Unit: mm

	Length		D ₂	H	K	B	C	Mounting hole d ₁ × d ₂ × h	Flange perpendicularity μm	Eccentricity (max) μm	Radial clearance tolerance μm	Basic Load Rating		Mass g	
	I	Tolerance										C	C ₀		
5		±0.2	12	5	18	20	—	3.4 × 6 × 3.3	12	12	-5	206	265	20	
			15		21	24	—		12			-5	265	402	29
6		±0.2	19	6	25	29	—	4.5 × 7.5 × 4.4	12	12	-5	373	549	50	
			21		27	32	—		12			-5	412	598	57
			23		29	33	—		12			-7	510	775	70
			28		34	31	22		12			-7	775	1180	111
8		±0.2	32	8	38	36	24	5.5 × 9 × 5.4	15	15	-9	863	1370	140	
			40		46	40	32		15			-9	980	1570	276

Note) If an oil hole is required, this can be indicated by appending "OH" to the end of the model number.
For further information, contact THK.

Model LMIH-L

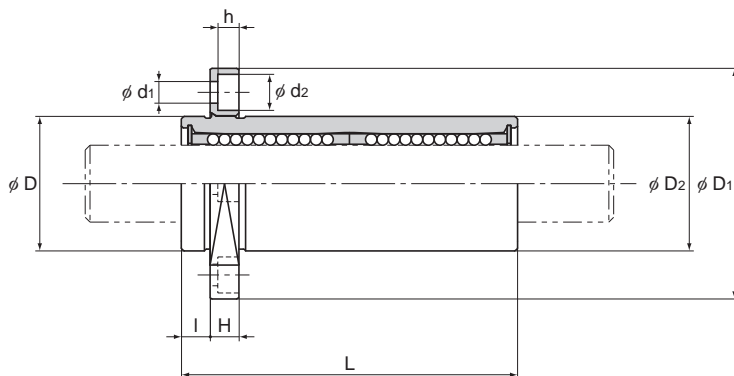

Model LMIH-L

Model No.	Ball rows	Main dimensions							
		Inscribed bore diameter		Outer diameter		Overall length		Flange diameter	
		dr	Tolerance	D	Tolerance	L	Tolerance	D ₁	Tolerance
LMIH 6L	4	6	0 -0.010	12	0	35	±0.3	28	0 -0.2
LMIH 8L		8		15	-0.013	45		32	
LMIH 10L		10		19	55	39			
LMIH 12L		12		21	0	57		42	
LMIH 13L		13		23	-0.016	61		43	
LMIH 16L	5	16	0 -0.012	28	0	70	±0.3	48	0 -0.2
LMIH 20L		20		32	0	80		54	
LMIH 25L		25		40	-0.019	112		62	

Note) Since this model contains a synthetic resin retainer, do not use it at temperature exceeding 80°C.
If requiring a type equipped with a seal, indicate it when placing an order.

(Example) LMIH16L UU

└ Seal attached on both ends of the nut

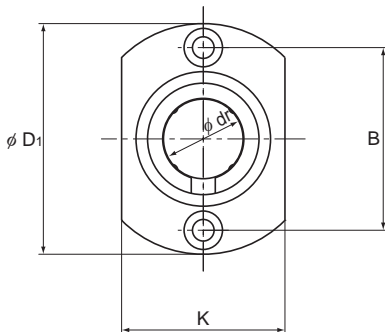

Models LMIH 6L to 13L

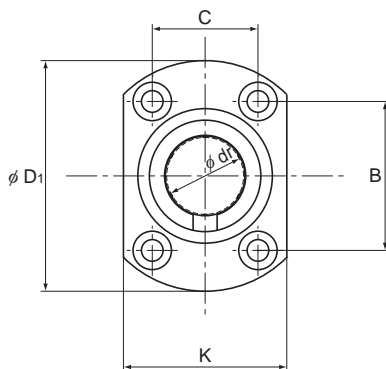

Models LMIH 16L to 25L

Unit: mm

	Length		D ₂	H	K	B	C	Mounting hole d ₁ × d ₂ × h	Flange perpendicularity μm	Eccentricity (max) μm	Radial clearance tolerance μm	Basic Load Rating		Mass g	
	I	Tolerance										C	C ₀		
5		±0.2	12	5	18	20	—	3.4 × 6 × 3.3	12	12	-5	324	529	26	
			15		21	24	—		12			-5	431	784	41
6		±0.2	19	6	25	29	—	4.5 × 7.5 × 4.4	12	12	-5	588	1100	73	
			21		27	32	—		12			-5	657	1200	83
			23		29	33	—		12			-7	814	1570	106
			28		34	31	22		12			-7	1230	2350	180
8		±0.2	32	8	38	36	24	5.5 × 9 × 5.4	15	15	-9	1400	2750	219	
			40		46	40	32		15			-9	1560	3140	470

Note) If an oil hole is required, this can be indicated by appending "OH" to the end of the model number.
For further information, contact THK.

Model LMCH-L

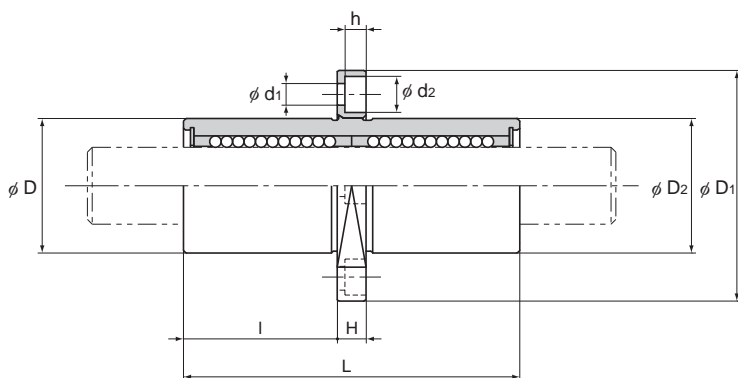

Model LMCH-L

Model No.	Ball rows	Main dimensions								
		Inscribed bore diameter		Outer diameter		Overall length		Flange diameter		
		dr	Tolerance	D	Tolerance	L	Tolerance	D ₁	Tolerance	
LMCH 6L	4	6	0 -0.010	12	0	35	±0.3	28	0 -0.2	
LMCH 8L		8		15	-0.013	45		32		
LMCH 10L		10		19	-0.016	55		39		
LMCH 12L		12		21		0		57		42
LMCH 13L		13		23		0		61		43
LMCH 16L	5	16	0 -0.012	28	0	70	±0.3	48	0 -0.2	
LMCH 20L		20		32	0	80		54		
LMCH 25L		25		40	-0.019	112		62		

Note) Since this model contains a synthetic resin retainer, do not use it at temperature exceeding 80°C.
If requiring a type equipped with a seal, indicate it when placing an order.

(Example) LMCH16L UU

_____ Seal attached on both ends of the nut

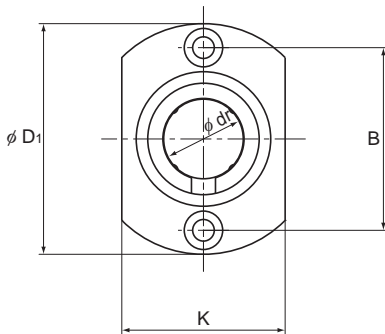

Models LMCH 6L to 13L

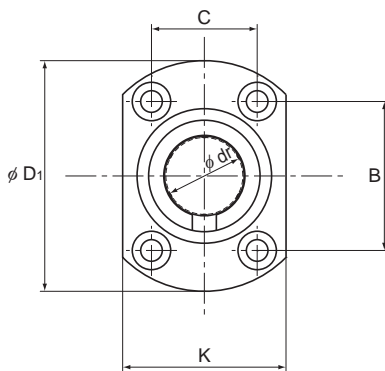

Models LMCH 16L to 25L

Unit: mm

								Flange perpendicularity	Eccentricity (max)	Radial clearance tolerance	Basic Load Rating		Mass	
Length		D ₂	H	K	B	C	Mounting hole d ₁ × d ₂ × h				μm	μm		μm
I	Tolerance							N	N					
15	±0.2	12	5	18	20	—	3.4 × 6 × 3.3	12	12	-5	324	529	26	
20		15		21	24	—		12		-5	431	784	41	
24.5		19		25	29	—	12	-5		588	1100	73		
25.5		6	21	27	32	—	4.5 × 7.5 × 4.4	12		-5	657	1200	83	
27.5			23	29	33	—		12		-7	814	1570	106	
32			28	34	31	22		12		-7	1230	2350	180	
36		8	32	38	36	24	5.5 × 9 × 5.4	15		15	-9	1400	2750	219
52			40	46	40	32		15			-9	1560	3140	470

Note) If an oil hole is required, this can be indicated by appending "OH" to the end of the model number.
For further information, contact THK.

Models SC6 to 30

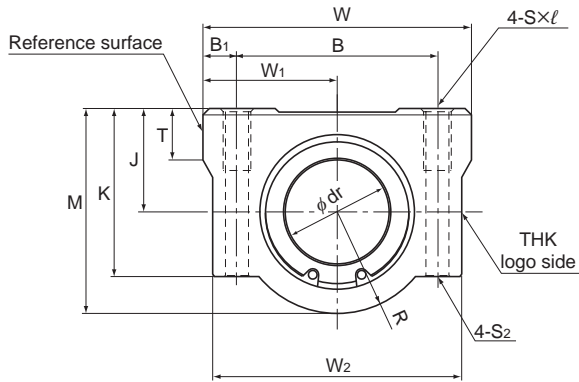

Models SC6 to 30

Model No.	Outer dimensions			LM casing dimensions						
	Height M	Width W	Length L	Mounting hole position			Tap S × l	Through bolt model No. S ₂	Center height J ±0.02	W ₁ ±0.02
				B	B ₁	C				
SC 6UU	18	30	25	20	5	15	M4 × 8	M3	9	15
SC 8UU	22	34	30	24	5	18	M4 × 8	M3	11	17
SC 10UU	26	40	35	28	6	21	M5 × 12	M4	13	20
SC 12UU	29	42	36	30.5	5.75	26	M5 × 12	M4	15	21
SC 13UU	30	44	39	33	5.5	26	M5 × 12	M4	15	22
SC 16UU	38.5	50	44	36	7	34	M5 × 12	M4	19	25
SC 20UU	42	54	50	40	7	40	M6 × 12	M5	21	27
SC 25UU	51.5	76	67	54	11	50	M8 × 18	M6	26	38
SC 30UU	59.5	78	72	58	10	58	M8 × 18	M6	30	39

Note) Since this model contains a synthetic resin retainer, do not use it at temperature exceeding 80°C.

A stainless steel Linear Bushing model LM-MG, which is highly corrosion resistant, can also be incorporated at your request.

Example of Model Number for Use in Combination with
Linear Bushing Units

Linear Bushing to be combined	Example of model No.	
Both end attached with seal	SC 13UU	Standard stock
Without seal	SC 13	Build to order
Made of stainless steel; both end attached with seal	SC 13MUU	Build to order

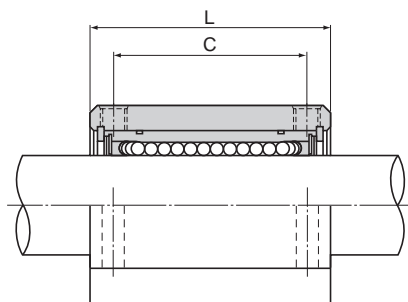

Unit: mm

							Model No. of Linear Bushing to be combined	Basic load rating		Unit
					Inscribed bore diameter			C	C ₀	Mass g
K	W ₂	T	R	dr	Tolerance	N		N		
15	28	6	9	6	0 -0.009	LM6UU	206	265	34	
18	32	6	11	8		LM8UU	265	402	52	
22	37	8	13	10		LM10UU	373	549	92	
25	39	8	14	12		LM12UU	412	598	102	
26	41	8	15	13		LM13UU	510	775	123	
35	46	9	19.5	16		LM16UU	775	1180	189	
36	52	11	21	20	0 -0.010	LM20UU	863	1370	237	
41	68	12	25.5	25		LM25UU	980	1570	555	
49	72	15	29.5	30		LM30UU	1570	2750	685	

Note) If an oil hole is required, this can be indicated by appending "OH" to the end of the model number.
For further information, contact THK.

Models SC35 to 50

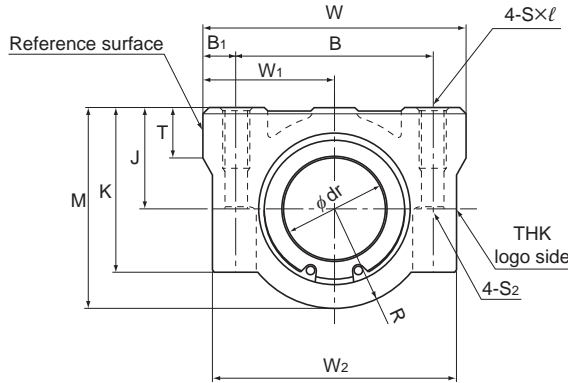

Models SC35 to 50

Model No.	Outer dimensions			LM casing dimensions							
	Height M	Width W	Length L	Mounting hole position			Tap S×ℓ	Through bolt model No., S ₂	Center height J ±0.02	W ₁ ±0.02	K
				B	B ₁	C					
SC 35UU	68	90	80	70	10	60	M8×18	M6	34	45	54
SC 40UU	78	102	90	80	11	60	M10×25	M8	40	51	62
SC 50UU	102	122	110	100	11	80	M10×25	M8	52	61	80

Note) Since this model contains a synthetic resin retainer, do not use it at temperature exceeding 80°C.

A stainless steel Linear Bushing model LM-MG, which is highly corrosion resistant, can also be incorporated at your request.
(Model SC50 does not include a stainless type.)

Example of Model Number for Use in Combination with
Linear Bushing Units

Linear Bushing to be combined	Example of model No.	
Both end attached with seal	SC 40UU	Standard stock
Without seal	SC 40	Build to order
Made of stainless steel; both end attached with seal	SC 40MUU	Build to order

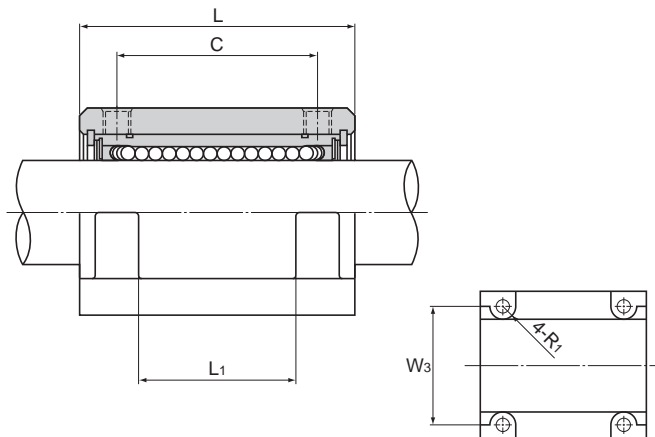

Unit: mm

	W ₂	W ₃	L ₁	T	R	R ₁	Inscribed bore diameter		Model No. of Linear Bushing to be combined	Basic load rating		Unit
							dr	Tolerance		C	C ₀	Mass g
										N	N	
	85	60	42	18	34	5	35	0 -0.012	LM35UU	1670	3140	1100
	96	80	44	20	38	8	40		LM40UU	2160	4020	1600
	116	100	64	25	50	8	50		LM50UU	3820	7940	3350

Note) If an oil hole is required, this can be indicated by appending "OH" to the end of the model number.
For further information, contact THK.

Model SL

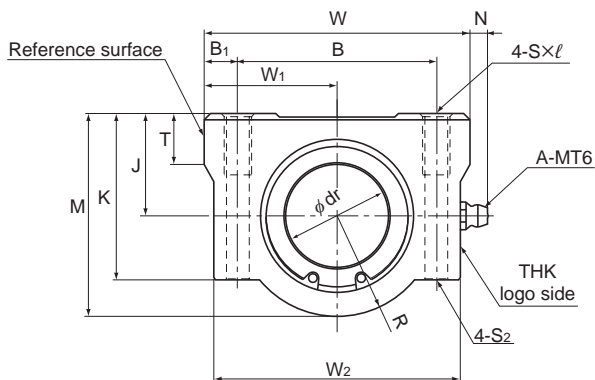

Model SL

Model No.	Outer dimensions			LM casing dimensions						
	Height M	Width W	Length L	Mounting hole position			Tap S × l	Through bolt model No., S ₂	Center height J ±0.02	W ₁ ±0.02
				B	B ₁	C				
SL 6UU	18	30	48	20	5	36	M4 × 8	M3	9	15
SL 8UU	22	34	58	24	5	42	M4 × 8	M3	11	17
SL 10UU	26	40	68	28	6	46	M5 × 12	M4	13	20
SL 12UU	29	42	70	30.5	5.75	50	M5 × 12	M4	15	21
SL 13UU	30	44	75	33	5.5	50	M5 × 12	M4	15	22
SL 16UU	38.5	50	85	36	7	60	M5 × 12	M4	19	25
SL 20UU	42	54	96	40	7	70	M6 × 12	M5	21	27
SL 25UU	51.5	76	130	54	11	100	M8 × 18	M6	26	38
SL 30UU	59.5	78	140	58	10	110	M8 × 18	M6	30	39

Note) Since this model contains a synthetic resin retainer, do not use it at temperature exceeding 80°C.

A stainless steel Linear Bushing model LM-MG, which is highly corrosion resistant, can also be incorporated at your request.

Example of Model Number for Use in Combination with
Linear Bushing Units

Linear Bushing to be combined	Example of model No.	
Both end attached with seal	SL 13UU	Standard stock
Without seal	SL 13	Build to order
Made of stainless steel; both end attached with seal	SL 13MUU	Build to order

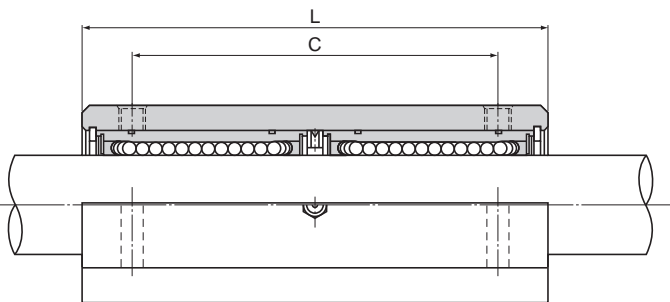

Unit: mm

	K	W ₂	T	R	N	Inscribed bore diameter		Model No. of Linear Bushing to be combined	Basic load rating		Unit
						dr	Tolerance		C	C ₀	Mass
											N
	15	28	6	9	7	6	0 -0.009	LM6U	324	529	68
	18	32	6	11	7	8		LM8U	431	784	105
	22	37	8	13	7	10		LM10U	588	1100	185
	25	39	8	14	6.5	12		LM12U	657	1200	205
	26	41	8	15	6.5	13		LM13U	814	1570	242
	35	46	9	19.5	6	16		LM16U	1230	2350	403
	36	52	11	21	7	20	0 -0.010	LM20U	1400	2750	520
	41	68	12	25.5	4	25		LM25U	1560	3140	1120
	49	72	15	29.5	5	30		LM30U	2490	5490	1440

Note) If an oil hole is required, this can be indicated by appending "OH" to the end of the model number.
For further information, contact THK.

Model SH

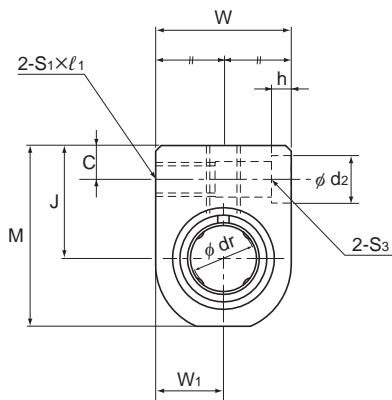

Model SH

Model No.	Outer dimensions			LM casing dimensions					
	Height M	Width W	Length L	Mounting hole position			Tap		Through bolt model No, S ₃
				B	B ₁	C	S ₁ × l ₁	S ₂ × l	
SH 3UU	14	10	13	—	8	3	M3×6	M3×5.5	M2
SH 4UU	16	12	15	—	10	3	M3×6	M3×6	M2
SH 5UU	18	14	17	—	12	3	M3×6	M3×6	M2
SH 6UU	22	16	24	18	9	5	M4×8	M4×8	M3
SH 8UU	26	20	27	20	10	5	M4×8	M5×8.5	M3
SH 10UU	32	26	35	27	15	6	M5×10	M6×9.5	M4
SH 12UU	34	28	35	27	15	6	M5×10	M6×9.5	M4
SH 13UU	36	30	36	28	16	6	M5×10	M6×9.5	M4
SH 16UU	42	36	40	32	18	6	M5×10	M6×10	M4
SH 20UU	49	42	44	36	22	7	M6×12	M6×12	M5

Note) Since this model contains a synthetic resin retainer, do not use it at temperature exceeding 80°C.

A stainless steel Linear Bushing model LM-MG, which is highly corrosion resistant, can also be incorporated at your request.

Example of Model Number for Use in Combination with Linear Bushing Units

Linear Bushing to be combined	Example of model No.	
Both end attached with seal	SH 13UU	Standard stock
Without seal	SH 13	Build to order
Made of stainless steel; both end attached with seal	SH 13MUU	Build to order

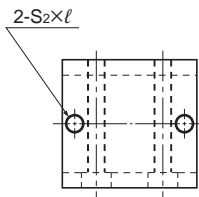
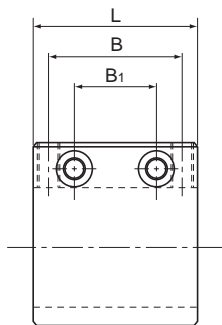

Top surface of models SH6 to SH20

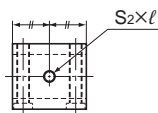

Top surface of models SH3 to SH5

Unit: mm

	Center height J ± 0.02	W_1 ± 0.02	d_2	h	Inscribed bore diameter		Model No. of Linear Bushing to be combined	Basic load rating		Unit	
					dr	Tolerance		C	C_0	Mass	
											N
	9	5	4.2	1.5	3	0 -0.008	LM3UU	88.2	108	4.5	
	10	6	4.2	1.5	4		LM4UU	88.2	127	7	
	11	7	4.2	1.5	5		LM5UU	167	206	11	
	14	8	6.5	3.3	6	0 -0.009	LM6UU	206	265	21.6	
	16	10	6.5	3.3	8		LM8UU	265	402	32	
	19	13	8	4.4	10		LM10UU	373	549	65	
	20	14	8	4.4	12		LM12UU	412	598	81	
	21	15	8	4.4	13		LM13UU	510	775	90	
	24	18	8	4.4	16		LM16UU	775	1180	150	
	28	21	9.5	5.4	20		0 -0.010	LM20UU	863	1370	215

Note) If an oil hole is required, this can be indicated by appending "OH" to the end of the model number.
For further information, contact THK.

Model SH-L

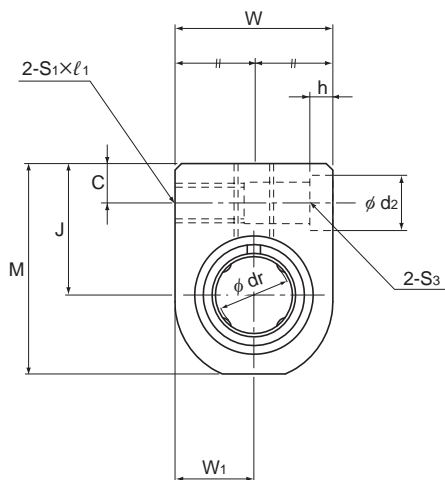

Model SH-L

Model No.	Outer dimensions			LM casing dimensions					
	Height M	Width W	Length L	Mounting hole position			Tap		Through bolt model No, S ₃
				B	B ₁	C	S ₁ × ℓ ₁	S ₂ × ℓ	
SH 3LUU	14	10	23	10	18	3	M3 × 6	M3 × 5.5	M2
SH 4LUU	16	12	27	14	22	3	M3 × 6	M3 × 6	M2
SH 5LUU	18	14	32	18	26	3	M3 × 6	M3 × 6	M2
SH 6LUU	22	16	40	20	30	5	M4 × 8	M4 × 8	M3
SH 8LUU	26	20	52	30	42	5	M4 × 8	M5 × 8.5	M3
SH 10LUU	32	26	60	36	50	6	M5 × 10	M6 × 9.5	M4
SH 12LUU	34	28	62	36	50	6	M5 × 10	M6 × 9.5	M4
SH 13LUU	36	30	66	40	54	6	M5 × 10	M6 × 9.5	M4
SH 16LUU	42	36	76	52	66	6	M5 × 10	M6 × 10	M4
SH 20LUU	49	42	86	58	72	7	M6 × 12	M6 × 12	M5

Note) Since this model contains a synthetic resin retainer, do not use it at temperature exceeding 80°C.

A stainless steel Linear Bushing model LM-MG, which is highly corrosion resistant, can also be incorporated at your request.

Example of Model Number for Use in Combination with Linear Bushing Units

Linear Bushing to be combined	Example of model No.	
Both end attached with seal	SH 13LUU	Standard stock
Without seal	SH 13L	Build to order
Made of stainless steel; both end attached with seal	SH 13MLUU	Build to order

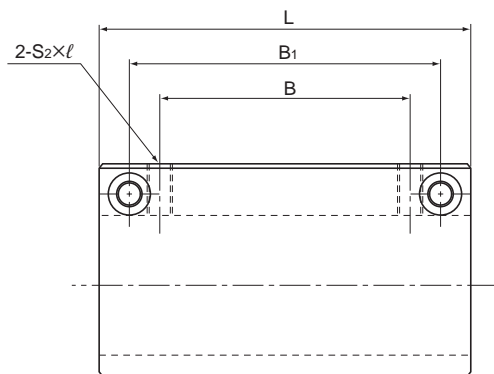

Unit: mm

	Center height J ± 0.02	W_1 ± 0.02	d_2	h	Inscribed bore diameter		Model No. of Linear Bushing to be combined	Basic load rating		Unit
					dr	Tolerance		C	C_0	Mass
	9	5	4.2	1.5	3	0 -0.008	LM3U	139	216	8.5
	10	6	4.2	1.5	4		LM4U	139	254	13
	11	7	4.2	1.5	5		LM5U	263	412	22
	14	8	6.5	3.3	6	0 -0.009	LM6U	324	529	35
	16	10	6.5	3.3	8		LM8U	431	784	65
	19	13	8	4.4	10		LM10U	588	1100	125
	20	14	8	4.4	12		LM12U	657	1200	155
	21	15	8	4.4	13		LM13U	814	1570	190
	24	18	8	4.4	16		LM16U	1230	2350	295
	28	21	9.5	5.4	20	0 -0.010	LM20U	1400	2750	425

Note) If an oil hole is required, this can be indicated by appending "OH" to the end of the model number.
For further information, contact THK.

Model SK

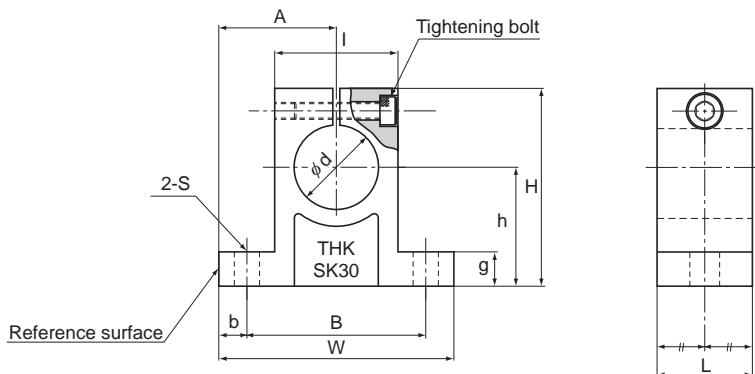

Unit: mm

Model No.	Main dimensions													Mass g
	H	W	L	B	S	Mounting bolt model No.	h ± 0.02	A ± 0.05	b	g	l	Shaft diameter d	Tightening bolt model No.	
SK 10	32.8	42	14	32	5.5	M5	20	21	5	6	18	10	M4	24
SK 12	37.5	42	14	32	5.5	M5	23	21	5	6	20	12	M4	30
SK 13	37.5	42	14	32	5.5	M5	23	21	5	6	20	13	M4	30
SK 16	44	48	16	38	5.5	M5	27	24	5	8	25	16	M4	40
SK 20	51	60	20	45	6.6	M6	31	30	7.5	10	30	20	M5	70
SK 25	60	70	24	56	6.6	M6	35	35	7	12	38	25	M6	130
SK 30	70	84	28	64	9	M8	42	42	10	12	44	30	M6	180
SK 35	83	98	32	74	11	M10	50	49	12	15	50	35	M8	270
SK 40	96	114	36	90	11	M10	60	57	12	15	60	40	M8	420

Dedicated Shafts for Model LM

The LM shaft of the Linear Bushing needs to be manufactured with much consideration for hardness, surface roughness and dimensional accuracy of the shaft since balls roll directly on it. THK manufactures dedicated LM shafts for the Linear Bushing. See the specification table for standard LM shafts on **A4-104**.

Among other factors, the surface hardness of an LM shaft affects the service life of your Linear Bushing system most significantly. Therefore, take much care in selecting a material and a heat treatment method when assembling the system. In addition, as the surface hardness of the LM shaft greatly affects the service life as stated above, use care in selecting and/or handling a material and heat treatment.

[Material]

Generally, the following materials are used for surface hardening through induction-hardening.

- SUJ2 (JIS G 4805: high-carbon chromium bearing steel)
- SK3 to 6 (JIS G 4401: carbon tool steel)
- S55C (JIS G 4051: carbon steel for machine structural use)

For special applications, martensite stainless steel SUS440C, which is corrosion resistant, may also be used.

[Hardness]

We recommend surface hardness of 58 HRC (\approx 653 HV) or higher. The depth of the hardened layer is determined by the size of the Linear Bushing; we recommend approximately 2 mm for general use.

[Surface Roughness]

To achieve smooth motion, the surface should preferably be finished to Ra0.40 or less.

[Dimensions of Hollow LM Shafts]

If a hollow LM shaft is required for purposes such as weight reduction, use the desired material from Table1 for the dimensions of hollow LM shafts that THK keeps in stock.

Models marked with “*” are build-to-order items.

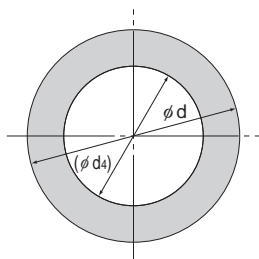

Table1 Dimensions of Hollow LM Shafts Unit: mm

Supported model numbers	LM shaft outer diameter d	Inner diameter (ϕd_i)	Mass (kg/m)	
			Solid shaft	Hollow shaft
LM 8	8	3	0.4	0.34
LM 10	10	4	0.62	0.52
LM 12	12	6	0.89	0.67
LM 13	13	7	1.05	0.75
LM 16	16	9	1.59	1.09
LM 20	20	10	2.47	1.86
LM 20	20	14	2.47	1.26
LM 25	25	15	3.86	2.47
LM 30	30	16	5.56	3.98
LM 35	35	20	7.57	5.1
* LM 38	38	22	8.92	5.93
LM 40	40	22	9.88	6.89
LM 50	50	25	15.5	11.6
LM 60	60	32	22.3	16.0
* LM 80	80	52.5	39.6	22.5
* LM 100	100	67.5	61.8	33.7

Standard LM Shafts

THK manufactures high quality, dedicated LM shafts for Linear Bushing model LM series.

Model number coding

SF25	g6	-500L	K
Model number	LM shaft outer diameter tolerance	Overall LM shaft length (in mm)	Special symbol*
*If two or more symbols are given, they are shown in an alphabetical order. no symbol: solid shaft K: standard hollow shaft M: special material F: with surface treatment			

- [Major materials]
 SUJ2 (high-carbon chromium bearing steel)
 THK5SP (THK standard material)
 SUS440C equivalent
 [Hardness]
 58 to 64 HRC
 [Hardened layer depth]
 0.8 to 2.5mm(varies with shaft diameter)
 [Surface roughness]
 Ra0.20 to Ra0.40
 [Straightness of the LM shaft]
 50 μ m/300 mm or less
- Precision-grade LM shafts with shaft diameter tolerance of g5 or h5 are also manufactured as standard.
- Corrosion resistance, martensite stainless steel LM shafts are also available.
- When asking an estimate or placing an order, refer to the model number coding shown on the left.



Model No.	Shaft diameter		Overall LM shaft length: L mm													Supported model numbers	
	d	Tolerance g6um	100	200	300	400	500	600	700	800	1000	1200	1300	1500	2000		3000
SF 3	3	$^{-2}_{-8}$	◎	◎													LM 3
SF 4	4		◎	◎													LM 4
SF 5	5	-4	◎	◎	◎												LM 5
SF 6	6	-12	◎	◎	◎	◎											LM 6
SF 8	8	-5	◎	◎	◎	◎	◎										LM 8, 8S
SF 10	10	-14	◎	◎	◎	◎	◎	◎	◎								LM 10
SF 12	12			◎	◎	◎	◎	◎		◎	◎						LM 12
SF 13	13	-6	◎	◎	◎	◎	◎	◎	◎	◎							LM 13
SF 16	16	-17	◎	◎	◎	◎	◎	◎	◎	◎	◎						LM 16
SF 20	20			◎	◎	◎	◎	◎	◎	◎	◎	◎	◎				LM 20
SF 25	25	-7		◎	◎	◎	◎	◎	◎	◎	◎	◎	◎				LM 25
SF 30	30	-20			◎	◎	◎	◎	◎	◎	◎	◎	◎	◎			LM 30
SF 35	35						◎	◎		◎	◎	◎		◎	◎		LM 35
SF 38	38	-9						◎			◎	◎			◎		LM 38
SF 40	40	-25					◎	◎	◎	◎	◎	◎	◎	◎	◎	◎	LM 40
SF 50	50						◎	◎		◎	◎	◎	◎	◎	◎	◎	LM 50
SF 60	60	-10									◎	◎			◎	◎	LM 60
SF 80	80	-29									◎	◎			◎	◎	LM 80
SF 100	100	$^{-12}_{-34}$									◎	◎			◎	◎	LM 100

Note) ◎ indicates standard stock; ○ indicates semi-standard stock.

Specially Machined Types

THK also supports special machining processes such as tapping, milling, threading, through hole and end journals, as shown in the Fig.1, at your request.

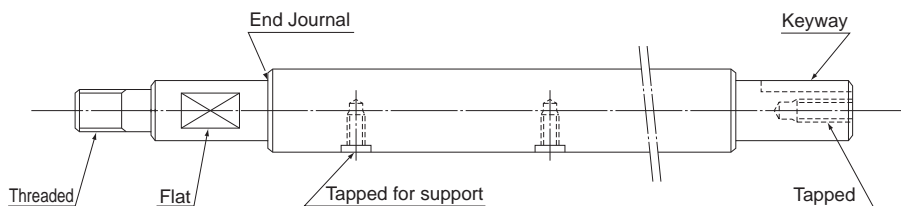

Fig.1

Table of Rows of Balls and Masses for Clearance-adjustable Types and Open Types of the Linear Bushing

Shaft diameter	Clearance-adjustable type			Open type		
	Model No.	Rows of balls	Mass g	Model No.	Rows of balls	Mass g
6	LM 6-AJ	4	7.8	—	—	—
8	LM 8S-AJ	4	10	—	—	—
	LM 8-AJ	4	14.7	—	—	—
10	LM 10-AJ	4	29	—	—	—
12	LM 12-AJ	4	31	—	3	25
13	LM 13-AJ	4	42	LM 13-OP	3	34
16	LM 16-AJ	5(4)	68	LM 16-OP	4(3)	52
20	LM 20-AJ	5	85	LM 20-OP	4	69
25	LM 25-AJ	6(5)	216	LM 25-OP	5(4)	188
30	LM 30-AJ	6	245	LM 30-OP	5	210
35	LM 35-AJ	6	384	LM 35-OP	5	350
38	LM 38-AJ	6	475	LM 38-OP	5	400
40	LM 40-AJ	6	579	LM 40-OP	5	500
50	LM 50-AJ	6	1560	LM 50-OP	5	1340
60	LM 60-AJ	6	1820	LM 60-OP	5	1650
80	LM 80-AJ	6	4320	LM 80-OP	5	3750
100	LM 100-AJ	6	8540	LM 100-OP	5	7200
120	LM 120-AJ	8	14900	LM 120-OP	6	11600

Note) The numbers of ball rows in the table apply to types using a resin retainer. Those of types using a metal retainer are indicated in parentheses.