

Finished Shaft Ends Precision Ball Screw

Model BNK

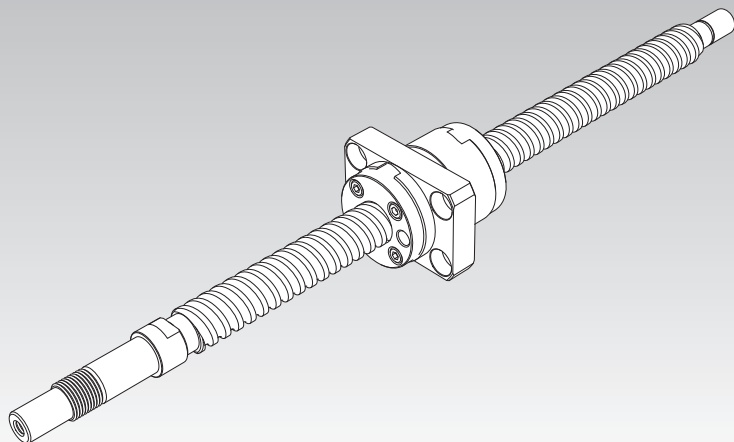

Point of Selection **A15-8**

Options **A15-336**

Model No. **A15-353**

Precautions on Use **A15-358**

Accessories for Lubrication **A24-1**

Mounting Procedure and Maintenance **B15-104**

Lead Angle Accuracy **A15-11**

Accuracy of the Mounting Surface **A15-14**

DN Value **A15-33**

Support Unit **A15-300**

Nut Bracket **A15-330**

Dimensions of Each Model with an Option Attached **A15-344**

Features

To meet the space-saving requirement, this type of Ball Screw has a standardized screw shaft and a ball screw nut. The ends of the screw shaft are standardized to fit the corresponding support unit. The shaft support method with models BNK0401, 0501 and 0601 is “fixed-free,” while other models use the “fixed-supported” method with the shaft directly coupled with the motor.

Screw shafts and nuts are compactly designed. When a support unit and a nut bracket are combined with a Ball Screw, the assembly can be mounted on your machine as it is. Thus, a high-accuracy feed mechanism can easily be achieved.

[Contamination Protection and Lubrication]

Each ball screw nut contains a right amount of grease. In addition, the ball nuts of model BNK0802 or higher contain a labyrinth seal (with models BNK1510, BNK1520, BNK1616, BNK2020 and BNK2520, the end cap also serves as a labyrinth seal).

When foreign material may enter the screw nut, it is necessary to use a dust-prevention device (e.g., bellows) to completely protect the screw shaft.

Types and Features

Model BNK

For this model, screw shafts with a diameter $\phi 4$ to $\phi 25$ mm and a lead 1 to 20 mm are available as the standard.

Specification Table ⇒ **A15-136**

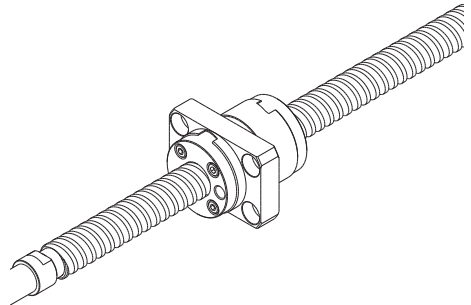

Table of Ball Screw Types with Finished Shaft Ends and the Corresponding Support Units and Nut Brackets

Model No.		BNK																									
		0401		0501		0601		0801		0802		0810		1002		1004		1010									
Accuracy grades		C3, C5, C7		C3, C5, C7		C3, C5, C7		C3, C5, C7		C3, C5, C7		C5, C7		C3, C5, C7		C3, C5, C7		C5, C7									
Axial clearance ^{Note}		G0	GT	G2	G0	GT	G2	G0	GT	G2	G0	GT	G2	—	GT	G2	G0	GT	G2	G0	GT	G2					
Stroke (mm)	20	●			●																						
	30																										
	40	●			●			●			●																
	50																●		●								
	60																										
	70	●			●			●			●																
	100						●		●		●			●		●		●		●							
	120																										
	150								●		●			●		●		●		●							
	170																										
	200													●		●		●		●							
	250													●		●		●		●							
	300													●		●				●							
	350																										
	400																										
	450																										
	500																										
	550																										
	600																										
	700																										
800																											
900																											
1000																											
1100																											
1200																											
1400																											
1600																											
Support unit: square on fixed side		EK4		EK4		EK5		EK6		EK6		EK6		EK8		EK10		EK10									
		—		—		—		—		—		—		—		—		BK10		BK10							
Support unit: round on fixed side		FK4		FK4		FK5		FK6		FK6		FK6		FK8		FK10		FK10									
Support unit: square on supported side		—		—		—		EF6		EF6		EF6		EF8		EF10		EF10									
Support unit: round on supported side		—		—		—		FF6		FF6		FF6		FF6		FF10		FF10									
Nut bracket		—		—		—		—		—		—		—		—		MC1004		MC1004							

Note) Axial clearance: G0: 0 or less

GT: 0.005 mm or less

G2: 0.02 mm or less

For details of the support unit and the nut bracket, see **A15-300** onward and **A15-330** onward, respectively.

BNK0401-3 Shaft diameter: 4; lead: 1

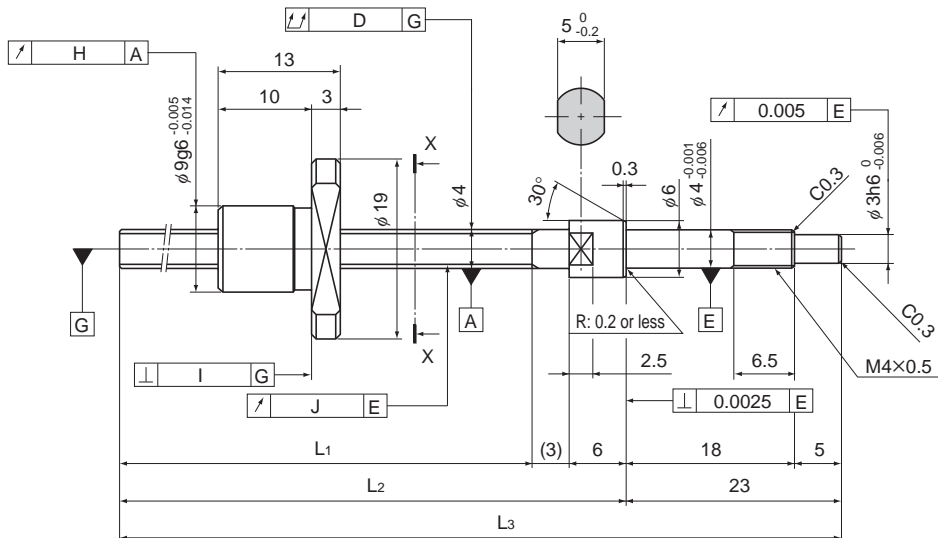

Model No.	Stroke	Screw shaft length		
		L ₁	L ₂	L ₃
BNK 0401-3G0+77LC3Y	20	45	54	77
BNK 0401-3G0+77LC5Y				
BNK 0401-3G2+77LC7Y				
BNK 0401-3G0+97LC3Y	40	65	74	97
BNK 0401-3G0+97LC5Y				
BNK 0401-3G2+97LC7Y				
BNK 0401-3G0+127LC3Y	70	95	104	127
BNK 0401-3G0+127LC5Y				
BNK 0401-3G2+127LC7Y				

Note) A stainless steel type is also available for model BNK0401. When placing an order, add symbol "M" to the end of the model number.

(Example) BNK0401-3G0+77LC3Y M

Symbol for stainless steel type

For accuracy grades C3 and C5, clearance GT is also available as standard.

Finished Shaft Ends Precision Ball Screw

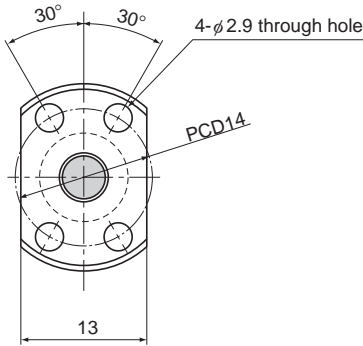

X-X arrow view

Ball Screw Specifications			
Lead (mm)	1		
BCD (mm)	4.15		
Thread minor diameter (mm)	3.4		
Threading direction, No. of threaded grooves	Rightward, 1		
No. of circuits	1 turn × 3 rows		
Clearance symbol	G0	GT	G2
Axial clearance (mm)	0	0.005 or less	0.02 or less
Basic dynamic load rating C_a (kN)	0.29	0.29	0.29
Basic static load rating C_{0a} (kN)	0.42	0.42	0.42
Preload torque (N-m)	to 9.8×10^{-3}	—	—
Spacer ball	None	None	None
Rigidity value (N/ μ m)	35		
Circulation method	Deflector		

Unit: mm

	Runout of the screw shaft axis D	Runout of the nut circumference H	Flange perpendicularity I	Runout of the thread groove surface J	Lead angle accuracy		Nut mass kg	Shaft mass kg/m
					Representative travel distance error	Fluctuation		
	0.015	0.009	0.008	0.008	± 0.008	0.008	0.01	0.07
	0.025	0.012	0.01	0.01	± 0.018	0.018	0.01	0.07
	0.035	0.02	0.014	0.014	Travel distance: $\pm 0.05/300$		0.01	0.07
	0.02	0.009	0.008	0.008	± 0.008	0.008	0.01	0.07
	0.025	0.012	0.01	0.01	± 0.018	0.018	0.01	0.07
	0.035	0.02	0.014	0.014	Travel distance: $\pm 0.05/300$		0.01	0.07
	0.025	0.009	0.008	0.008	± 0.008	0.008	0.01	0.07
	0.035	0.012	0.01	0.01	± 0.018	0.018	0.01	0.07
	0.05	0.02	0.014	0.014	Travel distance: $\pm 0.05/300$		0.01	0.07

BNK0501-3 Shaft diameter: 5; lead: 1

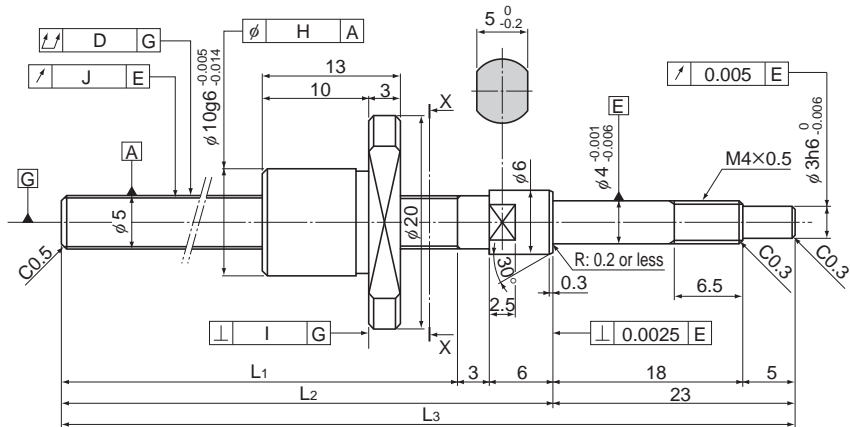

Model No.	Stroke	Screw shaft length		
		L ₁	L ₂	L ₃
BNK 0501-3G0+77LC3Y	20	45	54	77
BNK 0501-3G0+77LC5Y				
BNK 0501-3G2+77LC7Y				
BNK 0501-3G0+97LC3Y	40	65	74	97
BNK 0501-3G0+97LC5Y				
BNK 0501-3G2+97LC7Y				
BNK 0501-3G0+127LC3Y	70	95	104	127
BNK 0501-3G0+127LC5Y				
BNK 0501-3G2+127LC7Y				

Note) A stainless steel type is also available for model BNK0501. When placing an order, add symbol "M" to the end of the model number.

(Example) BNK0501-3G0+77LC3Y M

Symbol for stainless steel type

For accuracy grades C3 and C5, clearance GT is also available as standard.

Finished Shaft Ends Precision Ball Screw

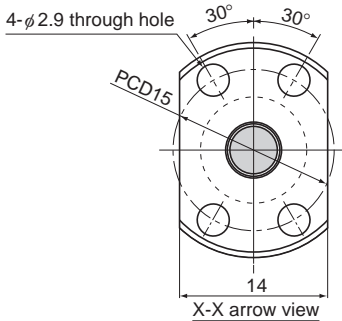

Ball Screw Specifications			
Lead (mm)	1		
BCD (mm)	5.15		
Thread minor diameter (mm)	4.4		
Threading direction, No. of threaded grooves	Rightward, 1		
No. of circuits	1 turn × 3 rows		
Clearance symbol	G0	GT	G2
Axial clearance (mm)	0	0.005 or less	0.02 or less
Basic dynamic load rating C_a (kN)	0.32	0.32	0.32
Basic static load rating C_{0a} (kN)	0.55	0.55	0.55
Preload torque (N-m)	to 9.8×10^{-3}	—	—
Spacer ball	None	None	None
Rigidity value (N/ μ m)	47		
Circulation method	Deflector		

Unit: mm

	Runout of the screw shaft axis D	Runout of the nut circumference H	Flange perpendicularity I	Runout of the thread groove surface J	Lead angle accuracy		Nut mass kg	Shaft mass kg/m
					Representative travel distance error	Fluctuation		
	0.015	0.009	0.008	0.008	± 0.008	0.008	0.012	0.11
	0.025	0.012	0.01	0.01	± 0.018	0.018	0.012	0.11
	0.035	0.02	0.014	0.014	Travel distance: $\pm 0.05/300$		0.012	0.11
	0.02	0.009	0.008	0.008	± 0.008	0.008	0.012	0.11
	0.025	0.012	0.01	0.01	± 0.018	0.018	0.012	0.11
	0.035	0.02	0.014	0.014	Travel distance: $\pm 0.05/300$		0.012	0.11
	0.025	0.009	0.008	0.008	± 0.008	0.008	0.012	0.11
	0.035	0.012	0.01	0.01	± 0.018	0.018	0.012	0.11
	0.05	0.02	0.014	0.014	Travel distance: $\pm 0.05/300$		0.012	0.11

BNK0601-3 Shaft diameter: 6; lead: 1

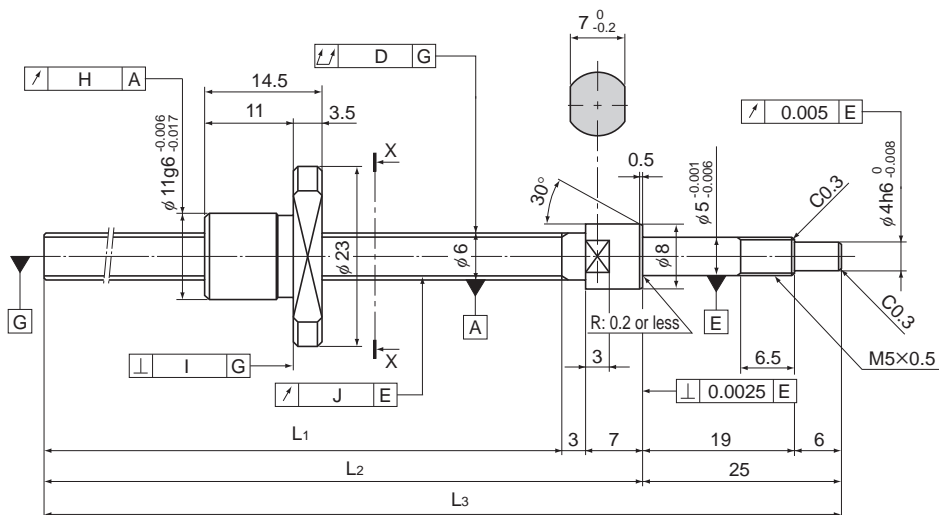

Model No.	Stroke	Screw shaft length		
		L ₁	L ₂	L ₃
BNK 0601-3G0+100LC3Y	40	65	75	100
BNK 0601-3G0+100LC5Y				
BNK 0601-3G2+100LC7Y				
BNK 0601-3G0+130LC3Y	70	95	105	130
BNK 0601-3G0+130LC5Y				
BNK 0601-3G2+130LC7Y				
BNK 0601-3G0+160LC3Y	100	125	135	160
BNK 0601-3G0+160LC5Y				
BNK 0601-3G2+160LC7Y				

Note) A stainless steel type is also available for model BNK0601. When placing an order, add symbol "M" to the end of the model number.

(Example) BNK0601-3G0+100LC3Y M

Symbol for stainless steel type

For accuracy grades C3 and C5, clearance GT is also available as standard.

Finished Shaft Ends Precision Ball Screw

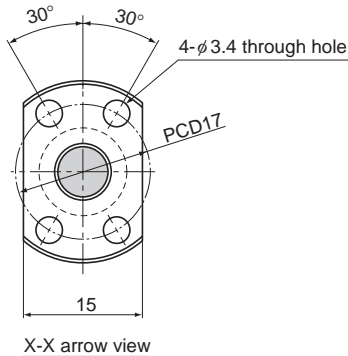

Ball Screw Specifications			
Lead (mm)	1		
BCD (mm)	6.2		
Thread minor diameter (mm)	5.3		
Threading direction, No. of threaded grooves	Rightward, 1		
No. of circuits	1 turn \times 3 rows		
Clearance symbol	G0	GT	G2
Axial clearance (mm)	0	0.005 or less	0.02 or less
Basic dynamic load rating C_a (kN)	0.54	0.54	0.54
Basic static load rating C_{0a} (kN)	0.94	0.94	0.94
Preload torque (N-m)	to 1.3×10^2	—	—
Spacer ball	None	None	None
Rigidity value (N/ μ m)	60		
Circulation method	Deflector		

Unit: mm

	Runout of the screw shaft axis D	Runout of the nut circumference H	Flange perpendicularity I	Runout of the thread groove surface J	Lead angle accuracy		Nut mass kg	Shaft mass kg/m
					Representative travel distance error	Fluctuation		
	0.015	0.009	0.008	0.008	± 0.008	0.008	0.017	0.14
	0.025	0.012	0.01	0.01	± 0.018	0.018	0.017	0.14
	0.035	0.02	0.014	0.014	Travel distance: $\pm 0.05/300$		0.017	0.14
	0.02	0.009	0.008	0.008	± 0.008	0.008	0.017	0.14
	0.035	0.012	0.01	0.01	± 0.018	0.018	0.017	0.14
	0.05	0.02	0.014	0.014	Travel distance: $\pm 0.05/300$		0.017	0.14
	0.025	0.009	0.008	0.008	± 0.01	0.008	0.017	0.14
	0.035	0.012	0.01	0.01	± 0.02	0.018	0.017	0.14
	0.05	0.02	0.014	0.014	Travel distance: $\pm 0.05/300$		0.017	0.14

BNK0801-3 Shaft diameter: 8; lead: 1

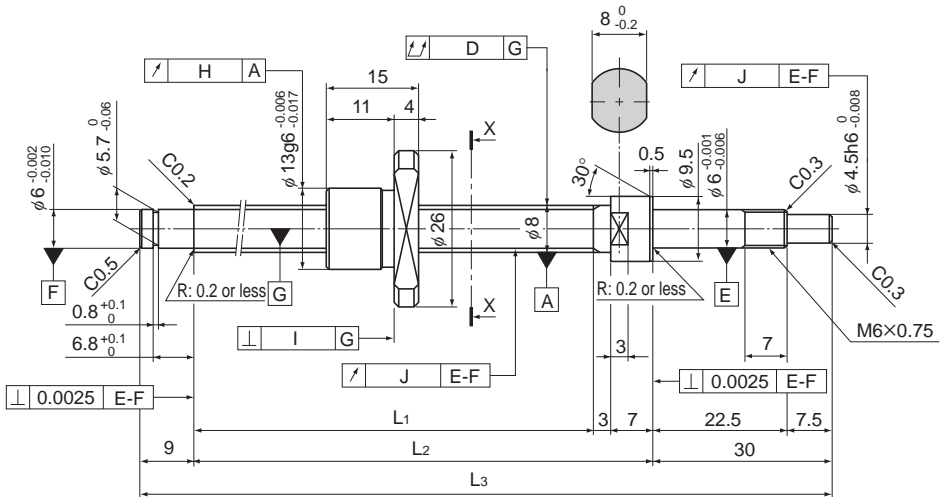

Model No.	Stroke	Screw shaft length		
		L ₁	L ₂	L ₃
BNK 0801-3G0+115LC3Y	40	66	76	115
BNK 0801-3G0+115LC5Y				
BNK 0801-3G2+115LC7Y				
BNK 0801-3G0+145LC3Y	70	96	106	145
BNK 0801-3G0+145LC5Y				
BNK 0801-3G2+145LC7Y				
BNK 0801-3G0+175LC3Y	100	126	136	175
BNK 0801-3G0+175LC5Y				
BNK 0801-3G2+175LC7Y				
BNK 0801-3G0+225LC3Y	150	176	186	225
BNK 0801-3G0+225LC5Y				
BNK 0801-3G2+225LC7Y				

Note) A stainless steel type is also available for model BNK0801. When placing an order, add symbol "M" to the end of the model number.

(Example) BNK0801-3G0+115LC3Y M

Symbol for stainless steel type

For accuracy grades C3 and C5, clearance GT is also available as standard.

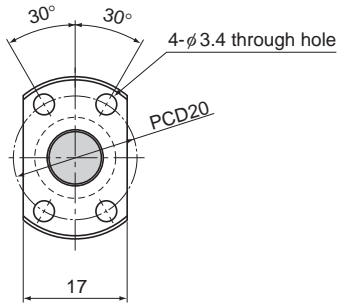

X-X arrow view

Ball Screw Specifications			
Lead (mm)	1		
BCD (mm)	8.2		
Thread minor diameter (mm)	7.3		
Threading direction, No. of threaded grooves	Rightward, 1		
No. of circuits	1 turn × 3 rows		
Clearance symbol	G0	GT	G2
Axial clearance (mm)	0	0.005 or less	0.02 or less
Basic dynamic load rating C_a (kN)	0.64	0.64	0.64
Basic static load rating C_{0a} (kN)	1.4	1.4	1.4
Preload torque (N-m)	to 1.8×10^2	—	—
Spacer ball	None	None	None
Rigidity value (N/ μ m)	80		
Circulation method	Deflector		

Unit: mm

	Runout of the screw shaft axis D	Runout of the nut circumference H	Flange perpendicularity I	Runout of the thread groove surface J	Lead angle accuracy		Nut mass kg	Shaft mass kg/m
					Representative travel distance error	Fluctuation		
	0.025	0.009	0.008	0.008	± 0.008	0.008	0.024	0.29
	0.025	0.012	0.01	0.01	± 0.018	0.018	0.024	0.29
	0.035	0.02	0.014	0.014	Travel distance: $\pm 0.05/300$		0.024	0.29
	0.03	0.009	0.008	0.008	± 0.008	0.008	0.024	0.29
	0.035	0.012	0.01	0.01	± 0.018	0.018	0.024	0.29
	0.05	0.02	0.014	0.014	Travel distance: $\pm 0.05/300$		0.024	0.29
	0.03	0.009	0.008	0.008	± 0.01	0.008	0.024	0.29
	0.035	0.012	0.01	0.01	± 0.02	0.018	0.024	0.29
	0.05	0.02	0.014	0.014	Travel distance: $\pm 0.05/300$		0.024	0.29
	0.035	0.009	0.008	0.008	± 0.01	0.008	0.024	0.29
	0.05	0.012	0.01	0.01	± 0.02	0.018	0.024	0.29
	0.065	0.02	0.014	0.014	Travel distance: $\pm 0.05/300$		0.024	0.29

BNK0802-3 Shaft diameter: 8; lead: 2

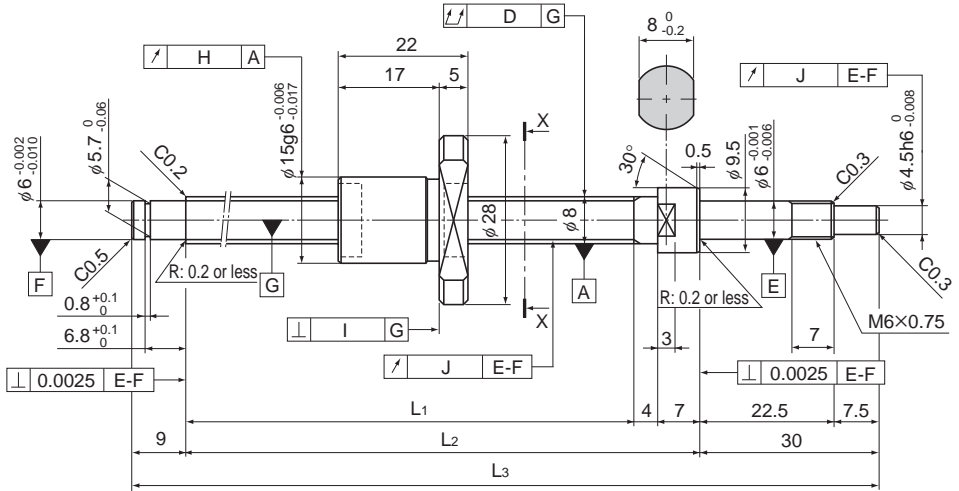

Model No.	Stroke	Screw shaft length		
		L ₁	L ₂	L ₃
BNK 0802-3RRG0+125LC3Y	40	75	86	125
BNK 0802-3RRG0+125LC5Y				
BNK 0802-3RRG2+125LC7Y				
BNK 0802-3RRG0+155LC3Y	70	105	116	155
BNK 0802-3RRG0+155LC5Y				
BNK 0802-3RRG2+155LC7Y				
BNK 0802-3RRG0+185LC3Y	100	135	146	185
BNK 0802-3RRG0+185LC5Y				
BNK 0802-3RRG2+185LC7Y				
BNK 0802-3RRG0+235LC3Y	150	185	196	235
BNK 0802-3RRG0+235LC5Y				
BNK 0802-3RRG2+235LC7Y				

Note) A stainless steel type is also available for model BNK0802. When placing an order, add symbol "M" to the end of the model number.

(Example) BNK0802-3RRG0+125LC3Y M Symbol for stainless steel type

For accuracy grades C3 and C5, clearance GT is also available as standard.

Finished Shaft Ends Precision Ball Screw

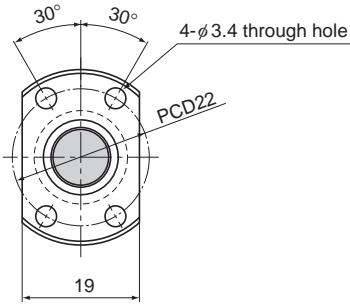

X-X arrow view

Ball Screw Specifications			
Lead (mm)	2		
BCD (mm)	8.3		
Thread minor diameter (mm)	7		
Threading direction, No. of threaded grooves	Rightward, 1		
No. of circuits	1 turn × 3 rows		
Clearance symbol	G0	GT	G2
Axial clearance (mm)	0	0.005 or less	0.02 or less
Basic dynamic load rating C_a (kN)	1.4	1.4	1.4
Basic static load rating C_{0a} (kN)	2.3	2.3	2.3
Preload torque (N-m)	to 2×10^{-2}	—	—
Spacer ball	None	None	None
Rigidity value (N/ μ m)	100		
Circulation method	Deflector		

Unit: mm

	Runout of the screw shaft axis	Runout of the nut circumference	Flange perpendicularity	Runout of the thread groove surface	Lead angle accuracy		Nut mass kg	Shaft mass kg/m
					Representative travel distance error	Fluctuation		
	D	H	I	J				
	0.025	0.009	0.008	0.008	± 0.008	0.008	0.034	0.27
	0.025	0.012	0.01	0.01	± 0.018	0.018	0.034	0.27
	0.035	0.02	0.014	0.014	Travel distance: $\pm 0.05/300$		0.034	0.27
	0.03	0.009	0.008	0.008	± 0.01	0.008	0.034	0.27
	0.035	0.012	0.01	0.01	± 0.02	0.018	0.034	0.27
	0.05	0.02	0.014	0.014	Travel distance: $\pm 0.05/300$		0.034	0.27
	0.03	0.009	0.008	0.008	± 0.01	0.008	0.034	0.27
	0.035	0.012	0.01	0.01	± 0.02	0.018	0.034	0.27
	0.05	0.02	0.014	0.014	Travel distance: $\pm 0.05/300$		0.034	0.27
	0.035	0.009	0.008	0.008	± 0.01	0.008	0.034	0.27
	0.05	0.012	0.01	0.01	± 0.02	0.018	0.034	0.27
	0.065	0.02	0.014	0.014	Travel distance: $\pm 0.05/300$		0.034	0.27

BNK0810-3 Shaft diameter: 8; lead: 10

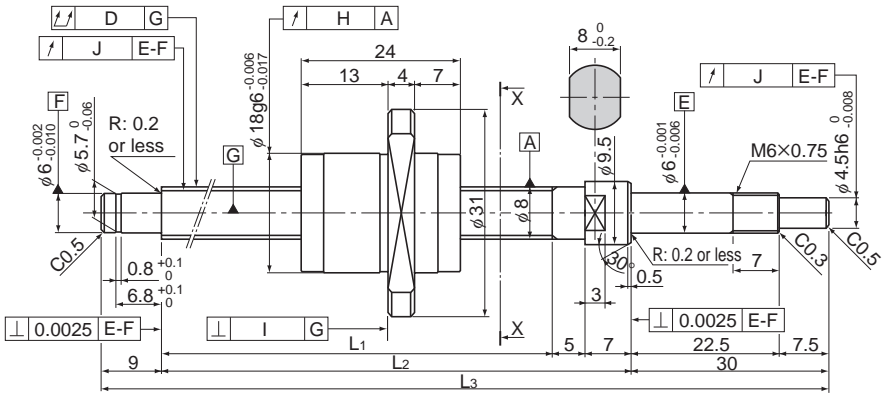

Model No.	Stroke	Screw shaft length		
		L ₁	L ₂	L ₃
BNK 0810-3GT+205LC5Y	100	154	166	205
BNK 0810-3G2+205LC7Y				
BNK 0810-3GT+255LC5Y	150	204	216	255
BNK 0810-3G2+255LC7Y				
BNK 0810-3GT+305LC5Y	200	254	266	305
BNK 0810-3G2+305LC7Y				
BNK 0810-3GT+355LC5Y	250	304	316	355
BNK 0810-3G2+355LC7Y				
BNK 0810-3GT+405LC5Y	300	354	366	405
BNK 0810-3G2+405LC7Y				

Finished Shaft Ends Precision Ball Screw

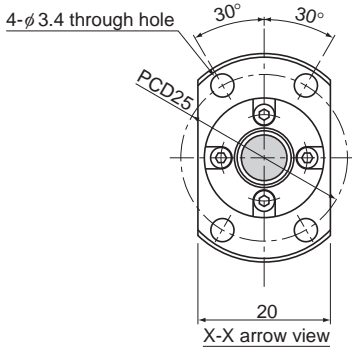

Ball Screw Specifications		
Lead (mm)	10	
BCD (mm)	8.4	
Thread minor diameter (mm)	6.7	
Threading direction, No. of threaded grooves	Rightward, 2	
No. of circuits	1.5 turns \times 2 rows	
Clearance symbol	GT	G2
Axial clearance (mm)	0.005 or less	0.02 or less
Basic dynamic load rating C_a (kN)	2.16	2.16
Basic static load rating C_{0a} (kN)	3.82	3.82
Preload torque (N-m)	—	—
Spacer ball	None	None
Rigidity value (N/ μ m)	100	
Circulation method	End cap	

Unit: mm

	Runout of the screw shaft axis D	Runout of the nut circumference H	Flange perpendicularity I	Runout of the thread groove surface J	Lead angle accuracy		Nut mass kg	Shaft mass kg/m
					Representative travel distance error	Fluctuation		
	0.05	0.012	0.01	0.01	± 0.02	0.018	0.049	0.30
	0.065	0.02	0.014	0.014	Travel distance: $\pm 0.05/300$		0.049	0.30
	0.05	0.012	0.01	0.01	± 0.023	0.018	0.049	0.30
	0.065	0.02	0.014	0.014	Travel distance: $\pm 0.05/300$		0.049	0.30
	0.05	0.012	0.01	0.01	± 0.023	0.018	0.049	0.30
	0.065	0.02	0.014	0.014	Travel distance: $\pm 0.05/300$		0.049	0.30
	0.06	0.012	0.01	0.01	± 0.023	0.018	0.049	0.30
	0.075	0.02	0.014	0.014	Travel distance: $\pm 0.05/300$		0.049	0.30
	0.07	0.012	0.01	0.01	± 0.025	0.018	0.049	0.30
	0.09	0.02	0.014	0.014	Travel distance: $\pm 0.05/300$		0.049	0.30

Ball Screw

BNK1002-3 Shaft diameter: 10; lead: 2

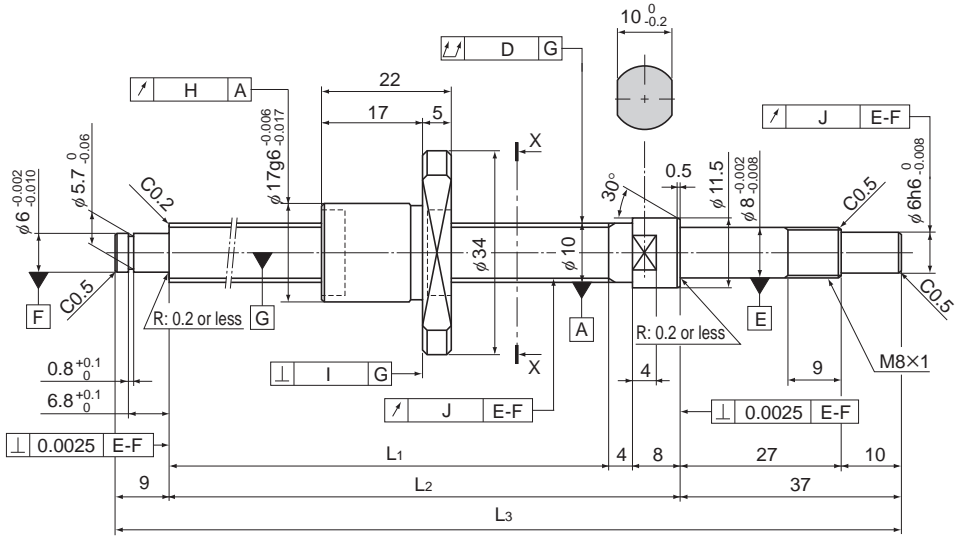

Model No.	Stroke	Screw shaft length		
		L ₁	L ₂	L ₃
BNK 1002-3RRG0+143LC3Y	50	85	97	143
BNK 1002-3RRG0+143LC5Y				
BNK 1002-3RRG2+143LC7Y				
BNK 1002-3RRG0+193LC3Y	100	135	147	193
BNK 1002-3RRG0+193LC5Y				
BNK 1002-3RRG2+193LC7Y				
BNK 1002-3RRG0+243LC3Y	150	185	197	243
BNK 1002-3RRG0+243LC5Y				
BNK 1002-3RRG2+243LC7Y				
BNK 1002-3RRG0+293LC3Y	200	235	247	293
BNK 1002-3RRG0+293LC5Y				
BNK 1002-3RRG2+293LC7Y				

Note) A stainless steel type is also available for model BNK1002. When placing an order, add symbol "M" to the end of the model number.

(Example) BNK1002-3RRG0+143LC3Y M

Symbol for stainless steel type

For accuracy grades C3 and C5, clearance GT is also available as standard.

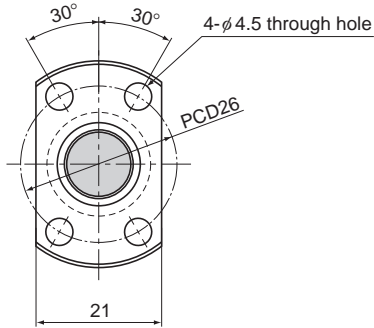

X-X arrow view

Ball Screw Specifications			
Lead (mm)	2		
BCD (mm)	10.3		
Thread minor diameter (mm)	9		
Threading direction, No. of threaded grooves	Rightward, 1		
No. of circuits	1 turn × 3 rows		
Clearance symbol	G0	GT	G2
Axial clearance (mm)	0	0.005 or less	0.02 or less
Basic dynamic load rating C_a (kN)	1.5	1.5	1.5
Basic static load rating C_{0a} (kN)	2.9	2.9	2.9
Preload torque (N-m)	to 2.5×10^2	—	—
Spacer ball	None	None	None
Rigidity value (N/ μ m)	100		
Circulation method	Deflector		

Unit: mm

	Runout of the screw shaft axis D	Runout of the nut circumference H	Flange perpendicularity I	Runout of the thread groove surface J	Lead angle accuracy		Nut mass kg	Shaft mass kg/m
					Representative travel distance error	Fluctuation		
	0.02	0.009	0.008	0.007	± 0.008	0.008	0.045	0.47
	0.035	0.012	0.01	0.011	± 0.018	0.018	0.045	0.47
	0.04	0.02	0.014	0.014	Travel distance: $\pm 0.05/300$		0.045	0.47
	0.03	0.009	0.008	0.007	± 0.01	0.008	0.045	0.47
	0.035	0.012	0.01	0.011	± 0.02	0.018	0.045	0.47
	0.04	0.02	0.014	0.014	Travel distance: $\pm 0.05/300$		0.045	0.47
	0.03	0.009	0.008	0.007	± 0.01	0.008	0.045	0.47
	0.04	0.012	0.01	0.011	± 0.02	0.018	0.045	0.47
	0.055	0.02	0.014	0.014	Travel distance: $\pm 0.05/300$		0.045	0.47
	0.03	0.009	0.008	0.007	± 0.012	0.008	0.045	0.47
	0.04	0.012	0.01	0.011	± 0.023	0.018	0.045	0.47
	0.055	0.02	0.014	0.014	Travel distance: $\pm 0.05/300$		0.045	0.47

BNK1004-2.5 Shaft diameter: 10; lead: 4

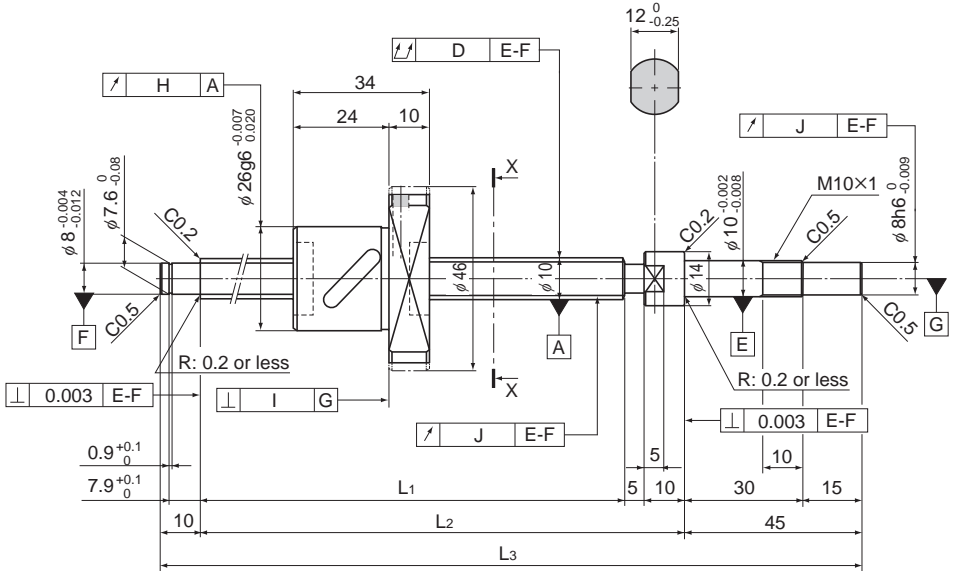

Model No.	Stroke	Screw shaft length		
		L ₁	L ₂	L ₃
BNK 1004-2.5RRG0+180LC3Y	50	110	125	180
BNK 1004-2.5RRG0+180LC5Y				
BNK 1004-2.5RRG2+180LC7Y				
BNK 1004-2.5RRG0+230LC3Y	100	160	175	230
BNK 1004-2.5RRG0+230LC5Y				
BNK 1004-2.5RRG2+230LC7Y				
BNK 1004-2.5RRG0+280LC3Y	150	210	225	280
BNK 1004-2.5RRG0+280LC5Y				
BNK 1004-2.5RRG2+280LC7Y				
BNK 1004-2.5RRG0+330LC3Y	200	260	275	330
BNK 1004-2.5RRG0+330LC5Y				
BNK 1004-2.5RRG2+330LC7Y				
BNK 1004-2.5RRG0+380LC3Y	250	310	325	380
BNK 1004-2.5RRG0+380LC5Y				
BNK 1004-2.5RRG2+380LC7Y				

Note) For accuracy grades C3 and C5, clearance GT is also available as standard.

Finished Shaft Ends Precision Ball Screw

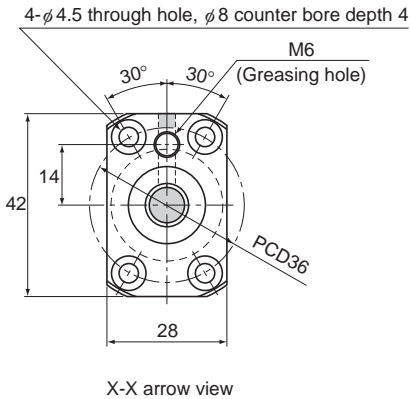

Ball Screw Specifications			
Lead (mm)	4		
BCD (mm)	10.5		
Thread minor diameter (mm)	7.8		
Threading direction, No. of threaded grooves	Rightward, 1		
No. of circuits	2.5 turns \times 1 row		
Clearance symbol	G0	GT	G2
Axial clearance (mm)	0	0.005 or less	0.02 or less
Basic dynamic load rating C_a (kN)	2.1	3.4	3.4
Basic static load rating C_{0a} (kN)	2.7	5.4	5.4
Preload torque (N-m)	9.8×10^{-3} to 4.9×10^{-2}	—	—
Spacer ball	1 : 1	None	None
Rigidity value (N/ μ m)	50	100	
Circulation method	Return pipe		

Unit: mm

	Runout of the screw shaft axis	Runout of the nut circumference	Flange perpendicularity	Runout of the thread groove surface	Lead angle accuracy		Nut mass kg	Shaft mass kg/m
					Representative travel distance error	Fluctuation		
	D	H	I	J				
	0.02	0.009	0.008	0.008	± 0.01	0.008	0.15	0.32
	0.035	0.012	0.01	0.011	± 0.02	0.018	0.15	0.32
	0.04	0.02	0.014	0.014	Travel distance: $\pm 0.05/300$		0.15	0.32
	0.03	0.009	0.008	0.008	± 0.01	0.008	0.15	0.32
	0.04	0.012	0.01	0.011	± 0.02	0.018	0.15	0.32
	0.055	0.02	0.014	0.014	Travel distance: $\pm 0.05/300$		0.15	0.32
	0.03	0.009	0.008	0.008	± 0.012	0.008	0.15	0.32
	0.04	0.012	0.01	0.011	± 0.023	0.018	0.15	0.32
	0.055	0.02	0.014	0.014	Travel distance: $\pm 0.05/300$		0.15	0.32
	0.04	0.009	0.008	0.008	± 0.012	0.008	0.15	0.32
	0.05	0.012	0.01	0.011	± 0.023	0.018	0.15	0.32
	0.065	0.02	0.014	0.014	Travel distance: $\pm 0.05/300$		0.15	0.32
	0.04	0.009	0.008	0.008	± 0.012	0.008	0.15	0.32
	0.05	0.012	0.01	0.011	± 0.023	0.018	0.15	0.32
	0.065	0.02	0.014	0.014	Travel distance: $\pm 0.05/300$		0.15	0.32

BNK1010-1.5 Shaft diameter: 10; lead: 10

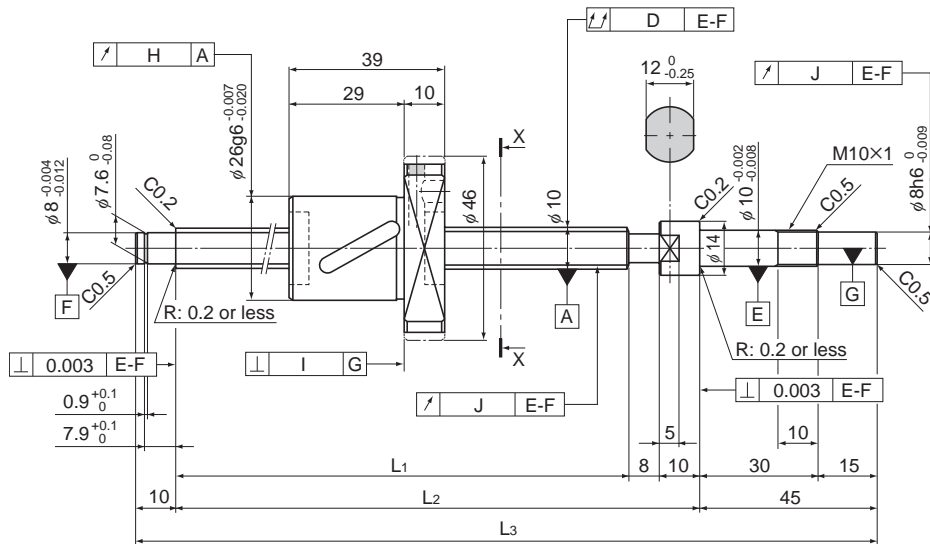

Model No.	Stroke	Screw shaft length		
		L ₁	L ₂	L ₃
BNK 1010-1.5RRG0+240LC5Y	100	167	185	240
BNK 1010-1.5RRG2+240LC7Y				
BNK 1010-1.5RRG0+290LC5Y	150	217	235	290
BNK 1010-1.5RRG2+290LC7Y				
BNK 1010-1.5RRG0+340LC5Y	200	267	285	340
BNK 1010-1.5RRG2+340LC7Y				
BNK 1010-1.5RRG0+390LC5Y	250	317	335	390
BNK 1010-1.5RRG2+390LC7Y				
BNK 1010-1.5RRG0+440LC5Y	300	367	385	440
BNK 1010-1.5RRG2+440LC7Y				

Note) For accuracy grade C5, clearance GT is also standardized.

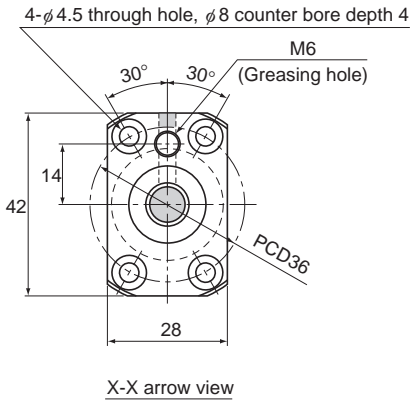

Ball Screw Specifications			
Lead (mm)	10		
BCD (mm)	10.5		
Thread minor diameter (mm)	7.8		
Threading direction, No. of threaded grooves	Rightward, 1		
No. of circuits	1.5 turns \times 1 row		
Clearance symbol	G0	GT	G2
Axial clearance (mm)	0	0.005 or less	0.02 or less
Basic dynamic load rating C_a (kN)	1.3	2.1	2.1
Basic static load rating C_{0a} (kN)	1.6	3.1	3.1
Preload torque (N-m)	9.8×10^3 to 4.9×10^2	—	—
Spacer ball	1 : 1	None	None
Rigidity value (N/ μ m)	70	140	
Circulation method	Return pipe		

Unit: mm

	Runout of the screw shaft axis D	Runout of the nut circumference H	Flange perpendicularity I	Runout of the thread groove surface J	Lead angle accuracy		Nut mass kg	Shaft mass kg/m
					Representative travel distance error	Fluctuation		
	0.04	0.012	0.01	0.011	± 0.02	0.018	0.17	0.5
	0.055	0.02	0.014	0.014	Travel distance: $\pm 0.05/300$		0.17	0.5
	0.04	0.012	0.01	0.011	± 0.023	0.018	0.17	0.5
	0.055	0.02	0.014	0.014	Travel distance: $\pm 0.05/300$		0.17	0.5
	0.05	0.012	0.01	0.011	± 0.023	0.018	0.17	0.5
	0.065	0.02	0.014	0.014	Travel distance: $\pm 0.05/300$		0.17	0.5
	0.05	0.012	0.01	0.011	± 0.025	0.02	0.17	0.5
	0.065	0.02	0.014	0.014	Travel distance: $\pm 0.05/300$		0.17	0.5
	0.065	0.012	0.01	0.011	± 0.025	0.02	0.17	0.5
	0.08	0.02	0.014	0.014	Travel distance: $\pm 0.05/300$		0.17	0.5

BNK1202-3 Shaft diameter: 12; lead: 2

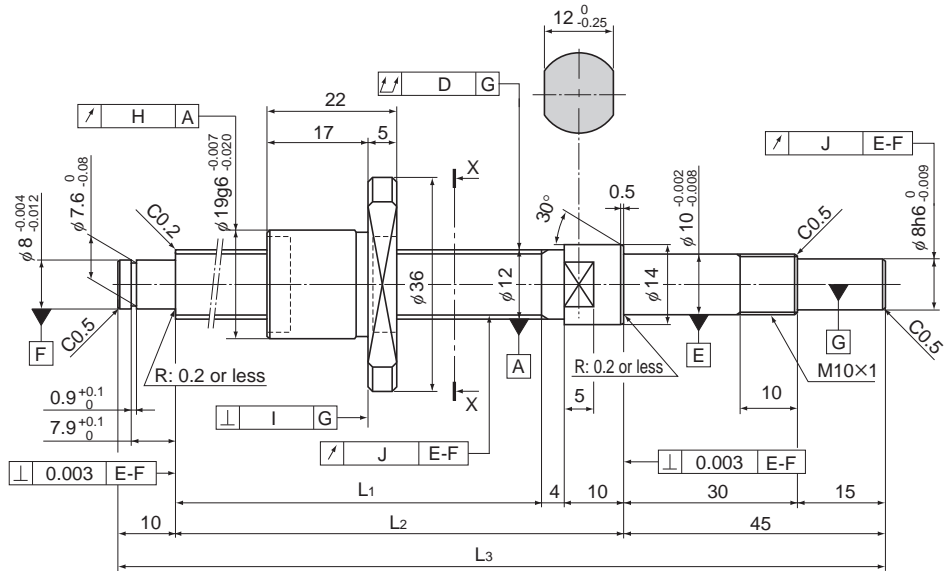

Model No.	Stroke	Screw shaft length		
		L ₁	L ₂	L ₃
BNK 1202-3RRG0+154LC3Y	50	85	99	154
BNK 1202-3RRG0+154LC5Y				
BNK 1202-3RRG2+154LC7Y				
BNK 1202-3RRG0+204LC3Y	100	135	149	204
BNK 1202-3RRG0+204LC5Y				
BNK 1202-3RRG2+204LC7Y				
BNK 1202-3RRG0+254LC3Y	150	185	199	254
BNK 1202-3RRG0+254LC5Y				
BNK 1202-3RRG2+254LC7Y				
BNK 1202-3RRG0+304LC3Y	200	235	249	304
BNK 1202-3RRG0+304LC5Y				
BNK 1202-3RRG2+304LC7Y				
BNK 1202-3RRG0+354LC3Y	250	285	299	354
BNK 1202-3RRG0+354LC5Y				
BNK 1202-3RRG2+354LC7Y				

Note) A stainless steel type is also available for model BNK1202. When placing an order, add symbol "M" to the end of the model number.

(Example) BNK1202-3RRG0+154LC3Y M

Symbol for stainless steel type

For accuracy grades C3 and C5, clearance GT is also available as standard.

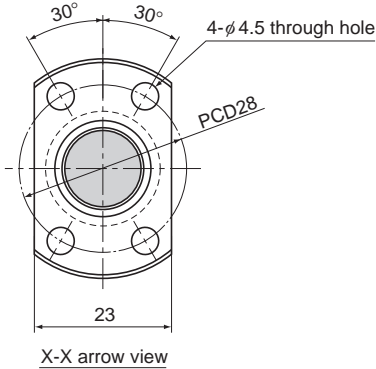

Ball Screw Specifications			
Lead (mm)	2		
BCD (mm)	12.3		
Thread minor diameter (mm)	11		
Threading direction, No. of threaded grooves	Rightward, 1		
No. of circuits	1 turn × 3 rows		
Clearance symbol	G0	GT	G2
Axial clearance (mm)	0	0.005 or less	0.02 or less
Basic dynamic load rating C_a (kN)	1.7	1.7	1.7
Basic static load rating C_{0a} (kN)	3.6	3.6	3.6
Preload torque (N-m)	4.0×10^3 to 3.4×10^2	—	—
Spacer ball	None	None	None
Rigidity value (N/μm)	120		
Circulation method	Deflector		

Unit: mm

	Runout of the screw shaft axis	Runout of the nut circumference	Flange perpendicularity	Runout of the thread groove surface	Lead angle accuracy		Nut mass kg	Shaft mass kg/m
					Representative travel distance error	Fluctuation		
	D	H	I	J				
	0.02	0.01	0.008	0.007	±0.008	0.008	0.05	0.71
	0.035	0.012	0.01	0.011	±0.018	0.018	0.05	0.71
	0.04	0.02	0.014	0.014	Travel distance: ±0.05/300		0.05	0.71
	0.03	0.01	0.008	0.007	±0.01	0.008	0.05	0.71
	0.04	0.012	0.01	0.011	±0.02	0.018	0.05	0.71
	0.055	0.02	0.014	0.014	Travel distance: ±0.05/300		0.05	0.71
	0.03	0.01	0.008	0.007	±0.01	0.008	0.05	0.71
	0.04	0.012	0.01	0.011	±0.02	0.018	0.05	0.71
	0.055	0.02	0.014	0.014	Travel distance: ±0.05/300		0.05	0.71
	0.04	0.01	0.008	0.007	±0.012	0.008	0.05	0.71
	0.05	0.012	0.01	0.011	±0.023	0.018	0.05	0.71
	0.055	0.02	0.014	0.014	Travel distance: ±0.05/300		0.05	0.71
	0.04	0.01	0.008	0.007	±0.012	0.008	0.05	0.71
	0.05	0.012	0.01	0.011	±0.023	0.018	0.05	0.71
	0.065	0.02	0.014	0.014	Travel distance: ±0.05/300		0.05	0.71

BNK1205-2.5 Shaft diameter: 12; lead: 5

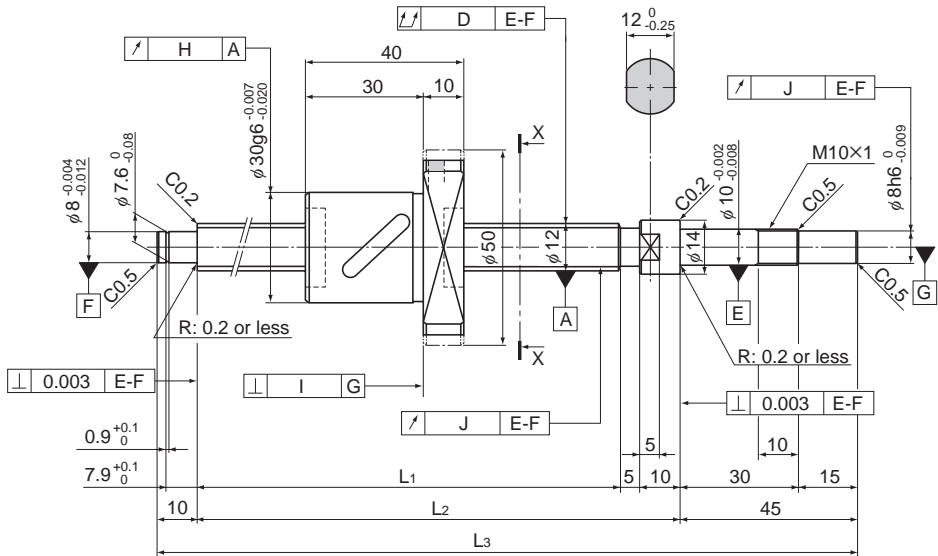

Model No.	Stroke	Screw shaft length		
		L ₁	L ₂	L ₃
BNK 1205-2.5RRG0+180LC3Y	50	110	125	180
BNK 1205-2.5RRG0+180LC5Y				
BNK 1205-2.5RRG2+180LC7Y				
BNK 1205-2.5RRG0+230LC3Y	100	160	175	230
BNK 1205-2.5RRG0+230LC5Y				
BNK 1205-2.5RRG2+230LC7Y				
BNK 1205-2.5RRG0+280LC3Y	150	210	225	280
BNK 1205-2.5RRG0+280LC5Y				
BNK 1205-2.5RRG2+280LC7Y				
BNK 1205-2.5RRG0+330LC3Y	200	260	275	330
BNK 1205-2.5RRG0+330LC5Y				
BNK 1205-2.5RRG2+330LC7Y				
BNK 1205-2.5RRG0+380LC3Y	250	310	325	380
BNK 1205-2.5RRG0+380LC5Y				
BNK 1205-2.5RRG2+380LC7Y				

Note) For accuracy grades C3 and C5, clearance GT is also available as standard.

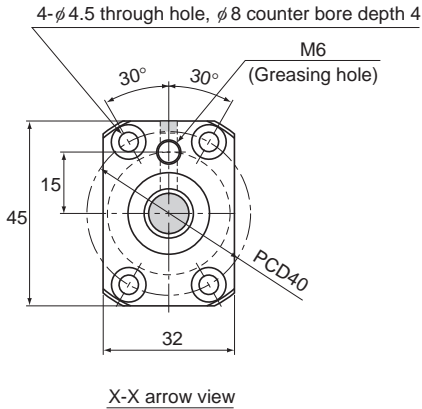

Ball Screw Specifications			
Lead (mm)	5		
BCD (mm)	12.3		
Thread minor diameter (mm)	9.6		
Threading direction, No. of threaded grooves	Rightward, 1		
No. of circuits	2.5 turns \times 1 row		
Clearance symbol	G0	GT	G2
Axial clearance (mm)	0	0.005 or less	0.02 or less
Basic dynamic load rating C_a (kN)	2.3	3.7	3.7
Basic static load rating C_{0a} (kN)	3.2	6.4	6.4
Preload torque (N-m)	9.8×10^3 to 4.9×10^2	—	—
Spacer ball	1 : 1	None	None
Rigidity value (N/ μ m)	60	120	
Circulation method	Return pipe		

Unit: mm

	Runout of the screw shaft axis	Runout of the nut circumference	Flange perpendicularity	Runout of the thread groove surface	Lead angle accuracy		Nut mass kg	Shaft mass kg/m
					Representative travel distance error	Fluctuation		
	D	H	I	J				
	0.02	0.009	0.008	0.008	± 0.01	0.008	0.22	0.61
	0.035	0.012	0.01	0.011	± 0.02	0.018	0.22	0.61
	0.04	0.02	0.014	0.014	Travel distance: $\pm 0.05/300$		0.22	0.61
	0.03	0.009	0.008	0.008	± 0.01	0.008	0.22	0.61
	0.04	0.012	0.01	0.011	± 0.02	0.018	0.22	0.61
	0.055	0.02	0.014	0.014	Travel distance: $\pm 0.05/300$		0.22	0.61
	0.03	0.009	0.008	0.008	± 0.012	0.008	0.22	0.61
	0.04	0.012	0.01	0.011	± 0.023	0.018	0.22	0.61
	0.055	0.02	0.014	0.014	Travel distance: $\pm 0.05/300$		0.22	0.61
	0.04	0.009	0.008	0.008	± 0.012	0.008	0.22	0.61
	0.05	0.012	0.01	0.011	± 0.023	0.018	0.22	0.61
	0.065	0.02	0.014	0.014	Travel distance: $\pm 0.05/300$		0.22	0.61
	0.04	0.009	0.008	0.008	± 0.012	0.008	0.22	0.61
	0.05	0.012	0.01	0.011	± 0.023	0.018	0.22	0.61
	0.065	0.02	0.014	0.014	Travel distance: $\pm 0.05/300$		0.22	0.61

BNK1208-2.6 Shaft diameter: 12; lead: 8

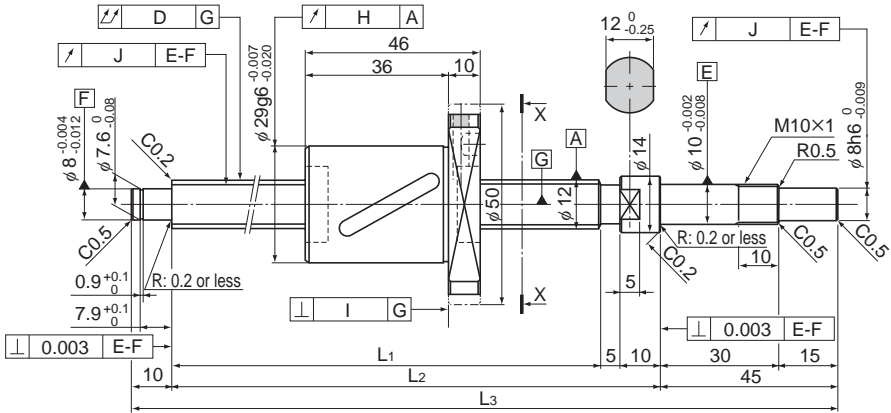

Model No.	Stroke	Screw shaft length		
		L ₁	L ₂	L ₃
BNK 1208-2.6RRG2+180LC7Y	50	110	125	180
BNK 1208-2.6RRG2+230LC7Y	100	160	175	230
BNK 1208-2.6RRG2+280LC7Y	150	210	225	280
BNK 1208-2.6RRG2+330LC7Y	200	260	275	330
BNK 1208-2.6RRG2+380LC7Y	250	310	325	380

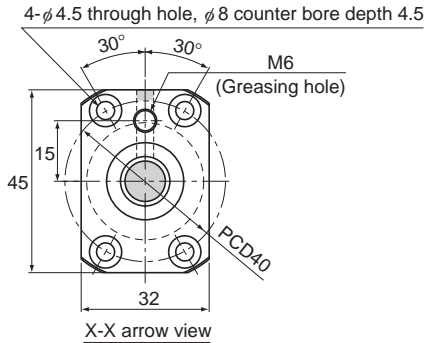

Ball Screw Specifications	
Lead (mm)	8
BCD (mm)	12.65
Thread minor diameter (mm)	9.7
Threading direction, No. of threaded grooves	Rightward, 1
No. of circuits	2.6 turns \times 1 row
Clearance symbol	G2
Axial clearance (mm)	0.02 or less
Basic dynamic load rating C_a (kN)	4.7
Basic static load rating C_{0a} (kN)	7.5
Preload torque (N-m)	—
Spacer ball	None
Rigidity value (N/ μ m)	127
Circulation method	Return pipe

Unit: mm

	Runout of the screw shaft axis	Runout of the nut circumference	Flange perpendicularity	Runout of the thread groove surface	Lead angle accuracy	Nut mass kg	Shaft mass kg/m
	D	H	I	J			
	0.04	0.02	0.014	0.014	Travel distance: $\pm 0.05/300$	0.269	0.64
	0.055	0.02	0.014	0.014	Travel distance: $\pm 0.05/300$	0.269	0.64
	0.055	0.02	0.014	0.014	Travel distance: $\pm 0.05/300$	0.269	0.64
	0.065	0.02	0.014	0.014	Travel distance: $\pm 0.05/300$	0.269	0.64
	0.065	0.02	0.014	0.014	Travel distance: $\pm 0.05/300$	0.269	0.64

BNK1402-3 Shaft diameter: 14; lead: 2

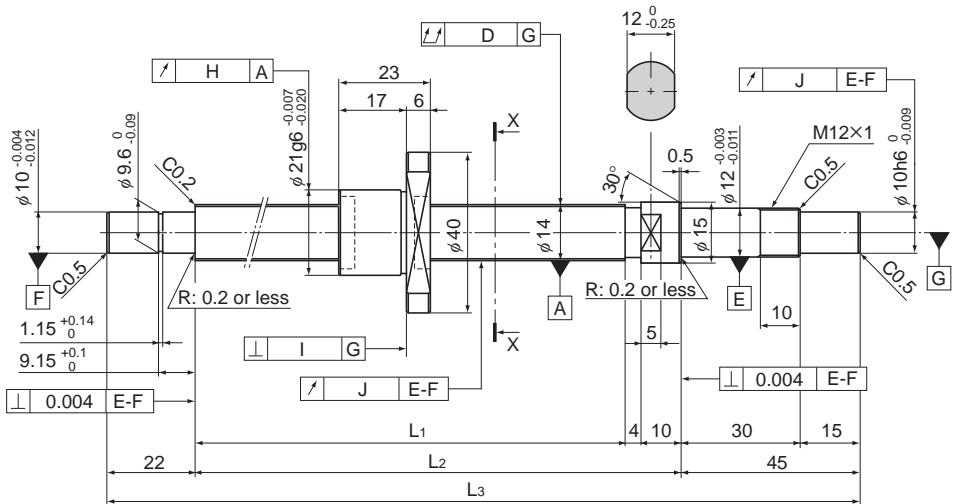

Model No.	Stroke	Screw shaft length		
		L ₁	L ₂	L ₃
BNK 1402-3RRG0+166LC3Y	50	85	99	166
BNK 1402-3RRG0+166LC5Y				
BNK 1402-3RRG2+166LC7Y				
BNK 1402-3RRG0+216LC3Y	100	135	149	216
BNK 1402-3RRG0+216LC5Y				
BNK 1402-3RRG2+216LC7Y				
BNK 1402-3RRG0+266LC3Y	150	185	199	266
BNK 1402-3RRG0+266LC5Y				
BNK 1402-3RRG2+266LC7Y				
BNK 1402-3RRG0+316LC3Y	200	235	249	316
BNK 1402-3RRG0+316LC5Y				
BNK 1402-3RRG2+316LC7Y				
BNK 1402-3RRG0+416LC3Y	300	335	349	416
BNK 1402-3RRG0+416LC5Y				
BNK 1402-3RRG2+416LC7Y				

Note) A stainless steel type is also available for model BNK1402. When placing an order, add symbol "M" to the end of the model number.

(Example) BNK1402-3RRG0+166LC3Y M

Symbol for stainless steel type

For accuracy grades C3 and C5, clearance GT is also available as standard.

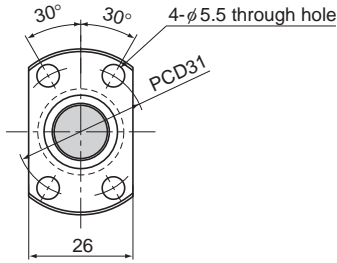

X-X arrow view

Ball Screw Specifications			
Lead (mm)	2		
BCD (mm)	14.3		
Thread minor diameter (mm)	13		
Threading direction, No. of threaded grooves	Rightward, 1		
No. of circuits	1 turn × 3 rows		
Clearance symbol	G0	GT	G2
Axial clearance (mm)	0	0.005 or less	0.02 or less
Basic dynamic load rating C_a (kN)	1.8	1.8	1.8
Basic static load rating C_{0a} (kN)	4.3	4.3	4.3
Preload torque (N-m)	4.9×10^3 to 4.9×10^2	—	—
Spacer ball	None	None	None
Rigidity value (N/μm)	140		
Circulation method	Deflector		

Unit: mm

	Runout of the screw shaft axis	Runout of the nut circumference	Flange perpendicularity	Runout of the thread groove surface	Lead angle accuracy		Nut mass kg	Shaft mass kg/m
					Representative travel distance error	Fluctuation		
	D	H	I	J				
	0.02	0.01	0.008	0.009	±0.008	0.008	0.15	1.0
	0.025	0.012	0.01	0.012	±0.018	0.018	0.15	1.0
	0.04	0.02	0.014	0.014	Travel distance: ±0.05/300		0.15	1.0
	0.025	0.01	0.008	0.009	±0.01	0.008	0.15	1.0
	0.03	0.012	0.01	0.012	±0.02	0.018	0.15	1.0
	0.045	0.02	0.014	0.014	Travel distance: ±0.05/300		0.15	1.0
	0.025	0.01	0.008	0.009	±0.01	0.008	0.15	1.0
	0.03	0.012	0.01	0.012	±0.02	0.018	0.15	1.0
	0.045	0.02	0.014	0.014	Travel distance: ±0.05/300		0.15	1.0
	0.03	0.01	0.008	0.009	±0.012	0.008	0.15	1.0
	0.04	0.012	0.01	0.012	±0.023	0.018	0.15	1.0
	0.055	0.02	0.014	0.014	Travel distance: ±0.05/300		0.15	1.0
	0.04	0.01	0.008	0.009	±0.013	0.01	0.15	1.0
	0.05	0.012	0.01	0.012	±0.025	0.02	0.15	1.0
	0.06	0.02	0.014	0.014	Travel distance: ±0.05/300		0.15	1.0

BNK1404-3 Shaft diameter: 14; lead: 4

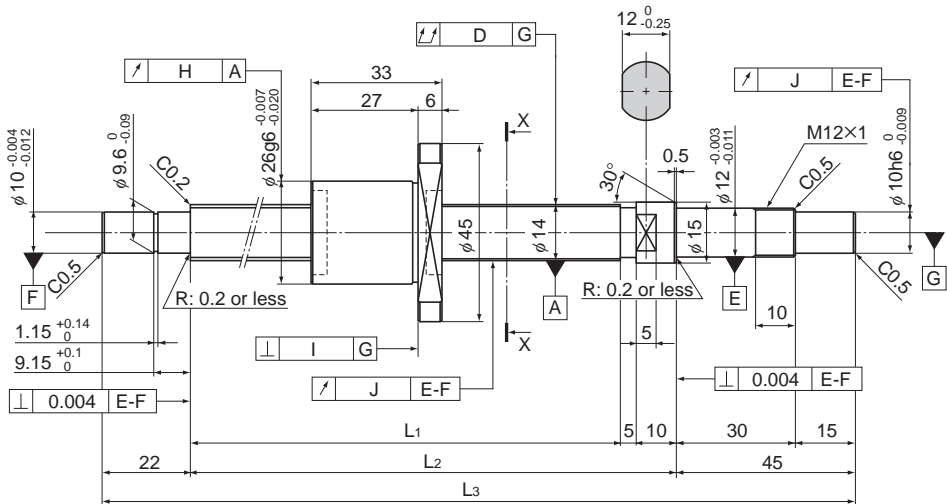

Model No.	Stroke	Screw shaft length		
		L ₁	L ₂	L ₃
BNK 1404-3RRG0+230LC3Y	100	148	163	230
BNK 1404-3RRG0+230LC5Y				
BNK 1404-3RRG2+230LC7Y				
BNK 1404-3RRG0+280LC3Y	150	198	213	280
BNK 1404-3RRG0+280LC5Y				
BNK 1404-3RRG2+280LC7Y				
BNK 1404-3RRG0+330LC3Y	200	248	263	330
BNK 1404-3RRG0+330LC5Y				
BNK 1404-3RRG2+330LC7Y				
BNK 1404-3RRG0+430LC3Y	300	348	363	430
BNK 1404-3RRG0+430LC5Y				
BNK 1404-3RRG2+430LC7Y				
BNK 1404-3RRG0+530LC3Y	400	448	463	530
BNK 1404-3RRG0+530LC5Y				
BNK 1404-3RRG2+530LC7Y				

Note) A stainless steel type is also available for model BNK1404. When placing an order, add symbol "M" to the end of the model number.

(Example) BNK1404-3RRG0+230LC3Y M

_____ Symbol for stainless steel type

For accuracy grades C3 and C5, clearance GT is also available as standard.

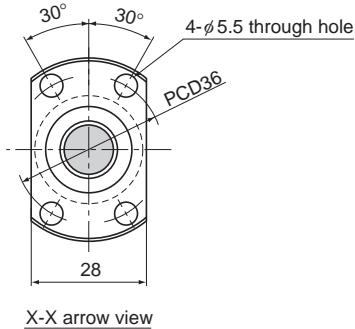

Ball Screw Specifications			
Lead (mm)	4		
BCD (mm)	14.65		
Thread minor diameter (mm)	12.2		
Threading direction, No. of threaded grooves	Rightward, 1		
No. of circuits	1 turn \times 3 rows		
Clearance symbol	G0	GT	G2
Axial clearance (mm)	0	0.005 or less	0.02 or less
Basic dynamic load rating C_a (kN)	4.2	4.2	4.2
Basic static load rating C_{0a} (kN)	7.6	7.6	7.6
Preload torque (N-m)	9.8×10^3 to 6.9×10^2	—	—
Spacer ball	None	None	None
Rigidity value (N/ μ m)	190		
Circulation method	Deflector		

Unit: mm

	Runout of the screw shaft axis D	Runout of the nut circumference H	Flange perpendicularity I	Runout of the thread groove surface J	Lead angle accuracy		Nut mass kg	Shaft mass kg/m
					Representative travel distance error	Fluctuation		
	0.025	0.01	0.008	0.009	± 0.01	0.008	0.13	0.8
	0.03	0.012	0.01	0.012	± 0.02	0.018	0.13	0.8
	0.045	0.02	0.014	0.014	Travel distance: $\pm 0.05/300$		0.13	0.8
	0.025	0.01	0.008	0.009	± 0.01	0.008	0.13	0.8
	0.03	0.012	0.01	0.012	± 0.02	0.018	0.13	0.8
	0.045	0.02	0.014	0.014	Travel distance: $\pm 0.05/300$		0.13	0.8
	0.03	0.01	0.008	0.009	± 0.012	0.008	0.13	0.8
	0.04	0.012	0.01	0.012	± 0.023	0.018	0.13	0.8
	0.055	0.02	0.014	0.014	Travel distance: $\pm 0.05/300$		0.13	0.8
	0.04	0.01	0.008	0.009	± 0.013	0.01	0.13	0.8
	0.05	0.012	0.01	0.012	± 0.025	0.02	0.13	0.8
	0.06	0.02	0.014	0.014	Travel distance: $\pm 0.05/300$		0.13	0.8
	0.045	0.01	0.008	0.009	± 0.015	0.01	0.13	0.8
	0.055	0.012	0.01	0.012	± 0.027	0.02	0.13	0.8
	0.075	0.02	0.014	0.014	Travel distance: $\pm 0.05/300$		0.13	0.8

BNK1408-2.5 Shaft diameter: 14; lead: 8

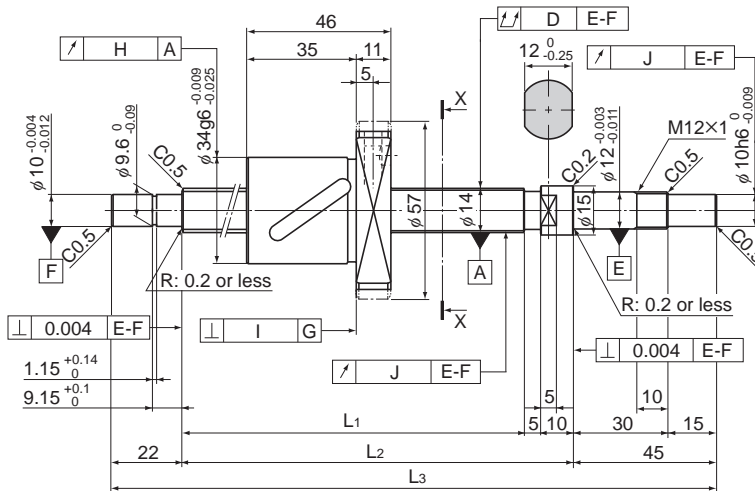

Model No.	Stroke	Screw shaft length		
		L ₁	L ₂	L ₃
BNK 1408-2.5RRG0+321LC5Y	150	239	254	321
BNK 1408-2.5RRG2+321LC7Y				
BNK 1408-2.5RRG0+371LC5Y	200	289	304	371
BNK 1408-2.5RRG2+371LC7Y				
BNK 1408-2.5RRG0+421LC5Y	250	339	354	421
BNK 1408-2.5RRG2+421LC7Y				
BNK 1408-2.5RRG0+471LC5Y	300	389	404	471
BNK 1408-2.5RRG2+471LC7Y				
BNK 1408-2.5RRG0+521LC5Y	350	439	454	521
BNK 1408-2.5RRG2+521LC7Y				
BNK 1408-2.5RRG0+571LC5Y	400	489	504	571
BNK 1408-2.5RRG2+571LC7Y				
BNK 1408-2.5RRG0+621LC5Y	450	539	554	621
BNK 1408-2.5RRG2+621LC7Y				
BNK 1408-2.5RRG0+671LC5Y	500	589	604	671
BNK 1408-2.5RRG2+671LC7Y				
BNK 1408-2.5RRG0+721LC5Y	550	639	654	721
BNK 1408-2.5RRG2+721LC7Y				
BNK 1408-2.5RRG0+771LC5Y	600	689	704	771
BNK 1408-2.5RRG2+771LC7Y				
BNK 1408-2.5RRG0+871LC5Y	700	789	804	871
BNK 1408-2.5RRG2+871LC7Y				

Note) For accuracy grade C5, clearance GT is also standardized.
Plug the unused oil hole before using the product.

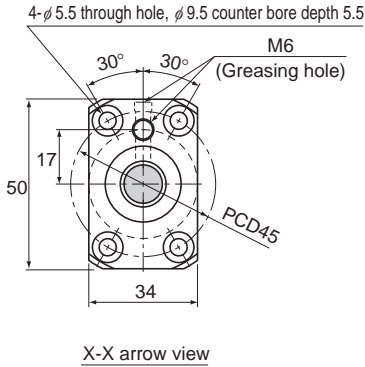

Ball Screw Specifications			
Lead (mm)	8		
BCD (mm)	14.75		
Thread minor diameter (mm)	11.2		
Threading direction, No. of threaded grooves	Rightward, 1		
No. of circuits	2.5 turns × 1 row		
Clearance symbol	G0	GT	G2
Axial clearance (mm)	0	0.005 or less	0.02 or less
Basic dynamic load rating C_a (kN)	4.3	6.9	6.9
Basic static load rating C_{0a} (kN)	5.8	11.5	11.5
Preload torque (N-m)	2×10^2 to 7.8×10^2	—	—
Spacer ball	1 : 1	None	None
Rigidity value (N/μm)	80	150	
Circulation method	Return pipe		

Unit: mm

	Runout of the screw shaft axis	Runout of the nut circumference	Flange perpendicularity	Runout of the thread groove surface	Lead angle accuracy		Nut mass kg	Shaft mass kg/m
					Representative travel distance error	Fluctuation		
	D	H	I	J				
	0.035	0.015	0.011	0.012	±0.023	0.018	0.29	0.84
	0.055	0.03	0.018	0.014	Travel distance: ±0.05/300		0.29	0.84
	0.035	0.015	0.011	0.012	±0.023	0.018	0.29	0.84
	0.055	0.03	0.018	0.014	Travel distance: ±0.05/300		0.29	0.84
	0.04	0.015	0.011	0.012	±0.025	0.02	0.29	0.84
	0.06	0.03	0.018	0.014	Travel distance: ±0.05/300		0.29	0.84
	0.04	0.015	0.011	0.012	±0.025	0.02	0.29	0.84
	0.06	0.03	0.018	0.014	Travel distance: ±0.05/300		0.29	0.84
	0.05	0.015	0.011	0.012	±0.027	0.02	0.29	0.84
	0.075	0.03	0.018	0.014	Travel distance: ±0.05/300		0.29	0.84
	0.05	0.015	0.011	0.012	±0.027	0.02	0.29	0.84
	0.075	0.03	0.018	0.014	Travel distance: ±0.05/300		0.29	0.84
	0.05	0.015	0.011	0.012	±0.03	0.023	0.29	0.84
	0.075	0.03	0.018	0.014	Travel distance: ±0.05/300		0.29	0.84
	0.065	0.015	0.011	0.012	±0.03	0.023	0.29	0.84
	0.09	0.03	0.018	0.014	Travel distance: ±0.05/300		0.29	0.84
	0.065	0.015	0.011	0.012	±0.035	0.025	0.29	0.84
	0.09	0.03	0.018	0.014	Travel distance: ±0.05/300		0.29	0.84
	0.065	0.015	0.011	0.012	±0.035	0.025	0.29	0.84
	0.09	0.03	0.018	0.014	Travel distance: ±0.05/300		0.29	0.84
	0.085	0.015	0.011	0.012	±0.035	0.025	0.29	0.84
	0.12	0.03	0.018	0.014	Travel distance: ±0.05/300		0.29	0.84

BNK1510-5.6 Shaft diameter: 15; lead: 10

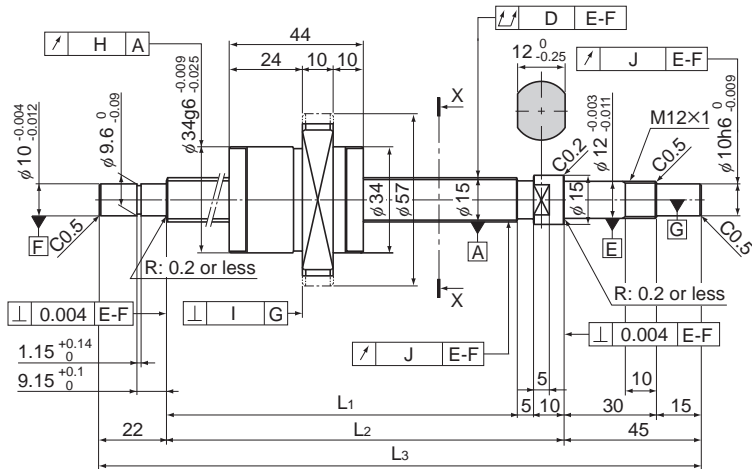

Model No.	Stroke	Screw shaft length		
		L ₁	L ₂	L ₃
BNK 1510-5.6G0+321LC5Y	150	239	254	321
BNK 1510-5.6G2+321LC7Y				
BNK 1510-5.6G0+371LC5Y	200	289	304	371
BNK 1510-5.6G2+371LC7Y				
BNK 1510-5.6G0+421LC5Y	250	339	354	421
BNK 1510-5.6G2+421LC7Y				
BNK 1510-5.6G0+471LC5Y	300	389	404	471
BNK 1510-5.6G2+471LC7Y				
BNK 1510-5.6G0+521LC5Y	350	439	454	521
BNK 1510-5.6G2+521LC7Y				
BNK 1510-5.6G0+571LC5Y	400	489	504	571
BNK 1510-5.6G2+571LC7Y				
BNK 1510-5.6G0+621LC5Y	450	539	554	621
BNK 1510-5.6G2+621LC7Y				
BNK 1510-5.6G0+671LC5Y	500	589	604	671
BNK 1510-5.6G2+671LC7Y				
BNK 1510-5.6G0+721LC5Y	550	639	654	721
BNK 1510-5.6G2+721LC7Y				
BNK 1510-5.6G0+771LC5Y	600	689	704	771
BNK 1510-5.6G2+771LC7Y				
BNK 1510-5.6G0+871LC5Y	700	789	804	871
BNK 1510-5.6G2+871LC7Y				
BNK 1510-5.6G0+971LC5Y	800	889	904	971
BNK 1510-5.6G2+971LC7Y				

Note) For accuracy grade C5, clearance GT is also standardized.

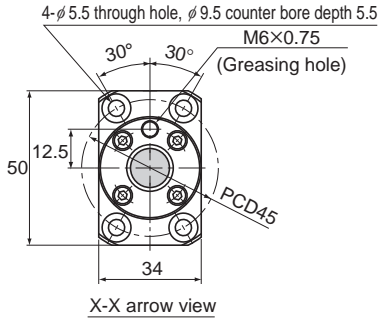

Ball Screw Specifications			
Lead (mm)	10		
BCD (mm)	15.75		
Thread minor diameter (mm)	12.5		
Threading direction, No. of threaded grooves	Rightward, 2		
No. of circuits	2.8 turns × 2 rows		
Clearance symbol	G0	GT	G2
Axial clearance (mm)	0	0.005 or less	0.02 or less
Basic dynamic load rating C_a (kN)	9	14.3	14.3
Basic static load rating C_{0a} (kN)	13.9	27.9	27.9
Preload torque (N-m)	2×10^2 to 9.8×10^2	—	—
Spacer ball	1 : 1	None	None
Rigidity value (N/μm)	190	350	
Circulation method	End cap		

Unit: mm

	Runout of the screw shaft axis D	Runout of the nut circumference H	Flange perpendicularity I	Runout of the thread groove surface J	Lead angle accuracy		Nut mass kg	Shaft mass kg/m
					Representative travel distance error	Fluctuation		
	0.035	0.015	0.011	0.012	±0.023	0.018	0.22	0.76
	0.055	0.03	0.018	0.014	Travel distance: ±0.05/300		0.22	0.76
	0.035	0.015	0.011	0.012	±0.023	0.018	0.22	0.76
	0.055	0.03	0.018	0.014	Travel distance: ±0.05/300		0.22	0.76
	0.04	0.015	0.011	0.012	±0.025	0.02	0.22	0.76
	0.06	0.03	0.018	0.014	Travel distance: ±0.05/300		0.22	0.76
	0.04	0.015	0.011	0.012	±0.025	0.02	0.22	0.76
	0.06	0.03	0.018	0.014	Travel distance: ±0.05/300		0.22	0.76
	0.05	0.015	0.011	0.012	±0.027	0.02	0.22	0.76
	0.075	0.03	0.018	0.014	Travel distance: ±0.05/300		0.22	0.76
	0.05	0.015	0.011	0.012	±0.027	0.02	0.22	0.76
	0.075	0.03	0.018	0.014	Travel distance: ±0.05/300		0.22	0.76
	0.05	0.015	0.011	0.012	±0.03	0.023	0.22	0.76
	0.075	0.03	0.018	0.014	Travel distance: ±0.05/300		0.22	0.76
	0.065	0.015	0.011	0.012	±0.03	0.023	0.22	0.76
	0.09	0.03	0.018	0.014	Travel distance: ±0.05/300		0.22	0.76
	0.065	0.015	0.011	0.012	±0.035	0.025	0.22	0.76
	0.09	0.03	0.018	0.014	Travel distance: ±0.05/300		0.22	0.76
	0.065	0.015	0.011	0.012	±0.035	0.025	0.22	0.76
	0.09	0.03	0.018	0.014	Travel distance: ±0.05/300		0.22	0.76
	0.085	0.015	0.011	0.012	±0.035	0.025	0.22	0.76
	0.12	0.03	0.018	0.014	Travel distance: ±0.05/300		0.22	0.76
	0.085	0.015	0.011	0.012	±0.04	0.027	0.22	0.76
	0.12	0.03	0.018	0.014	Travel distance: ±0.05/300		0.22	0.76

BNK1520-3 Shaft diameter: 15; lead: 20

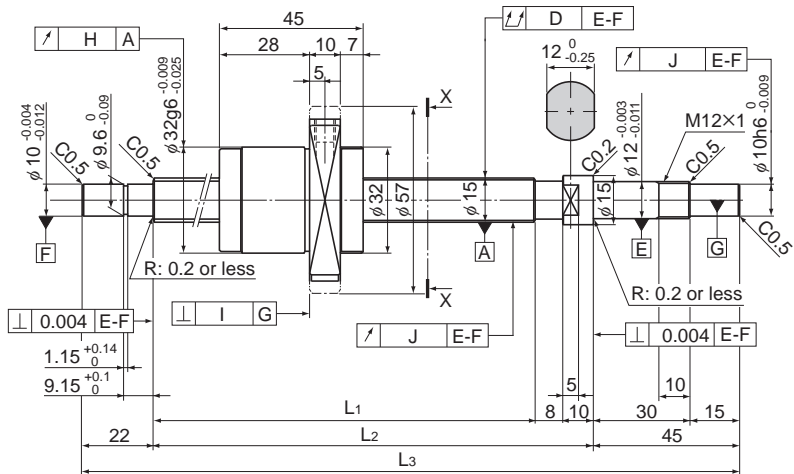

Model No.	Stroke	Screw shaft length		
		L ₁	L ₂	L ₃
BNK 1520-3G0+321LC5Y	150	236	254	321
BNK 1520-3G2+321LC7Y				
BNK 1520-3G0+371LC5Y				
BNK 1520-3G2+371LC7Y	200	286	304	371
BNK 1520-3G0+421LC5Y				
BNK 1520-3G2+421LC7Y				
BNK 1520-3G0+471LC5Y	250	336	354	421
BNK 1520-3G2+471LC7Y				
BNK 1520-3G0+521LC5Y				
BNK 1520-3G2+521LC7Y	300	436	454	521
BNK 1520-3G0+571LC5Y				
BNK 1520-3G2+571LC7Y				
BNK 1520-3G0+621LC5Y	350	486	504	571
BNK 1520-3G2+621LC7Y				
BNK 1520-3G0+671LC5Y				
BNK 1520-3G2+671LC7Y	400	536	554	621
BNK 1520-3G0+721LC5Y				
BNK 1520-3G2+721LC7Y				
BNK 1520-3G0+771LC5Y	450	586	604	671
BNK 1520-3G2+771LC7Y				
BNK 1520-3G0+871LC5Y				
BNK 1520-3G2+871LC7Y	500	636	654	721
BNK 1520-3G0+971LC5Y				
BNK 1520-3G2+971LC7Y				
BNK 1520-3G0+771LC5Y	550	686	704	771
BNK 1520-3G2+771LC7Y				
BNK 1520-3G0+871LC5Y				
BNK 1520-3G2+871LC7Y	600	786	804	871
BNK 1520-3G0+971LC5Y				
BNK 1520-3G2+971LC7Y				
BNK 1520-3G0+971LC5Y	700	886	904	971
BNK 1520-3G2+971LC7Y				

Note) For accuracy grade C5, clearance GT is also standardized.

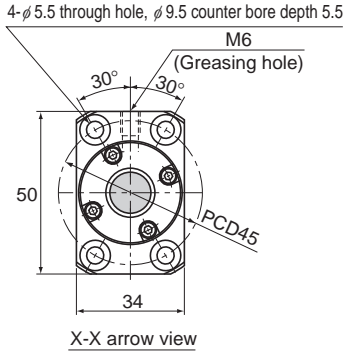

Ball Screw Specifications			
Lead (mm)	20		
BCD (mm)	15.75		
Thread minor diameter (mm)	12.5		
Threading direction, No. of threaded grooves	Rightward, 2		
No. of circuits	1.5 turns \times 2 rows		
Clearance symbol	G0	GT	G2
Axial clearance (mm)	0	0.005 or less	0.02 or less
Basic dynamic load rating C_a (kN)	5.1	8	8
Basic static load rating C_{0a} (kN)	7.9	15.8	15.8
Preload torque (N-m)	2×10^2 to 8.8×10^2	—	—
Spacer ball	1 : 1	None	None
Rigidity value (N/ μ m)	110	200	
Circulation method	End cap		

Unit: mm

	Runout of the screw shaft axis	Runout of the nut circumference	Flange perpendicularity	Runout of the thread groove surface	Lead angle accuracy		Nut mass kg	Shaft mass kg/m
					Representative travel distance error	Fluctuation		
	D	H	I	J				
	0.035	0.015	0.011	0.012	± 0.023	0.018	0.32	1.05
	0.055	0.03	0.018	0.014	Travel distance: $\pm 0.05/300$		0.32	1.05
	0.035	0.015	0.011	0.012	± 0.023	0.018	0.32	1.05
	0.055	0.03	0.018	0.014	Travel distance: $\pm 0.05/300$		0.32	1.05
	0.04	0.015	0.011	0.012	± 0.025	0.02	0.32	1.05
	0.06	0.03	0.018	0.014	Travel distance: $\pm 0.05/300$		0.32	1.05
	0.04	0.015	0.011	0.012	± 0.025	0.02	0.32	1.05
	0.06	0.03	0.018	0.014	Travel distance: $\pm 0.05/300$		0.32	1.05
	0.05	0.015	0.011	0.012	± 0.027	0.02	0.32	1.05
	0.075	0.03	0.018	0.014	Travel distance: $\pm 0.05/300$		0.32	1.05
	0.05	0.015	0.011	0.012	± 0.027	0.02	0.32	1.05
	0.075	0.03	0.018	0.014	Travel distance: $\pm 0.05/300$		0.32	1.05
	0.05	0.015	0.011	0.012	± 0.03	0.023	0.32	1.05
	0.075	0.03	0.018	0.014	Travel distance: $\pm 0.05/300$		0.32	1.05
	0.065	0.015	0.011	0.012	± 0.03	0.023	0.32	1.05
	0.09	0.03	0.018	0.014	Travel distance: $\pm 0.05/300$		0.32	1.05
	0.065	0.015	0.011	0.012	± 0.035	0.025	0.32	1.05
	0.09	0.03	0.018	0.014	Travel distance: $\pm 0.05/300$		0.32	1.05
	0.065	0.015	0.011	0.012	± 0.035	0.025	0.32	1.05
	0.09	0.03	0.018	0.014	Travel distance: $\pm 0.05/300$		0.32	1.05
	0.085	0.015	0.011	0.012	± 0.035	0.025	0.32	1.05
	0.12	0.03	0.018	0.014	Travel distance: $\pm 0.05/300$		0.32	1.05
	0.085	0.015	0.011	0.012	± 0.04	0.027	0.32	1.05
	0.12	0.03	0.018	0.014	Travel distance: $\pm 0.05/300$		0.32	1.05

BNK1616-3.6 Shaft diameter: 16; lead: 16

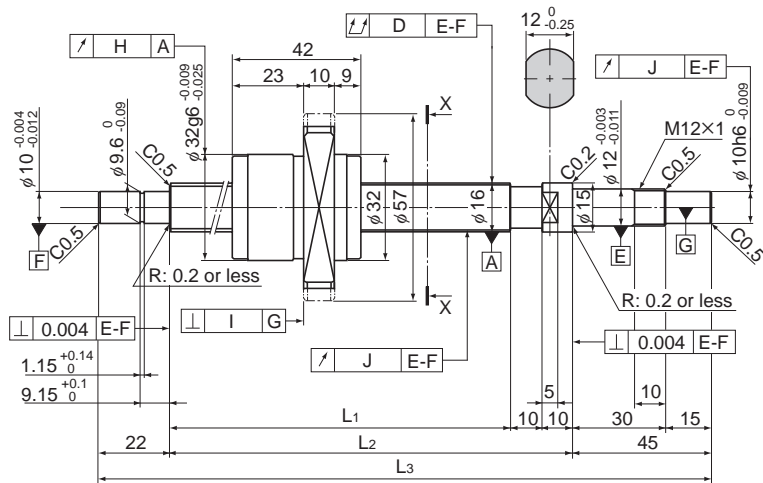

Model No.	Stroke	Screw shaft length		
		L ₁	L ₂	L ₃
BNK 1616-3.6G0+321LC5Y	150	234	254	321
BNK 1616-3.6G2+321LC7Y				
BNK 1616-3.6G0+371LC5Y	200	284	304	371
BNK 1616-3.6G2+371LC7Y				
BNK 1616-3.6G0+421LC5Y	250	334	354	421
BNK 1616-3.6G2+421LC7Y				
BNK 1616-3.6G0+471LC5Y	300	384	404	471
BNK 1616-3.6G2+471LC7Y				
BNK 1616-3.6G0+521LC5Y	350	434	454	521
BNK 1616-3.6G2+521LC7Y				
BNK 1616-3.6G0+571LC5Y	400	484	504	571
BNK 1616-3.6G2+571LC7Y				
BNK 1616-3.6G0+621LC5Y	450	534	554	621
BNK 1616-3.6G2+621LC7Y				
BNK 1616-3.6G0+671LC5Y	500	584	604	671
BNK 1616-3.6G2+671LC7Y				
BNK 1616-3.6G0+721LC5Y	550	634	654	721
BNK 1616-3.6G2+721LC7Y				
BNK 1616-3.6G0+771LC5Y	600	684	704	771
BNK 1616-3.6G2+771LC7Y				
BNK 1616-3.6G0+871LC5Y	700	784	804	871
BNK 1616-3.6G2+871LC7Y				
BNK 1616-3.6G0+971LC5Y	800	884	904	971
BNK 1616-3.6G2+971LC7Y				

Note) For accuracy grade C5, clearance GT is also standardized.

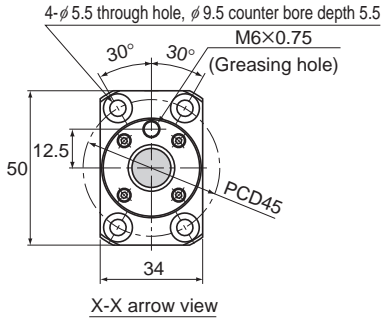

Ball Screw Specifications			
Lead (mm)	16		
BCD (mm)	16.65		
Thread minor diameter (mm)	13.7		
Threading direction, No. of threaded grooves	Rightward, 2		
No. of circuits	1.8 turns × 2 rows		
Clearance symbol	G0	GT	G2
Axial clearance (mm)	0	0.005 or less	0.02 or less
Basic dynamic load rating C_a (kN)	4.4	7.1	7.1
Basic static load rating C_{0a} (kN)	7.2	14.3	14.3
Preload torque (N-m)	2×10^2 to 9.8×10^2	—	—
Spacer ball	1 : 1	None	None
Rigidity value (N/μm)	120	230	
Circulation method	End cap		

Unit: mm

	Runout of the screw shaft axis D	Runout of the nut circumference H	Flange perpendicularity I	Runout of the thread groove surface J	Lead angle accuracy		Nut mass kg	Shaft mass kg/m
					Representative travel distance error	Fluctuation		
	0.035	0.015	0.011	0.012	±0.023	0.018	0.2	1.25
	0.055	0.03	0.018	0.014	Travel distance: ±0.05/300		0.2	1.25
	0.035	0.015	0.011	0.012	±0.023	0.018	0.2	1.25
	0.055	0.03	0.018	0.014	Travel distance: ±0.05/300		0.2	1.25
	0.04	0.015	0.011	0.012	±0.025	0.02	0.2	1.25
	0.06	0.03	0.018	0.014	Travel distance: ±0.05/300		0.2	1.25
	0.04	0.015	0.011	0.012	±0.025	0.02	0.2	1.25
	0.06	0.03	0.018	0.014	Travel distance: ±0.05/300		0.2	1.25
	0.05	0.015	0.011	0.012	±0.027	0.02	0.2	1.25
	0.075	0.03	0.018	0.014	Travel distance: ±0.05/300		0.2	1.25
	0.05	0.015	0.011	0.012	±0.027	0.02	0.2	1.25
	0.075	0.03	0.018	0.014	Travel distance: ±0.05/300		0.2	1.25
	0.05	0.015	0.011	0.012	±0.03	0.023	0.2	1.25
	0.075	0.03	0.018	0.014	Travel distance: ±0.05/300		0.2	1.25
	0.065	0.015	0.011	0.012	±0.03	0.023	0.2	1.25
	0.09	0.03	0.018	0.014	Travel distance: ±0.05/300		0.2	1.25
	0.065	0.015	0.011	0.012	±0.035	0.025	0.2	1.25
	0.09	0.03	0.018	0.014	Travel distance: ±0.05/300		0.2	1.25
	0.065	0.015	0.011	0.012	±0.035	0.025	0.2	1.25
	0.09	0.03	0.018	0.014	Travel distance: ±0.05/300		0.2	1.25
	0.085	0.015	0.011	0.012	±0.035	0.025	0.2	1.25
	0.12	0.03	0.018	0.014	Travel distance: ±0.05/300		0.2	1.25
	0.085	0.015	0.011	0.012	±0.04	0.027	0.2	1.25
	0.12	0.03	0.018	0.014	Travel distance: ±0.05/300		0.2	1.25

BNK2010-2.5 Shaft diameter: 20; lead: 10

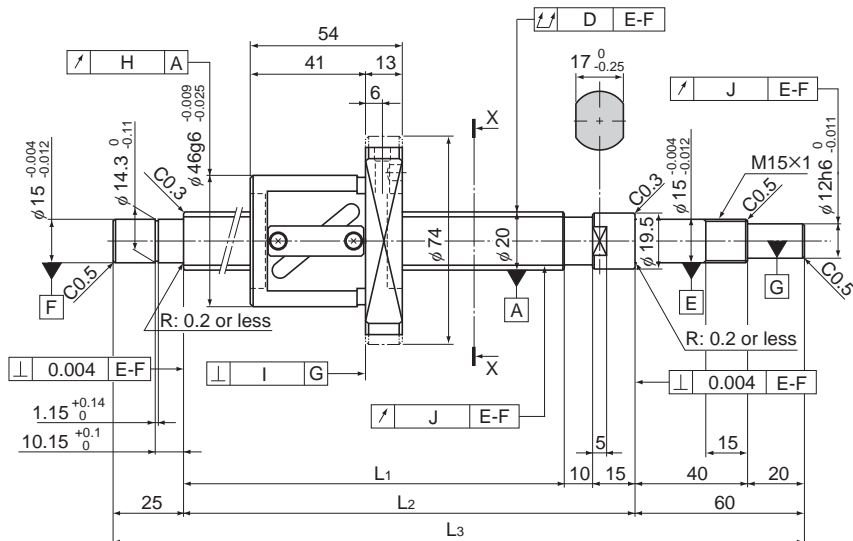

Model No.	Stroke	Screw shaft length		
		L ₁	L ₂	L ₃
BNK 2010-2.5RRG0+499LC5Y	300	389	414	499
BNK 2010-2.5RRG2+499LC7Y				
BNK 2010-2.5RRG0+599LC5Y	400	489	514	599
BNK 2010-2.5RRG2+599LC7Y				
BNK 2010-2.5RRG0+699LC5Y	500	589	614	699
BNK 2010-2.5RRG2+699LC7Y				
BNK 2010-2.5RRG0+799LC5Y	600	689	714	799
BNK 2010-2.5RRG2+799LC7Y				
BNK 2010-2.5RRG0+899LC5Y	700	789	814	899
BNK 2010-2.5RRG2+899LC7Y				
BNK 2010-2.5RRG0+999LC5Y	800	889	914	999
BNK 2010-2.5RRG2+999LC7Y				
BNK 2010-2.5RRG0+1099LC5Y	900	989	1014	1099
BNK 2010-2.5RRG2+1099LC7Y				
BNK 2010-2.5RRG0+1199LC5Y	1000	1089	1114	1199
BNK 2010-2.5RRG2+1199LC7Y				
BNK 2010-2.5RRG0+1299LC5Y	1100	1189	1214	1299
BNK 2010-2.5RRG2+1299LC7Y				

Note) For accuracy grade C5, clearance GT is also standardized.
Plug the unused oil hole before using the product.

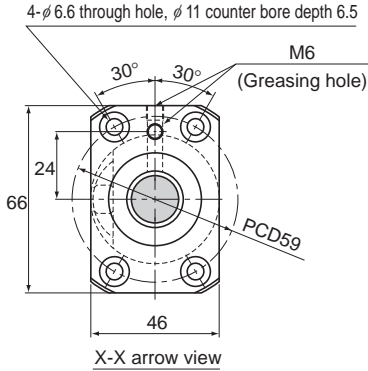

Ball Screw Specifications			
Lead (mm)	10		
BCD (mm)	21		
Thread minor diameter (mm)	16.4		
Threading direction, No. of threaded grooves	Rightward, 1		
No. of circuits	2.5 turns \times 1 row		
Clearance symbol	G0	GT	G2
Axial clearance (mm)	0	0.005 or less	0.02 or less
Basic dynamic load rating C_a (kN)	7	11.1	11.1
Basic static load rating C_{0a} (kN)	11	22	22
Preload torque (N-m)	2×10^2 to 9.8×10^2	—	—
Spacer ball	1 : 1	None	None
Rigidity value (N/ μ m)	110	210	
Circulation method	Return pipe		

Unit: mm

	Runout of the screw shaft axis	Runout of the nut circumference	Flange perpendicularity	Runout of the thread groove surface	Lead angle accuracy		Nut mass kg	Shaft mass kg/m
					Representative travel distance error	Fluctuation		
	D	H	I	J				
	0.04	0.015	0.011	0.012	± 0.025	0.02	0.58	1.81
	0.06	0.03	0.018	0.014	Travel distance: $\pm 0.05/300$		0.58	1.81
	0.05	0.015	0.011	0.012	± 0.027	0.02	0.58	1.81
	0.075	0.03	0.018	0.014	Travel distance: $\pm 0.05/300$		0.58	1.81
	0.065	0.015	0.011	0.012	± 0.03	0.023	0.58	1.81
	0.09	0.03	0.018	0.014	Travel distance: $\pm 0.05/300$		0.58	1.81
	0.065	0.015	0.011	0.012	± 0.035	0.025	0.58	1.81
	0.09	0.03	0.018	0.014	Travel distance: $\pm 0.05/300$		0.58	1.81
	0.085	0.015	0.011	0.012	± 0.035	0.025	0.58	1.81
	0.12	0.03	0.018	0.014	Travel distance: $\pm 0.05/300$		0.58	1.81
	0.085	0.015	0.011	0.012	± 0.04	0.027	0.58	1.81
	0.12	0.03	0.018	0.014	Travel distance: $\pm 0.05/300$		0.58	1.81
	0.11	0.015	0.011	0.012	± 0.04	0.027	0.58	1.81
	0.15	0.03	0.018	0.014	Travel distance: $\pm 0.05/300$		0.58	1.81
	0.11	0.015	0.011	0.012	± 0.046	0.03	0.58	1.81
	0.15	0.03	0.018	0.014	Travel distance: $\pm 0.05/300$		0.58	1.81
	0.15	0.015	0.011	0.012	± 0.046	0.03	0.58	1.81
	0.19	0.03	0.018	0.014	Travel distance: $\pm 0.05/300$		0.58	1.81

BNK2020-3.6 Shaft diameter: 20; lead: 20

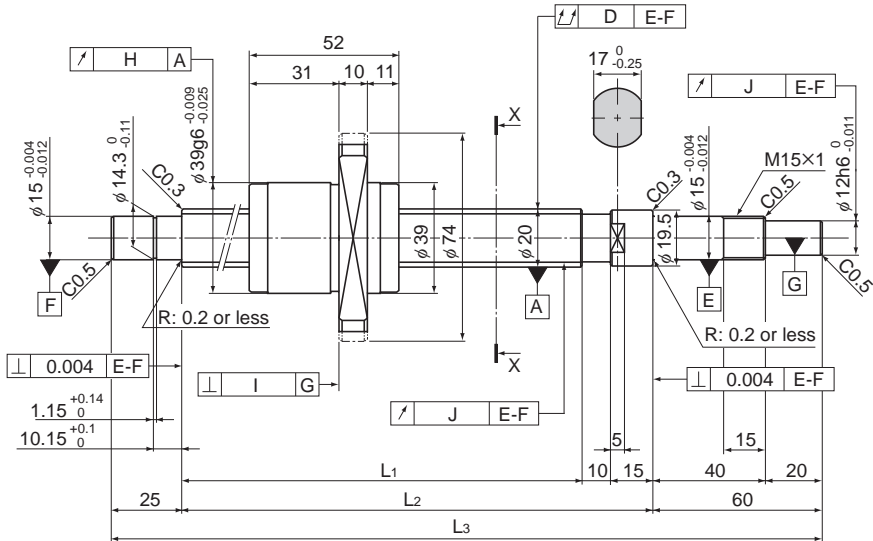

Model No.	Stroke	Screw shaft length		
		L ₁	L ₂	L ₃
BNK 2020-3.6G0+520LC5Y	300	410	435	520
BNK 2020-3.6G2+520LC7Y				
BNK 2020-3.6G0+620LC5Y	400	510	535	620
BNK 2020-3.6G2+620LC7Y				
BNK 2020-3.6G0+720LC5Y	500	610	635	720
BNK 2020-3.6G2+720LC7Y				
BNK 2020-3.6G0+820LC5Y	600	710	735	820
BNK 2020-3.6G2+820LC7Y				
BNK 2020-3.6G0+920LC5Y	700	810	835	920
BNK 2020-3.6G2+920LC7Y				
BNK 2020-3.6G0+1020LC5Y	800	910	935	1020
BNK 2020-3.6G2+1020LC7Y				
BNK 2020-3.6G0+1120LC5Y	900	1010	1035	1120
BNK 2020-3.6G2+1120LC7Y				
BNK 2020-3.6G0+1220LC5Y	1000	1110	1135	1220
BNK 2020-3.6G2+1220LC7Y				
BNK 2020-3.6G0+1320LC5Y	1100	1210	1235	1320
BNK 2020-3.6G2+1320LC7Y				

Note) For accuracy grade C5, clearance GT is also standardized.

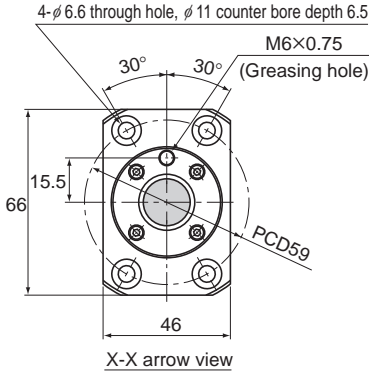

Ball Screw Specifications			
Lead (mm)	20		
BCD (mm)	20.75		
Thread minor diameter (mm)	17.5		
Threading direction, No. of threaded grooves	Rightward, 2		
No. of circuits	1.8 turns × 2 rows		
Clearance symbol	G0	GT	G2
Axial clearance (mm)	0	0.005 or less	0.02 or less
Basic dynamic load rating C_a (kN)	7	11.1	11.1
Basic static load rating C_{0a} (kN)	12.3	24.7	24.7
Preload torque (N-m)	2×10^2 to 9.8×10^2	—	—
Spacer ball	1 : 1	None	None
Rigidity value (N/μm)	160	290	
Circulation method	End cap		

Unit: mm

	Runout of the screw shaft axis	Runout of the nut circumference	Flange perpendicularity	Runout of the thread groove surface	Lead angle accuracy		Nut mass kg	Shaft mass kg/m
					Representative travel distance error	Fluctuation		
	D	H	I	J				
	0.05	0.015	0.011	0.012	±0.027	0.02	0.39	2.04
	0.075	0.03	0.018	0.014	Travel distance: ±0.05/300		0.39	2.04
	0.05	0.015	0.011	0.012	±0.03	0.023	0.39	2.04
	0.075	0.03	0.018	0.014	Travel distance: ±0.05/300		0.39	2.04
	0.065	0.015	0.011	0.012	±0.03	0.023	0.39	2.04
	0.09	0.03	0.018	0.014	Travel distance: ±0.05/300		0.39	2.04
	0.085	0.015	0.011	0.012	±0.035	0.025	0.39	2.04
	0.12	0.03	0.018	0.014	Travel distance: ±0.05/300		0.39	2.04
	0.085	0.015	0.011	0.012	±0.04	0.027	0.39	2.04
	0.12	0.03	0.018	0.014	Travel distance: ±0.05/300		0.39	2.04
	0.11	0.015	0.011	0.012	±0.04	0.027	0.39	2.04
	0.15	0.03	0.018	0.014	Travel distance: ±0.05/300		0.39	2.04
	0.11	0.015	0.011	0.012	±0.046	0.03	0.39	2.04
	0.15	0.03	0.018	0.014	Travel distance: ±0.05/300		0.39	2.04
	0.11	0.015	0.011	0.012	±0.046	0.03	0.39	2.04
	0.15	0.03	0.018	0.014	Travel distance: ±0.05/300		0.39	2.04
	0.15	0.015	0.011	0.012	±0.046	0.03	0.39	2.04
	0.19	0.03	0.018	0.014	Travel distance: ±0.05/300		0.39	2.04

BNK2520-3.6 Shaft diameter: 25; lead: 20

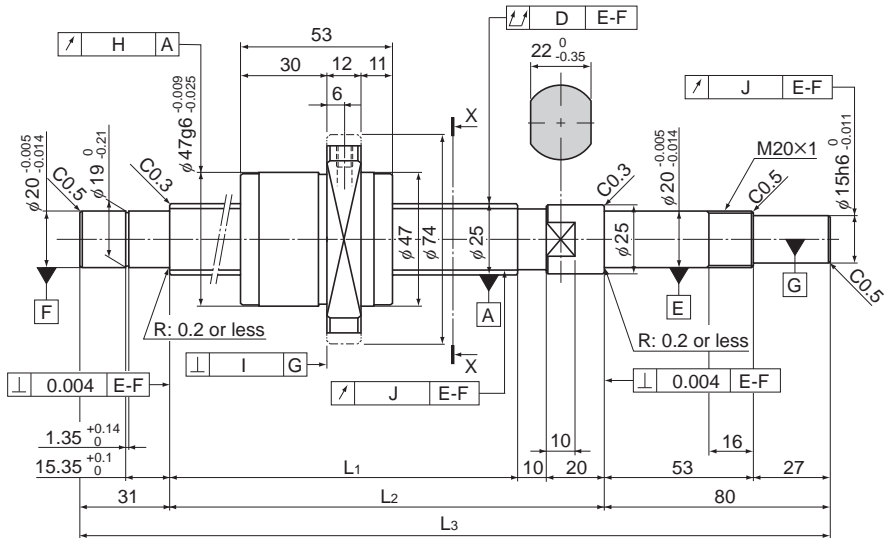

Model No.	Stroke	Screw shaft length		
		L ₁	L ₂	L ₃
BNK 2520-3.6G0+751LC5Y	500	610	640	751
BNK 2520-3.6G2+751LC7Y				
BNK 2520-3.6G0+851LC5Y	600	710	740	851
BNK 2520-3.6G2+851LC7Y				
BNK 2520-3.6G0+1051LC5Y	800	910	940	1051
BNK 2520-3.6G2+1051LC7Y				
BNK 2520-3.6G0+1251LC5Y	1000	1110	1140	1251
BNK 2520-3.6G2+1251LC7Y				
BNK 2520-3.6G0+1451LC5Y	1200	1310	1340	1451
BNK 2520-3.6G2+1451LC7Y				
BNK 2520-3.6G0+1651LC5Y	1400	1510	1540	1651
BNK 2520-3.6G2+1651LC7Y				
BNK 2520-3.6G0+1851LC5Y	1600	1710	1740	1851
BNK 2520-3.6G2+1851LC7Y				

Note) For accuracy grade C5, clearance GT is also standardized.

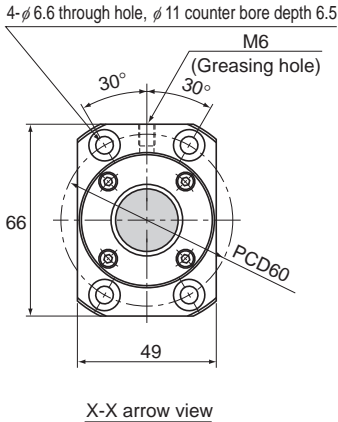

Ball Screw Specifications			
Lead (mm)	20		
BCD (mm)	26		
Thread minor diameter (mm)	21.9		
Threading direction, No. of threaded grooves	Rightward, 2		
No. of circuits	1.8 turns \times 2 rows		
Clearance symbol	G0	GT	G2
Axial clearance (mm)	0	0.005 or less	0.02 or less
Basic dynamic load rating C_a (kN)	10.5	16.7	16.7
Basic static load rating C_{0a} (kN)	19	38	38
Preload torque (N-m)	4.9×10^2 to 2.2×10^1	—	—
Spacer ball	1 : 1	None	None
Rigidity value (N/ μ m)	190	360	
Circulation method	End cap		

Unit: mm

	Runout of the screw shaft axis	Runout of the nut circumference	Flange perpendicularity	Runout of the thread groove surface	Lead angle accuracy		Nut mass kg	Shaft mass kg/m
					Representative travel distance error	Fluctuation		
	D	H	I	J				
	0.055	0.015	0.011	0.013	± 0.03	0.023	0.53	3.03
	0.07	0.03	0.018	0.02	Travel distance: $\pm 0.05/300$		0.53	3.03
	0.065	0.015	0.011	0.013	± 0.035	0.025	0.53	3.03
	0.085	0.03	0.018	0.02	Travel distance: $\pm 0.05/300$		0.53	3.03
	0.085	0.015	0.011	0.013	± 0.04	0.027	0.53	3.03
	0.1	0.03	0.018	0.02	Travel distance: $\pm 0.05/300$		0.53	3.03
	0.11	0.015	0.011	0.013	± 0.046	0.03	0.53	3.03
	0.13	0.03	0.018	0.02	Travel distance: $\pm 0.05/300$		0.53	3.03
	0.11	0.015	0.011	0.013	± 0.054	0.035	0.53	3.03
	0.13	0.03	0.018	0.02	Travel distance: $\pm 0.05/300$		0.53	3.03
	0.14	0.015	0.011	0.013	± 0.054	0.035	0.53	3.03
	0.17	0.03	0.018	0.02	Travel distance: $\pm 0.05/300$		0.53	3.03
	0.14	0.015	0.011	0.013	± 0.065	0.04	0.53	3.03
	0.17	0.03	0.018	0.02	Travel distance: $\pm 0.05/300$		0.53	3.03