

Model RU (Integrated Inner/Outer Ring Type)

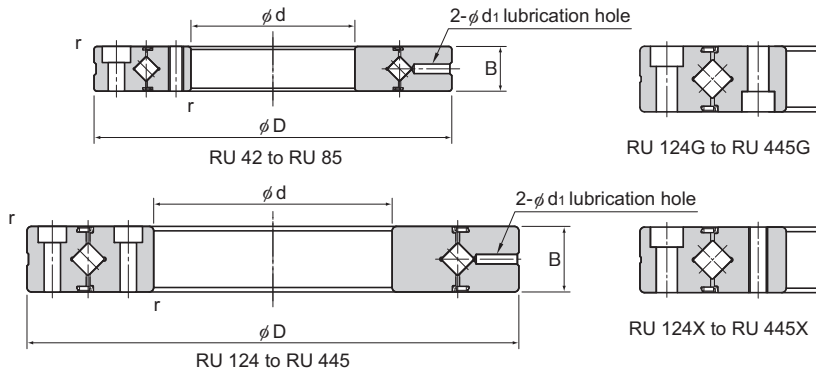

Shaft diameter	Model No.	Main dimensions						Shoulder height		Basic load rating (radial)		Mass
		Inner diameter d	Outer diameter D	Roller pitch circle diameter dp	Width B	Lubrication hole d ₁	r _{min}	ds (max)	Dh (min)	C	C ₀	
20	RU 42	20	70	41.5	12	3.1	0.6	36	47	7.35	8.35	0.29
35	RU 66	35	95	66	15	3.1	0.6	59	74	17.5	22.3	0.62
55	RU 85	55	120	85	15	3.1	0.6	77	93	20.3	29.5	1
80	RU 124 (G)	80	165	124	22	3.1	1	114	134	33.1	50.9	2.6
	RU 124X											
90	RU 148 (G)	90	210	147.5	25	3.1	1.5	133	162	49.1	76.8	4.9
	RU 148X											
115	RU 178 (G)	115	240	178	28	3.1	1.5	161	195	80.3	135	6.8
	RU 178X											
160	RU 228 (G)	160	295	227.5	35	6	2	208	246	104	173	11.4
	RU 228X											
210	RU 297 (G)	210	380	297.3	40	6	2.5	272	320	156	281	21.3
	RU 297X											
350	RU 445 (G)	350	540	445.4	45	6	2.5	417	473	222	473	35.4
	RU 445X											

Note) Optional grease nipple available for model RU. (See figure below.)

To indicate that you want grease nipples, add "-N" to the end of the model number.

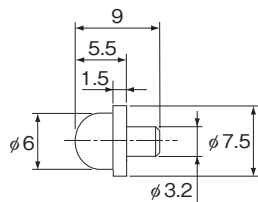

NP3.2×3.5

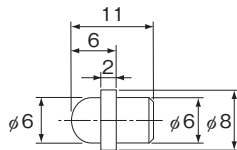

NP6×5

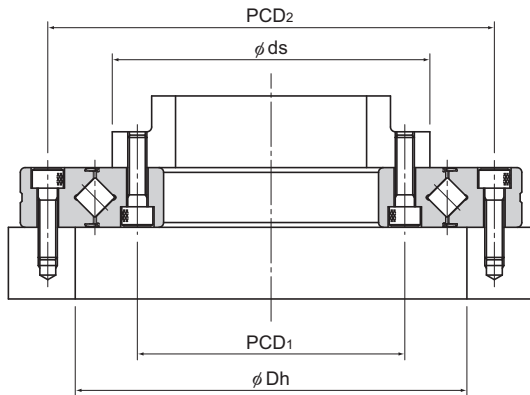

Model RU

Model RU...U



Model RU...UU

Model RU...UT

Unit: mm

Mounting Hole Related				
Inner ring			Outer ring	
PCD ₁	Mounting hole	PCD ₂	Mounting hole	
28	6-M3 through	57	6-φ3.4 drilled through, φ6.5 counter bore depth 3.3	
45	8-M4 through	83	8-φ4.5 drilled through, φ8 counter bore depth 4.4	
65	8-M5 through	105	8-φ5.5 drilled through, φ9.5 counter bore depth 5.4	
97	10-φ5.5 drilled through, φ9.5 counter bore depth 5.4 10-M5 through	148	10-φ5.5 drilled through, φ9.5 counter bore depth 5.4	
112	12-φ9 drilled through, φ14 counter bore depth 8.6 12-M8 through	187	12-φ9 drilled through, φ14 counter bore depth 8.6	
139	12-φ9 drilled through, φ14 counter bore depth 8.6 12-M8 through	217	12-φ9 drilled through, φ14 counter bore depth 8.6	
184	12-φ11 drilled through, φ17.5 counter bore depth 10.8 12-M10 through	270	12-φ11 drilled through, φ17.5 counter bore depth 10.8	
240	16-φ14 drilled through, φ20 counter bore depth 13 16-M12 through	350	16-φ14 drilled through, φ20 counter bore depth 13	
385	24-φ14 drilled through, φ20 counter bore depth 13 24-M12 through	505	24-φ14 drilled through, φ20 counter bore depth 13	

Model number coding

RU124 UU CC0 P2 B G -N

Model No.

Accuracy symbol (*2)

Radial clearance symbol (*1)

Sub-part Accuracy symbol

No Symbol : Rotational Accuracy of the Inner Ring

R : Rotational Accuracy of the Outer Ring

B : Rotational Accuracy of the Inner/Outer Rings

Grease nipple symbol

No Symbol : No grease nipples included

-N : Grease nipples attached (2)

(For the nipple's shape,

see the figure on the left.)

RU42 to RU178: NP3.2 × 3.5

RU228 to RU445: NP6 × 5

Seal symbol

No Symbol : Without seal

UU : Seal attached on both ends
U : Seal attached on either end
(counterbore side of the outer ring)UT : Seal attached on either end
(opposite to the counterbore
side of the outer ring)

Mounting Hole Symbol

[Applicable Models : RU124 to RU445(RU42 to RU85 do not apply)]

No Symbol : The counterbore holes of the inner and outer rings

face the same direction

G : The counterbore holes of the inner and outer rings

face opposite direction

X : Inner ring tapped hole (through hole)

(*1) See A18-18. (*2) See A18-12.

Model RB (Separable Outer Ring Type)

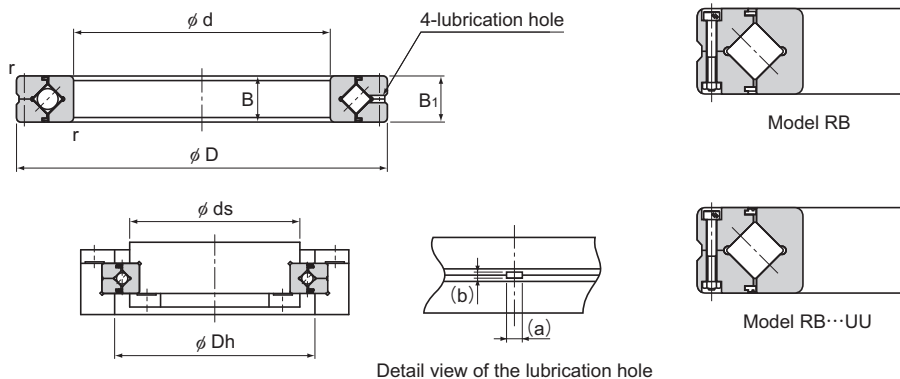

Unit: mm

Shaft diameter	Model No.	Main dimensions							Shoulder height		Basic load rating (radial)		Mass
		Inner diameter d	Outer diameter D	Roller pitch circle diameter dp	Width B B ₁	Lubrication hole		r_{min}	ds (max)	Dh (min)	C	C ₀	
						a	b						
20	RB 2008	20	36	27	8	2	0.8	0.5	23.5	30.5	3.23	3.1	0.04
25	RB 2508	25	41	32	8	2	0.8	0.5	28.5	35.5	3.63	3.83	0.05
30	RB 3010	30	55	41.5	10	2.5	1	0.6	37	47	7.35	8.36	0.12
35	RB 3510	35	60	46.5	10	2.5	1	0.6	41	51.5	7.64	9.12	0.13
40	RB 4010	40	65	51.5	10	2.5	1	0.6	46.5	57.5	8.33	10.6	0.16
45	RB 4510	45	70	56.5	10	2.5	1	0.6	51	61.5	8.62	11.3	0.17
50	RB 5013	50	80	64	13	2.5	1.6	0.6	57	72	16.7	20.9	0.27
60	RB 6013	60	90	74	13	2.5	1.6	0.6	67	82	18	24.3	0.3
70	RB 7013	70	100	84	13	2.5	1.6	0.6	77	92	19.4	27.7	0.35
80	RB 8016	80	120	98	16	3	1.6	0.6	88	110	30.1	42.1	0.7
90	RB 9016	90	130	108	16	3	1.6	1	98	118	31.4	45.3	0.75
100	RB 10016	100	140	119.3	16	3.5	1.6	1	109	129	31.7	48.6	0.83
	RB 10020		150	123	20	3.5	1.6	1	113	133	33.1	50.9	1.45
110	RB 11012	110	135	121.8	12	2.5	1	0.6	117	128	12.5	24.1	0.4
	RB 11015		145	126.5	15	3.5	1.6	0.6	119	136	23.7	41.5	0.75
	RB 11020		160	133	20	3.5	1.6	1	120	143	34	54	1.56
120	RB 12016	120	150	134.2	16	3.5	1.6	0.6	127	141	24.2	43.2	0.72
	RB 12025		180	148.7	25	3.5	2	1.5	133	164	66.9	100	2.62
	RB 13015		130	160	144.5	15	3.5	1.6	0.6	137	152	25	46.7
RB 13025	190	158		25	3.5	2	1.5	143	174	69.5	107	2.82	

Note1) The model number of a type with seals attached is RB...UU.

If a certain level of accuracy is required, this model is used for inner ring rotation.

Note2) (a) and (b) dimensions of the lubrication hole in the detailed diagram are reference values.

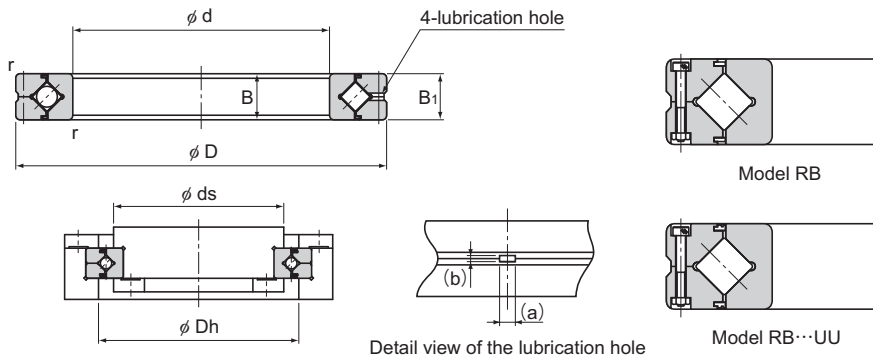

Unit: mm

Shaft diameter	Model No.	Main dimensions							Shoulder height		Basic load rating (radial)		Mass kg
		Inner diameter d	Outer diameter D	Roller pitch circle diameter dp	Width B B ₁	Lubrication hole		r _{min}	ds (max)	Dh (min)	C kN	C ₀ kN	
						a	b						
140	RB 14016	140	175	154.8	16	2.5	1.6	1	147	162	25.9	50.1	1
	RB 14025		200	168	25	3.5	2	1.5	154	185	74.8	121	2.96
150	RB 15013	150	180	164	13	2.5	1.6	0.6	157	172	27	53.5	0.68
	RB 15025		210	178	25	3.5	2	1.5	164	194	76.8	128	3.16
	RB 15030		230	188	30	4.5	3	1.5	169	211	100	156	5.3
160	RB 16025	160	220	188.6	25	3.5	2	1.5	173	204	81.7	135	3.14
170	RB 17020	170	220	191	20	3.5	1.6	1.5	184	198	29	62.1	2.21
180	RB 18025	180	240	210	25	3.5	2	1.5	195	225	84	143	3.44
190	RB 19025	190	240	211.9	25	3.5	1.6	1	202	222	41.7	82.9	2.99
200	RB 20025	200	260	230	25	3.5	2	2	215	245	84.2	157	4
	RB 20030		280	240	30	4.5	3	2	221	258	114	200	6.7
	RB 20035		295	247.7	35	5	3	2	225	270	151	252	9.6
220	RB 22025	220	280	250.1	25	3.5	2	2	235	265	92.3	171	4.1
240	RB 24025	240	300	269	25	3.5	2	2.5	256	281	68.3	145	4.5
250	RB 25025	250	310	277.5	25	3.5	2	2.5	265	290	69.3	150	5
	RB 25030		330	287.5	30	4.5	3	2.5	269	306	126	244	8.1
	RB 25040		355	300.7	40	6	3.5	2.5	275	326	195	348	14.8
300	RB 30025	300	360	328	25	3.5	2	2.5	315	340	76.3	178	5.9
	RB 30035		395	345	35	5	3	2.5	322	368	183	367	13.4
	RB 30040		405	351.6	40	6	3.5	2.5	326	377	212	409	17.2
350	RB 35020	350	400	373.4	20	3.5	1.6	2.5	363	383	54.1	143	3.9

Note1) The model number of a type with seals attached is RB...UU.

If a certain level of accuracy is required, this model is used for inner ring rotation.

Note2) (a) and (b) dimensions of the lubrication hole in the detailed diagram are reference values.

Model number coding

RB3010 UU CC0 P5

Model number

Accuracy symbol (*2)

Radial clearance symbol (*1)

Seal attached on both ends (seal attached on either end: U)

(*1) See **A18-18**. (*2) See **A18-13**.

Model RB (Separable Outer Ring Type)

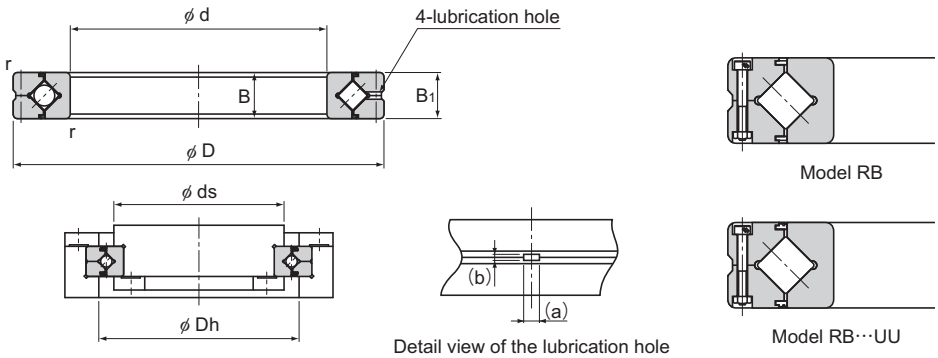

Unit: mm

Shaft diameter	Model No.	Main dimensions							Shoulder height		Basic load rating (radial)		Mass
		Inner diameter	Outer diameter	Roller pitch circle diameter	Width	Lubrication hole		r_{min}	ds (max)	Dh (min)	C	C_0	
						B	B_1						
400	RB 40035	400	480	440.3	35	5	3	2.5	422	459	156	370	14.5
	RB 40040		510	453.4	40	6	3.5	2.5	428	479	241	531	23.5
450	RB 45025	450	500	474	25	3.5	1.6	1	464	484	61.7	182	6.6
500	RB 50025	500	550	524.2	25	3.5	1.6	1	514	534	65.5	201	7.3
	RB 50040		600	548.8	40	6	3	2.5	526	572	239	607	26
	RB 50050		625	561.6	50	6	3.5	2.5	536	587	267	653	41.7
600	RB 60040	600	700	650	40	6	3	3	627	673	264	721	29
700	RB 70045	700	815	753.5	45	6	3	3	731	777	281	836	46
800	RB 80070	800	950	868.1	70	6	4	4	836	900	468	1330	105
900	RB 90070	900	1050	969	70	6	4	4	937	1001	494	1490	120
1000	RB 1000110	1000	1250	1114	110	6	6	5	1057	1171	1220	3220	360
1250	RB 1250110	1250	1500	1365.8	110	6	6	5	1308	1423	1350	3970	440

Note1) The model number of a type with seals attached is RB...UU.

If a certain level of accuracy is required, this model is used for inner ring rotation.

Note2) (a) and (b) dimensions of the lubrication hole in the detailed diagram are reference values.

Model number coding

RB40040 UU C0 PE5

Model number

Accuracy symbol (*2)

Radial clearance symbol (*1)

Seal attached on both ends (seal attached on either end: U)

(*1) See **A18-18** . (*2) See **A18-13**.

Model RE (Two-piece Inner Ring Type)

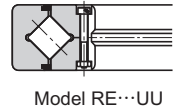
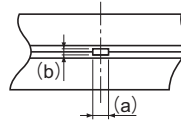
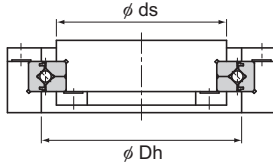
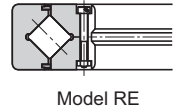
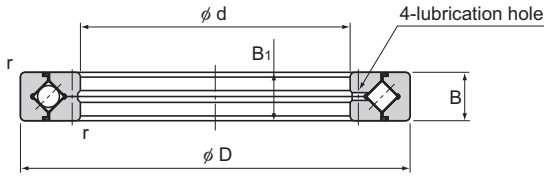

Detail view of the lubrication hole

Unit: mm

Shaft diameter	Model No.	Main dimensions							Shoulder height		Basic load rating (radial)		Mass
		Inner diameter d	Outer diameter D	Roller pitch circle diameter dp	Width B B ₁	Lubrication hole		r _{min}	ds (max)	Dh (min)	C	C ₀	kg
						a	b						
20	RE 2008	20	36	29	8	2	0.8	0.5	24.5	32.5	3.23	3.1	0.04
25	RE 2508	25	41	34	8	2	0.8	0.5	29.5	37.5	3.63	3.83	0.05
30	RE 3010	30	55	43.5	10	2.5	1	0.6	37.5	48.5	7.35	8.36	0.12
35	RE 3510	35	60	48.5	10	2.5	1	0.6	42.5	53.5	7.64	9.12	0.13
40	RE 4010	40	65	53.5	10	2.5	1	0.6	47.5	58.5	8.33	10.6	0.16
45	RE 4510	45	70	58.5	10	2.5	1	0.6	52.5	63.5	8.62	11.3	0.17
50	RE 5013	50	80	66	13	2.5	1.6	0.6	57.5	73	16.7	20.9	0.27
60	RE 6013	60	90	76	13	2.5	1.6	0.6	68	83	18	24.3	0.3
70	RE 7013	70	100	86	13	2.5	1.6	0.6	78	93	19.4	27.7	0.35
80	RE 8016	80	120	101.4	16	3	1.6	0.6	91	111	30.1	42.1	0.7
90	RE 9016	90	130	112	16	3	1.6	1	100	122	31.4	45.3	0.75
100	RE 10016	100	140	121.1	16	3	1.6	1	109	131	31.7	48.6	0.83
	RE 10020		150	127	20	3.5	1.6	1	115	137	33.1	50.9	1.45
110	RE 11012	110	135	123.3	12	2.5	1	0.6	117	128	12.5	24.1	0.4
	RE 11015		145	129	15	3	1.6	0.6	122	136	23.7	41.5	0.75
	RE 11020		160	137	20	3.5	1.6	1	125	147	34	54	1.56
120	RE 12016	120	150	136	16	3	1.6	0.6	127	143	24.2	43.2	0.72
	RE 12025		180	152	25	3.5	2	1.5	135	166	66.9	100	2.62
	RE 13015		160	146	15	3	1.6	0.6	137	153	25	46.7	0.72
130	RE 13025	130	190	162	25	3.5	2	1.5	145	176	69.5	107	2.82

Note1) The model number of a type with seals attached is RE...UU.

If a certain level of accuracy is required, this model is used for outer ring rotation.

Note2) (a) and (b) dimensions of the lubrication hole in the detailed diagram are reference values.

Model RE (Two-piece Inner Ring Type)

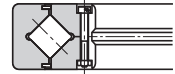
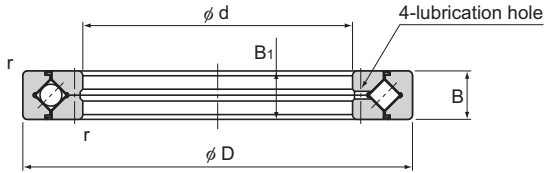

Model RE

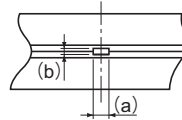
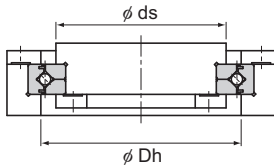

Detail view of the lubrication hole

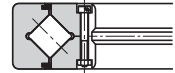

Model RE...UU

Unit: mm

Shaft diameter	Model No.	Main dimensions							Shoulder height		Basic load rating (radial)		Mass kg
		Inner diameter d	Outer diameter D	Roller pitch circle diameter dp	Width B B ₁	Lubrication hole		r_{min}	ds (max)	Dh (min)	C kN	C ₀ kN	
						a	b						
140	RE 14016	140	175	156.8	16	3	1.6	1	151	167	25.9	50.1	1
	RE 14025		200	172	25	3.5	2	1.5	154	186	74.8	121	2.96
150	RE 15013	150	180	166	13	2.5	1.6	0.6	158	173	27	53.5	0.68
	RE 15025		210	182	25	3.5	2	1.5	164	196	76.8	128	3.16
	RE 15030		230	192	30	4.5	3	1.5	173	210	100	156	5.3
160	RE 16025	160	220	192	25	3.5	2	1.5	174	206	81.7	135	3.14
170	RE 17020	170	220	196.1	20	3.5	1.6	1.5	187	204	29	62.1	2.21
180	RE 18025	180	240	210	25	3.5	2	1.5	195	225	84	143	3.44
190	RE 19025	190	240	219	25	3.5	1.6	1	207	229	41.7	82.9	2.99
200	RE 20025	200	260	230	25	3.5	2	2	215	245	84.2	157	4
	RE 20030		280	240	30	4.5	3	2	221	258	114	200	6.7
	RE 20035		295	247.7	35	5	3	2	225	270	151	252	9.6
220	RE 22025	220	280	250.1	25	3.5	2	2	235	265	92.3	171	4.1
240	RE 24025	240	300	272.5	25	3.5	2	2.5	258	284	68.3	145	4.5
250	RE 25025	250	310	280.9	25	3.5	2	2.5	268	293	69.3	150	5
	RE 25030		330	287.5	30	4.5	3	2.5	269	306	126	244	8.1
	RE 25040		355	300.7	40	6	3.5	2.5	275	326	195	348	14.8
300	RE 30025	300	360	332	25	3.5	2	2.5	319	344	75.5	178	5.9
	RE 30035		395	345	35	5	3	2.5	322	368	183	367	13.4
	RE 30040		405	351.6	40	6	3.5	2.5	326	377	212	409	17.2
350	RE 35020	350	400	376.6	20	3.5	1.6	2.5	365	386	54.1	143	3.9

Note1) The model number of a type with seals attached is RE...UU.

If a certain level of accuracy is required, this model is used for outer ring rotation.

Note2) (a) and (b) dimensions of the lubrication hole in the detailed diagram are reference values.

Model number coding

RE8016 UU CC0 P4

Model number

Accuracy symbol (*2)

Radial clearance symbol (*1)

Seal attached on both ends (seal attached on either end: U)

(*1) See **A18-18**. (*2) See **A18-13**.

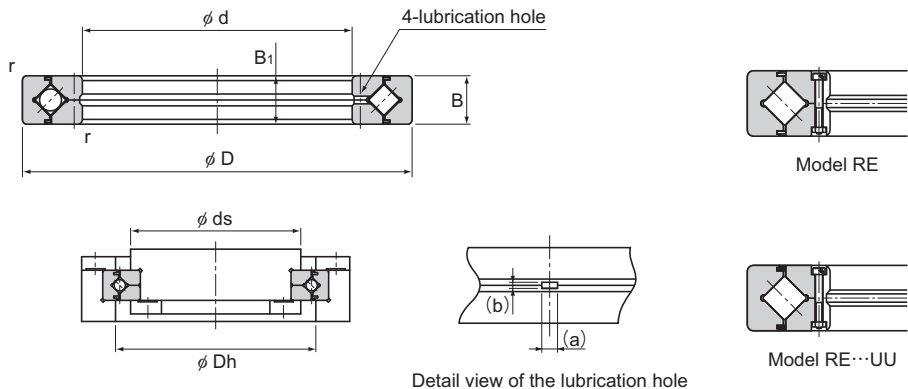

Detail view of the lubrication hole

Unit: mm

Shaft diameter	Model No.	Main dimensions							Shoulder height		Basic load rating (radial)		Mass
		Inner diameter	Outer diameter	Roller pitch circle diameter	Width	Lubrication hole		r_{\min}	ds (max)	Dh (min)	C	C_0	
						a	b						
400	RE 40035	400	480	440.3	35	5	3	2.5	422	459	156	370	14.5
	RE 40040		510	453.4	40	6	3.5	2.5	428	479	241	531	23.5
450	RE 45025	450	500	476.6	25	3.5	1.6	1	465	486	61.7	182	6.6
	RE 50025		550	526.6	25	3.5	1.6	1	515	536	65.5	201	7.3
500	RE 50040	500	600	548.8	40	6	3	2.5	526	572	239	607	26
	RE 50050		625	561.6	50	6	3.5	2.5	536	587	267	653	41.7
600	RE 60040	600	700	650	40	6	3	3	627	673	264	721	29

Note1) The model number of a type with seals attached is RE...UU.

If a certain level of accuracy is required, this model is used for outer ring rotation.

Note2) (a) and (b) dimensions of the lubrication hole in the detailed diagram are reference values.

Model number coding

RE50025 UU CC0 P6

Model number

Accuracy symbol (*2)

Radial clearance symbol (*1)

Seal attached on both ends (seal attached on either end: U)

(*1) See **A18-18**. (*2) See **A18-13**.

USP-Grade Models RB and RE

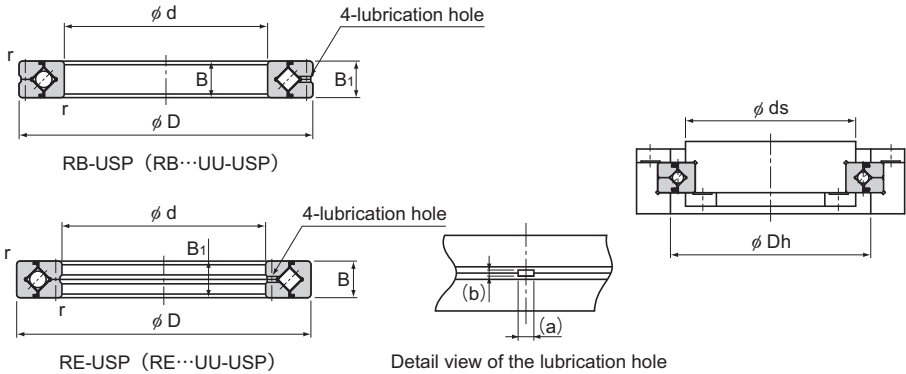

Unit: mm

Model No.	Main dimensions							Shoulder height		Basic load rating (radial)		Mass	
	Inner diameter	Outer diameter	Roller pitch circle diameter dp		Width	Lubrication hole		r _{min}	ds (max)	Dh (min)	C		C ₀
			RB	RE		B B ₁	a					b	
RB 10020USP RE 10020USP	100	150	123	127	20	3.5	1.6	1	113	133	33.1	50.9	1.45
RB 12025USP RE 12025USP	120	180	148.7	152	25	3.5	2	1.5	133	164	66.9	100	2.62
RB 15025USP RE 15025USP	150	210	178	182	25				164	194	76.8	128	3.16
RB 20030USP RE 20030USP	200	280	240	240	30	4.5	3	2	221	258	114	200	6.7
RB 25030USP RE 25030USP	250	330	287.5	287.5	30				269	306	126	244	8.1
RB 30035USP RE 30035USP	300	395	345	345	35	5	3	2.5	322	368	183	367	13.4
RB 40040USP RE 40040USP	400	510	453.4	453.4	40				428	479	241	531	23.5
RB 50040USP RE 50040USP	500	600	548.8	548.8	40	6	3	2.5	526	572	239	607	26
RB 60040USP RE 60040USP	600	700	650	650	40				627	673	264	721	29

Note1) The model number of a type with seals attached is RB...UU-USP or RE...UU-USP.

If a certain level of rotational accuracy is required for the inner ring, select model RB; if a certain level of rotational accuracy is required for the outer ring, select model RE.

Note2) (a) and (b) dimensions of the lubrication hole in the detailed diagram are reference values.

Model number coding

RB50040 UU CC0 USP

Model number

Accuracy symbol (Ultra precision grade)

Radial clearance symbol (*1)

Seal attached on both ends (seal attached on either end: U)

(*1) See **A18-18**.

Model RAU (Small-Diameter, 5 mm Thin Type)

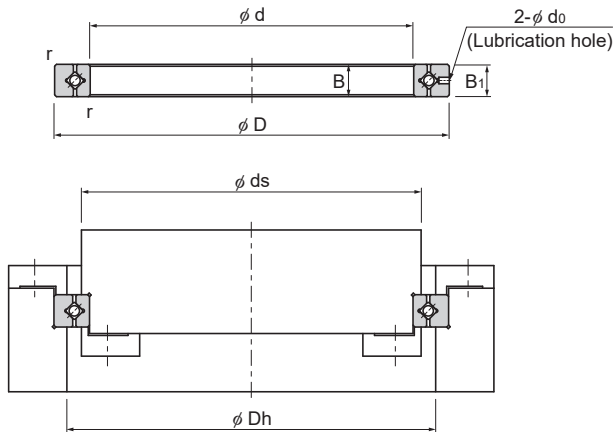

Unit: mm

Shaft diameter	Model No.	Main dimensions						Shoulder height		Basic load rating (radial)		Mass
		Inner diameter d	Outer diameter D	Roller pitch circle diameter dp	Width B B ₁	Lubrication hole d _o	r _{min}	ds (max)	Dh (min)	C kN	C ₀ kN	
10	RAU 1005	10	21	14.7	5	1	0.15	12.5	17	1.12	0.809	9
15	RAU 1505	15	26	19.7	5	1	0.15	17.5	22	1.32	1.1	12
20	RAU 2005	20	31	24.7	5	1	0.15	22.5	27	1.49	1.4	15
30	RAU 3005	30	41	34.7	5	1	0.15	32.5	37	1.89	2.14	21
40	RAU 4005	40	51	44.7	5	1	0.15	42.5	47	2.14	2.74	27
50	RAU 5005	50	61	54.7	5	1	0.15	52.5	57	2.43	3.49	32
60	RAU 6005	60	71	64.7	5	1	0.15	62.5	67	2.63	4.09	38
70	RAU 7005	70	81	74.7	5	1	0.15	72.5	77	2.81	4.68	44
80	RAU 8005	80	91	84.7	5	1	0.15	82.5	87	3.05	5.43	50
90	RAU 9005	90	101	94.7	5	1	0.15	92.5	97	3.19	6.03	56
100	RAU 10005	100	111	104.7	5	1	0.15	102.5	107	3.37	6.63	61

Model number coding

RAU5005 C0 P4 B

Model number | Accuracy symbol (*2) | Radial clearance symbol (*1) | Component accuracy symbol

(*1)See **A18-18**. (*2)See **A18-14**.

Note) Precautions for the Model RAU (Small-Diameter, 5 mm Thin Type)

* Seals are not supported. * Only available with C0 radial clearance. * Only available with normal grade accuracy (0).

Model RAU (Model RA Interchangeable Type)

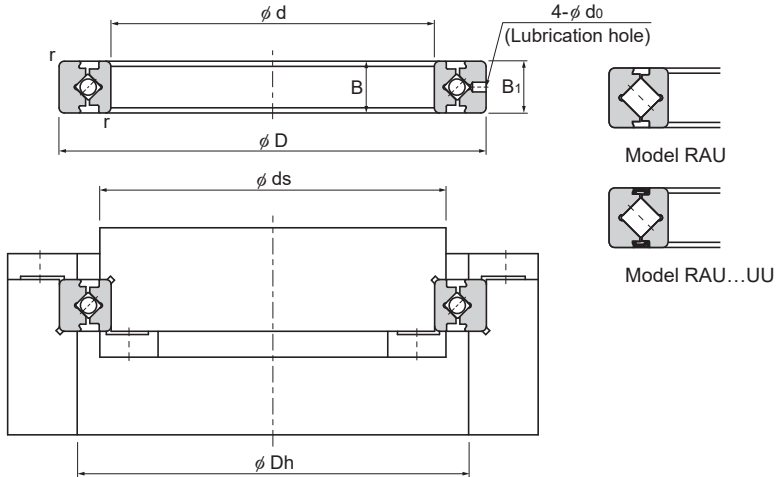

Unit: mm

Shaft diameter	Model No.	Main dimensions						Shoulder height		Basic load rating (radial)		Mass
		Inner diameter	Outer diameter	Roller pitch circle diameter	Width	Lubrication hole			C	C ₀	kg	
		d	D	dp	B B ₁	d ₀	r _{min}	ds (max)	Dh (min)	kN	kN	kg
50	RAU 5008	50	66	57	8	1.5	0.5	53.5	60.5	5.10	7.19	0.08
60	RAU 6008	60	76	67	8	1.5	0.5	63.5	70.5	5.68	8.68	0.09
70	RAU 7008	70	86	77	8	1.5	0.5	73.5	80.5	5.98	9.80	0.1
80	RAU 8008	80	96	87	8	1.5	0.5	83.5	90.5	6.37	11.3	0.11
90	RAU 9008	90	106	97	8	1.5	0.5	93.5	100.5	6.76	12.4	0.12
100	RAU 10008	100	116	107	8	1.5	0.5	103.5	110.5	7.15	13.9	0.14
110	RAU 11008	110	126	117	8	1.5	0.5	113.5	120.5	7.45	15	0.15
120	RAU 12008	120	136	127	8	1.5	0.5	123.5	130.5	7.84	16.5	0.17
130	RAU 13008	130	146	137	8	1.5	0.5	133.5	140.5	7.94	17.6	0.18
140	RAU 14008	140	156	147	8	1.5	0.5	143.5	150.5	8.33	19.1	0.19
150	RAU 15008	150	166	157	8	1.5	0.5	153.5	160.5	8.82	20.6	0.2
160	RAU 16013	160	186	172	13	2	0.8	165	179	23.3	44.9	0.59
170	RAU 17013	170	196	182	13	2	0.8	175	189	23.5	46.5	0.64
180	RAU 18013	180	206	192	13	2	0.8	185	199	24.5	49.8	0.68
190	RAU 19013	190	216	202	13	2	0.8	195	209	24.9	51.5	0.69
200	RAU 20013	200	226	212	13	2	0.8	205	219	25.8	54.7	0.71

Model number coding

RAU5008 UU CC0 P4 B

Model number

Radial clearance symbol (*1)

Accuracy symbol (*2)

Component accuracy symbol

Seal attached on both ends (seal attached on either end: U)

(*1)See **A18-18**. (*2)See **A18-14**.

Model RA (Separable Outer Ring Type)

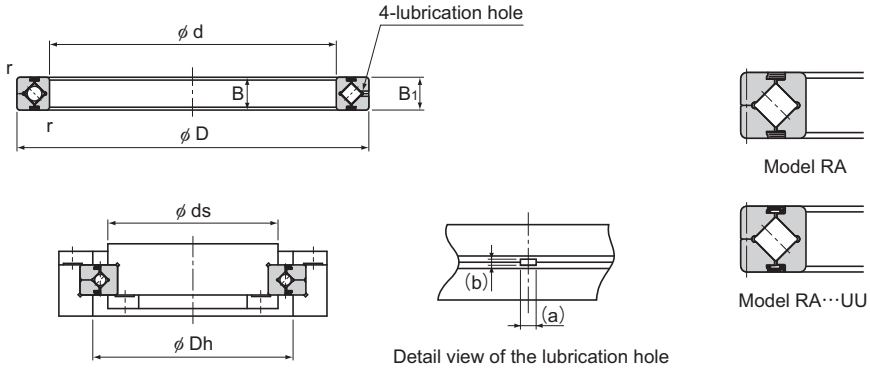

Unit: mm

Shaft diameter	Model No.	Main dimensions							Shoulder height		Basic load rating (radial)		Mass
		Inner diameter	Outer diameter	Roller pitch circle diameter	Width	Lubrication hole		r_{min}	ds (max)	Dh (min)	C	C_0	
						B	B_1						
50	RA 5008	50	66	57	8	2	0.8	0.5	53.5	60.5	5.10	7.19	0.08
60	RA 6008	60	76	67	8	2	0.8	0.5	63.5	70.5	5.68	8.68	0.09
70	RA 7008	70	86	77	8	2	0.8	0.5	73.5	80.5	5.98	9.80	0.1
80	RA 8008	80	96	87	8	2	0.8	0.5	83.5	90.5	6.37	11.3	0.11
90	RA 9008	90	106	97	8	2	0.8	0.5	93.5	100.5	6.76	12.4	0.12
100	RA 10008	100	116	107	8	2	0.8	0.5	103.5	110.5	7.15	13.9	0.14
110	RA 11008	110	126	117	8	2	0.8	0.5	113.5	120.5	7.45	15	0.15
120	RA 12008	120	136	127	8	2	0.8	0.5	123.5	130.5	7.84	16.5	0.17
130	RA 13008	130	146	137	8	2	0.8	0.5	133.5	140.5	7.94	17.6	0.18
140	RA 14008	140	156	147	8	2	0.8	0.5	143.5	150.5	8.33	19.1	0.19
150	RA 15008	150	166	157	8	2	0.8	0.5	153.5	160.5	8.82	20.6	0.2
160	RA 16013	160	186	172	13	2.5	1.6	0.8	165	179	23.3	44.9	0.59
170	RA 17013	170	196	182	13	2.5	1.6	0.8	175	189	23.5	46.5	0.64
180	RA 18013	180	206	192	13	2.5	1.6	0.8	185	199	24.5	49.8	0.68
190	RA 19013	190	216	202	13	2.5	1.6	0.8	195	209	24.9	51.5	0.69
200	RA 20013	200	226	212	13	2.5	1.6	0.8	205	219	25.8	54.7	0.71

Note1) The model number of a type with seals attached is RA...UU.

If a certain level of accuracy is required, this model is used for inner ring rotation.

Note2) (a) and (b) dimensions of the lubrication hole in the detailed diagram are reference values.

Model number coding

RA7008 UU CC0

Model number

Radial clearance symbol (*1)

Seal attached on both ends (seal attached on either end: U)

(*1) See **A18-18**.

Model RA-C (Single-Split Type)

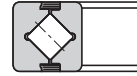
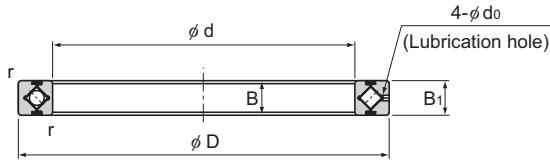

Model RA...C

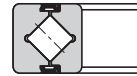

Model RA...CUU

Unit: mm

Shaft diameter	Model No.	Main dimensions						Shoulder height		Basic load rating (radial)		Mass
		Inner diameter d	Outer diameter D	Roller pitch circle diameter dp	Width B B ₁	Lubrication hole d _o	r _{min}	ds (max)	Dh (min)	C kN	C ₀ kN	
50	RA 5008C	50	66	57	8	1.5	0.5	53.5	60.5	5.1	7.19	0.08
60	RA 6008C	60	76	67	8	1.5	0.5	63.5	70.5	5.68	8.68	0.09
70	RA 7008C	70	86	77	8	1.5	0.5	73.5	80.5	5.98	9.8	0.1
80	RA 8008C	80	96	87	8	1.5	0.5	83.5	90.5	6.37	11.3	0.11
90	RA 9008C	90	106	97	8	1.5	0.5	93.5	100.5	6.76	12.4	0.12
100	RA 10008C	100	116	107	8	1.5	0.5	103.5	110.5	7.15	13.9	0.14
110	RA 11008C	110	126	117	8	1.5	0.5	113.5	120.5	7.45	15	0.15
120	RA 12008C	120	136	127	8	1.5	0.5	123.5	130.5	7.84	16.5	0.17
130	RA 13008C	130	146	137	8	1.5	0.5	133.5	140.5	7.94	17.6	0.18
140	RA 14008C	140	156	147	8	1.5	0.5	143.5	150.5	8.33	19.1	0.19
150	RA 15008C	150	166	157	8	1.5	0.5	153.5	160.5	8.82	20.6	0.2
160	RA 16013C	160	186	172	13	2	0.8	165	179	23.3	44.9	0.59
170	RA 17013C	170	196	182	13	2	0.8	175	189	23.5	46.5	0.64
180	RA 18013C	180	206	192	13	2	0.8	185	199	24.5	49.8	0.68
190	RA 19013C	190	216	202	13	2	0.8	195	209	24.9	51.5	0.69
200	RA 20013C	200	226	212	13	2	0.8	205	219	25.8	54.7	0.71

Note) The model number of a type with seals attached is RA...CUU.

If a certain level of accuracy is required, this model is used for inner ring rotation.

Model number coding

RA6008C UU C0

Model number

Radial clearance symbol (*1)

Seal attached on both ends (seal attached on either end: U)

(*1) See **A18-18**.