

Features of the Link Ball

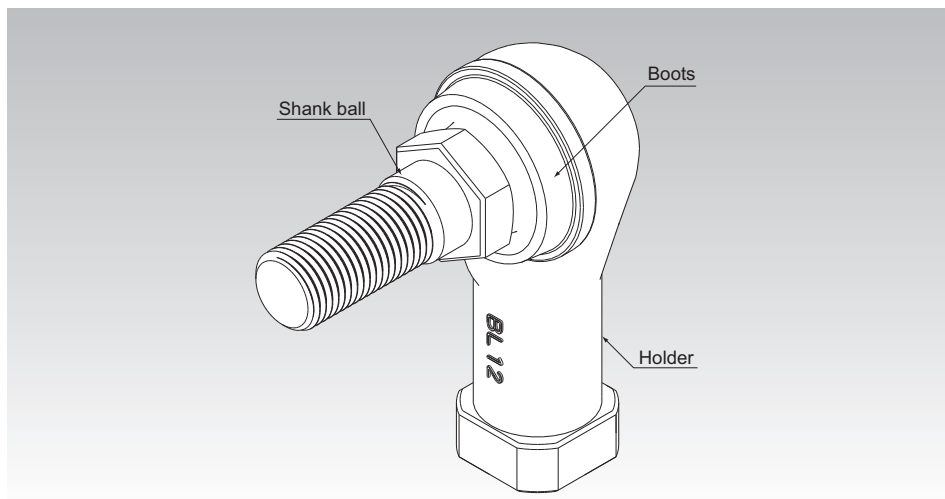

Fig.1 Structure of Link Ball Model BL

Structure and Features

With the Link Ball, a highly accurate bearing steel ball used in the spherical area is first encased in the holder by die cast molding, and then is specially welded with the shank. This unique process enables the mirror surface of the steel ball to be transferred or duplicated on the spherical surface inside the holder to ensure full contact between the ball and the holder. As a result, smooth motion is achieved with a minimum clearance.

Features and Types

Features of the Link Ball

[Compact Design]

Model BL has an adequately firm and yet extremely compact shape because of a highly balanced design. This model is optimal for use in an automobile height sensor or transmission control.

[Achieves Sphericity of 0.001 mm]

The spherical surface of the shank ball is transferred on the inner surface of the holder while maintaining the sphericity of the bearing steel ball. This allows smooth motion to be achieved with a minimum clearance and provides favorable operability and feel to the link motion.

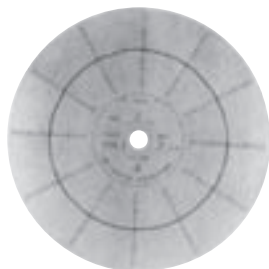

Sphericity: 0.001 mm

Sphericity of the spherical surface of the ball shank

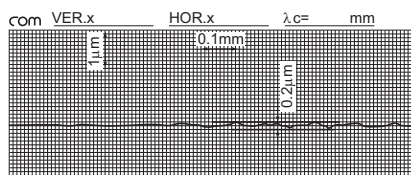

Roughness of the spherical surface of the ball shank

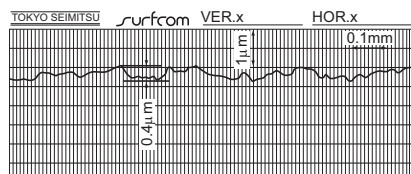

Roughness of the spherical surface of the holder

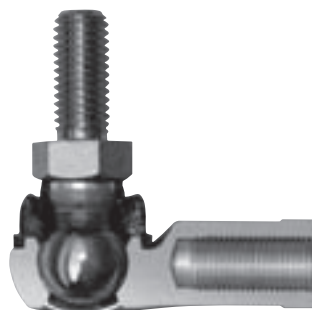
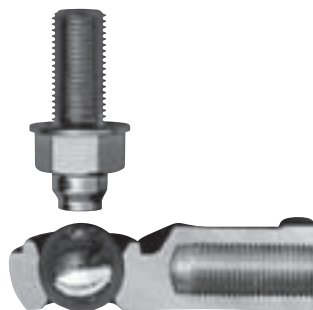

Cut sample of the spherical area of model BL

[Two Types of Holder Material]

Model BL-A uses the newly developed high strength aluminum alloy "A-1 Alloy" (see **A22-5**), which is light and highly resistant to wear.

Models BL6 and above and model RBI uses the proven high strength zinc alloy (see **A22-6**).

[High Lubricity]

The boot contains grease for high lubricity and increased wear resistance.

[Large Hexagonal Bolt Seat]

The hexagonal bolt seat of the shank has the same dimensions as the seating surface for small hexagon head bolts in accordance with automotive specifications. This prevents the seating surface from sinking and ensures a stable link motion mechanism.

[Equipped with a Boot for Protection against Muddy Water]

Use of a boot with high trackability in the ball shank prevents muddy water from entering the spherical area even in a muddy atmosphere. Accordingly, those types equipped with boots are used also in outdoor applications and automobile parts under the chassis. For details, see the muddy water test data (**B22-8** and **B22-9**).

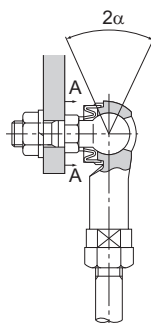

Model BL10



Model equivalent to similar product

A-A cross section

Jaw Span for Wrenching

Alloy

[High Strength Aluminum Alloy “A-1 Alloy”]

“A-1 Alloy,” a newly developed high strength aluminum alloy, is an alloy with Al-Zn-Si₃ being the main components, is used in the holder of model BL-A. Information on the mechanical properties, physical properties, and wear resistance of materials is presented below.

* The figures shown are target values—these figures are not guaranteed.

● Features of the A-1 Alloy

- Achieves one of the highest strengths among the existing aluminum die cast alloys.
- Has yield strength approximately twice that of the commonly used aluminum die cast alloy (ADC 12).
- Has hardness equal to the high strength zinc alloy and achieves high wear resistance.
- Achieves specific gravity less than a half of the high strength zinc alloy to allow significant weight saving.
- Highly corrosion resistance and can be used as an automotive part related to wheel control.

● Mechanical Properties

Tensile strength	: 343 to 392 N/mm ²
Tensile yield strength (0.2%)	: 245 to 294 N/mm ²
Compressive strength	: 490 to 637 N/mm ²
Compressive yield strength (0.2%)	: 294 to 343 N/mm ²
Charpy impact	: 0.098 to 0.196 N·m/mm ²
Elongation	: 2 to 3 %
Hardness	: 140 to 160 HV

● Physical Properties

Specific gravity	: 3
Melting point	: 570°C
Specific heat	: 793 J/(kg·k)
Linear expansion rate	: 22×10^{-6}

[High Strength Zinc Alloy]

The high strength zinc alloy used in the holders of models BL and RBI has been developed as a bearing alloy by mixing Al, Cu, Mg, Be and Ti as well as zinc as the base component. It is excellent in mechanical properties, seizure resistance and wear resistance. Information on mechanical properties, physical properties, and wear resistance is presented below.

* The figures shown are target values—these figures are not guaranteed.

● Mechanical Properties

Tensile strength	: 275 to 314 N/mm ²
Tensile yield strength (0.2%)	: 216 to 245 N/mm ²
Compressive strength	: 539 to 686 N/mm ²
Compressive yield strength (0.2%)	: 294 to 343 N/mm ²
Fatigue strength	: 132 N/mm ² × 10 ⁷ (Schenk bending test)
Charpy impact	: 0.098 to 0.49 N·m/mm ²
Elongation	: 1 to 5%
Hardness	: 120 to 145 HV

● Physical Properties

Specific gravity	: 6.8
Melting point	: 390°C
Specific heat	: 460 J/(kg·k)
Linear expansion rate	: 24 × 10 ⁻⁶

● Wear Resistance

The wear resistance of the high strength zinc alloy is superior to that of class-3 brass and class-3 bronze, almost equal to that of class-2 phosphor bronze.

Amsler wear-tester

Test piece rotation speed	: 185 min ⁻¹
Load	: 392 N
Lubricant	: Dynamo oil

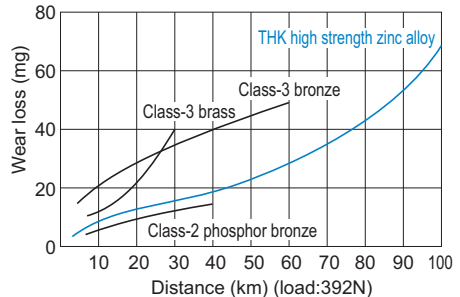

Fig.2 Wear Resistance of the High Strength Zinc Alloy

How Load Directions Are Called

Regardless of the shape, the direction of the load applied to the Link Ball is called “axial direction” if it is parallel to the axis of the ball shank, and “radial direction” if it is perpendicular to the axis.

Pushing Load and Pulling Load

Of the loads applied in the axial direction, the load in the direction of the ball shank being pressed toward the holder is called “pushing load” and the load in the direction of the ball shank being pulled from the holder is called “pulling load.”

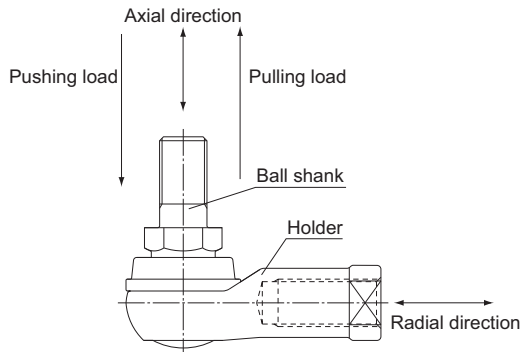

● Direction of applied load

The following table shows the load application direction of each model. Avoid using the product in a different load application direction. Failure to do so may damage the product.

Model No.	Axial direction	Radial direction
Model BL	×	○
Model BL-A	×	○
Model RBI	○	×