

Models SHS-C, SHS-CM, SHS-LC and SHS-LCM

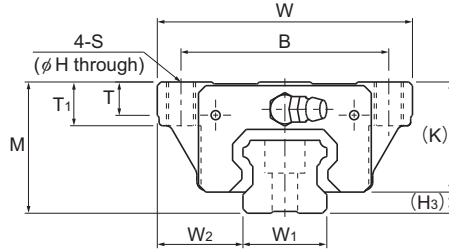

Model No.	Outer dimensions			LM block dimensions											Pilot hole for side nipple			
	Height	Width	Length												Grease nipple			
	M	W	L	B	C	S	H	L ₁	T	T ₁	K	N	E		e ₀	f ₀	D ₀	
SHS 15C SHS 15CM	24	47	64.4	38	30	M5	4.4	48	5.9	8	21	5.5	5.5	PB1021B	4	4	3	
SHS 15LC SHS 15LCM	24	47	79.4	38	30	M5	4.4	63	5.9	8	21	5.5	5.5	PB1021B	4	4	3	
SHS 20C SHS 20CM	30	63	79	53	40	M6	5.4	59	7.2	10	25.4	6.5	12	B-M6F	4.3	5.3	3	
SHS 20LC SHS 20LCM	30	63	98	53	40	M6	5.4	78	7.2	10	25.4	6.5	12	B-M6F	4.3	5.3	3	
SHS 25C SHS 25CM	36	70	92	57	45	M8	6.8	71	9.1	12	30.2	7.5	12	B-M6F	4.5	5.5	3	
SHS 25LC SHS 25LCM	36	70	109	57	45	M8	6.8	88	9.1	12	30.2	7.5	12	B-M6F	4.5	5.5	3	
SHS 30C SHS 30LC	42	90	106 131	72	52	M10	8.5	80 105	11.5	15	35	8	12	B-M6F	5.8	6	5.2	
SHS 35C SHS 35LC	48	100	122 152	82	62	M10	8.5	93 123	11.5	15	40.5	8	12	B-M6F	6.5	5.5	5.2	
SHS 45C SHS 45LC	60	120	140 174	100	80	M12	10.5	106 140	14.1	18	51.1	10.5	16	B-PT1/8	8	8	5.2	
SHS 55C SHS 55LC	70	140	171 213	116	95	M14	12.5	131 173	16	21	57.3	11	16	B-PT1/8	10	8	5.2	
SHS 65C SHS 65LC	90	170	221 272	142	110	M16	14.5	175 226	18.8	24	71	19	16	B-PT1/8	10	12	5.2	

Model number coding

SHS25 LC 2 QZ KKHH C0 M +1240L P Z T M - II

Model number

Type of LM block

With QZ Lubricator

Contamination protection accessory symbol (*1)

Stainless steel LM block

LM rail length (in mm)

With steel tape

Stainless steel LM rail

No. of LM blocks used on the same rail

Radial clearance symbol (*2)
Normal (No symbol)
Light preload (C1)
Medium preload (C0)

Accuracy symbol (*3)
Normal grade (No Symbol)
High accuracy grade (H)
Precision grade (P)
Super precision grade (SP)
Ultra precision grade (UP)

Symbol for LM rail jointed use
Symbol for No. of rails used on the same plane (*4)

(*1) See contamination protection accessory on **A1-516**. (*2) See **A1-71**. (*3) See **A1-77**. (*4) See **A1-13**.

(Note) This model number indicates that a single-rail unit constitutes one set. (i.e., required number of sets when 2 rails are used in parallel is 2 at a minimum.)

Those models equipped with QZ Lubricator cannot have a grease nipple. When desiring a grease nipple for a model attached with QZ, contact THK.

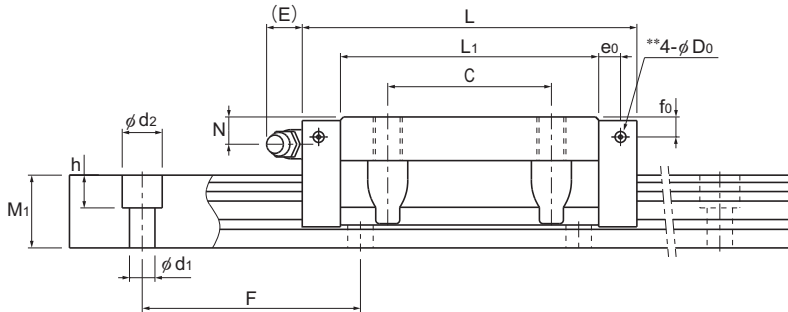

Unit: mm

H ₃	LM rail dimensions						Basic load rating		Static permissible moment kN·m*					Mass	
	W ₁ 0 -0.05	Width	Height	Pitch	d ₁ × d ₂ × h	Length*	C	C ₀	M _A		M _B		M _C	LM block kg	LM rail kg/m
		W ₂	M ₁	F		Max			1 block	Double blocks	1 block	Double blocks	1 block		
3	15	16	13	60	4.5 × 7.5 × 5.3	3000 (1240)	14.2	24.2	0.175	0.898	0.175	0.898	0.16	0.23	1.3
3	15	16	13	60	4.5 × 7.5 × 5.3	3000 (1240)	17.2	31.9	0.296	1.43	0.296	1.43	0.212	0.29	1.3
4.6	20	21.5	16.5	60	6 × 9.5 × 8.5	3000 (1480)	22.3	38.4	0.334	1.75	0.334	1.75	0.361	0.46	2.3
4.6	20	21.5	16.5	60	6 × 9.5 × 8.5	3000 (1480)	28.1	50.3	0.568	2.8	0.568	2.8	0.473	0.61	2.3
5.8	23	23.5	20	60	7 × 11 × 9	3000 (2020)	31.7	52.4	0.566	2.75	0.566	2.75	0.563	0.72	3.2
5.8	23	23.5	20	60	7 × 11 × 9	3000 (2020)	36.8	64.7	0.848	3.98	0.848	3.98	0.696	0.89	3.2
7	28	31	23	80	9 × 14 × 12	3000	44.8 54.2	66.6 88.8	0.786 1.36	4.08 6.6	0.786 1.36	4.08 6.6	0.865 1.15	1.34 1.66	4.5
7.5	34	33	26	80	9 × 14 × 12	3000	62.3 72.9	96.6 127	1.38 2.34	6.76 10.9	1.38 2.34	6.76 10.9	1.53 2.01	1.9 2.54	6.2
8.9	45	37.5	32	105	14 × 20 × 17	3090	82.8 100	126 166	2.05 3.46	10.1 16.3	2.05 3.46	10.1 16.3	2.68 3.53	3.24 4.19	10.4
12.7	53	43.5	38	120	16 × 23 × 20	3060	128 161	197 259	3.96 6.68	19.3 31.1	3.96 6.68	19.3 31.1	4.9 6.44	5.35 6.97	14.5
19	63	53.5	53	150	18 × 26 × 22	3000	205 253	320 408	8.26 13.3	40.4 62.6	8.26 13.3	40.4 62.6	9.4 11.9	10.7 13.7	23.7

Note) The maximum length under "Length*" indicates the standard maximum length of an LM rail. (See **A1-102**.)
 Static permissible moment* 1 block: the static permissible moment with one LM block

Double blocks: static permissible moment when two LM blocks are in close contact with each other
 Total block length L : The total block length L shown in the table is the length with the dust proof parts, code UU or SS.
 If other contamination protection accessories or lubricant equipment are installed, the total block length will increase.
 (See **A1-491** or **A1-512**)

** A pilot hole for side nipples, when a grease nipple for a model equipped with LaCS or QZ Lubricator is needed.
 Pilot holes for side nipples are not drilled through for models other than those stated above.
 For grease nipple mount machining, contact THK.