

Models SSR-XV and SSR-XVM

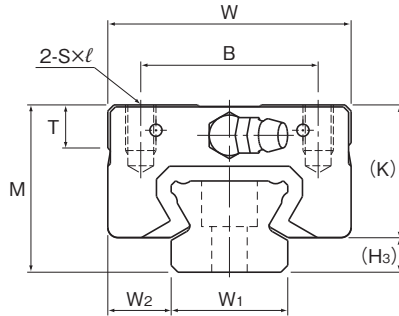

Model No.	Outer dimensions			LM block dimensions											Grease nipple	H ₃
	Height	Width	Length	B	S×ℓ	L ₁	T	K	N	E	f ₀	e ₀	D ₀			
	M	W	L													
SSR 15XV SSR 15XVM	24	34	40.3	26	M4×7	23.3	6.5	19.5	4.5	5.5	2.7	4.5	3	PB1021B	4.5	
SSR 20XV SSR 20XVM	28	42	47.7	32	M5×8	27.8	8.2	22	5.5	12	2.9	5.2	3	B-M6F	6	
SSR 25XV SSR 25XVM	33	48	60	35	M6×9	36.8	8.4	26.2	6	12	3.3	6.8	3	B-M6F	6.8	
SSR 30XV SSR 30XVM	42	60	66.7	40	M8×12	40.4	11.5	32.5	8	12	4.5	7.6	4	B-M6F	9.5	
SSR 35XV	48	70	77.5	50	M8×12	47.1	16.2	36.5	8.5	12	4.7	8.8	4	B-M6F	11.5	

Note) The M in the model number symbol indicates that the LM block, LM rail and balls are made of stainless steel. The stainless steel provides excellent corrosion and environmental resistance.

Model number coding

Model number	Type of LM block	With QZ lubricator	Contamination protection accessory symbol (*1)	Stainless steel LM block	LM rail length (in mm)	Accuracy symbol (*3)	Stainless steel LM rail	Symbol for No. of rails used on the same plane (*4)
SSR25X	V	2	QZ	UU	C1	M	+1200L	Y P T M -III
	No. of LM blocks used on the same rail		Radial clearance symbol (*2) Normal (No symbol) Light preload (C1)		Applied to only 15 and 25	Normal grade (No Symbol) High accuracy grade (H)/Precision grade (P) Super precision grade (SP)/Ultra precision grade (UP)	Symbol for LM rail jointed use	

(*1) See contamination protection accessory on **A1-532**. (*2) See **A1-72**. (*3) See **A1-78**. (*4) See **A1-13**.

Note) This model number indicates that a single-rail unit constitutes one set. (i.e., required number of sets when 3 rails are used in parallel is 3 at a minimum.)

Those models equipped with QZ Lubricator cannot have a grease nipple. When desiring a grease nipple for a model attached with QZ, contact THK.

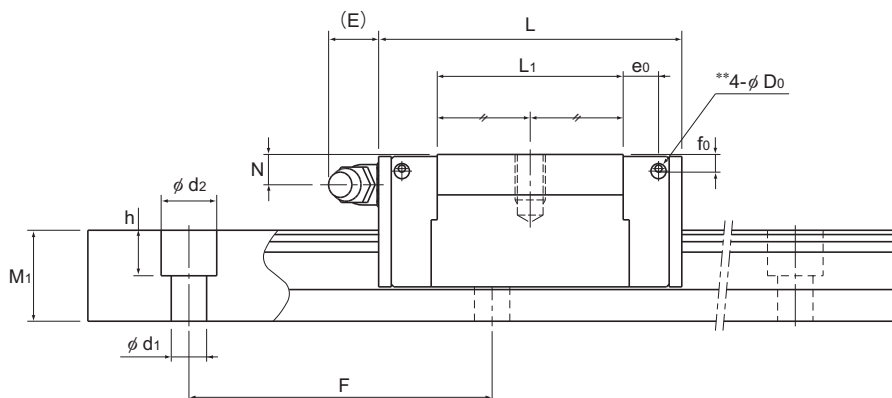

Unit: mm

LM rail dimensions						Basic load rating		Static permissible moment $kN \cdot m^*$					Mass	
Width	Height	Pitch		Length*	C	C ₀	M _A		M _B		M _C	LM block	LM rail	
W ₁ ±0.05	W ₂	M ₁	F	d ₁ × d ₂ × h	Max	kN	kN	1 block	Double blocks	1 block	Double blocks	1 block	kg	kg/m
15	9.5	12.5	60	4.5 × 7.5 × 5.3	3000 (1240)	9.1	9.7	0.0303	0.119	0.0189	0.122	0.0562	0.08	1.2
20	11	15.5	60	6 × 9.5 × 8.5	3000 (1480)	13.4	14.4	0.0523	0.336	0.0326	0.213	0.111	0.14	2.1
23	12.5	18	60	7 × 11 × 9	3000 (2020)	21.7	22.5	0.104	0.661	0.0652	0.419	0.204	0.23	2.7
28	16	23	80	7 × 11 × 9	3000 (2020)	34.8	34.4	0.186	1.12	0.116	0.711	0.376	0.43	4.3
34	18	27.5	80	9 × 14 × 12	3000	48.3	46.7	0.295	1.77	0.184	1.12	0.615	0.6	6.4

Note1) The maximum length under "Length*" indicates the standard maximum length of an LM rail. (See **A1-118**.)
Static permissible moment* 1 block: the static permissible moment with one LM block

Double blocks: static permissible moment when two LM blocks are in close contact with each other
Total block length L : The total block length L shown in the table is the length with the dust proof parts, code UU or SS.
If other contamination protection accessories or lubricant equipment are installed, the total block length will increase.
(See **A1-507** or **A1-528**)

** A pilot hole for side nipples, when a grease nipple for a model equipped with LaCS or QZ Lubricator is needed.

Pilot holes for side nipples are not drilled through for models other than those stated above.

For grease nipple mount machining, contact THK.

Note2) For models SSR15 and 25, two types of rails with different mounting hole dimensions are offered (see Table1).

When, replacing this model with model SR, pay attention to the mounting hole dimension of the LM rail.

Contact THK for details.

Note3) The basic load rating in the dimension table is for a load in the radial direction. Use Table7 on **A1-60** to calculate the load rating for loads in the reverse radial direction or lateral direction.

Table1 The dimension of the rail mounting hole

Model No.	Standard rail	Semi-Standard rail
SSR 15	For M4 (Symbol Y)	For M3 (No symbol)
SSR 25	For M6 (Symbol Y)	For M5 (No symbol)