

Models HR, HR-T, HR-M and HR-TM

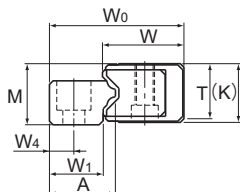

Model No.	Outer dimensions				LM block dimensions									
	Height	Width		Length									Greasing hole	
	M	W	W ₀	L	B ₁	C	H	S	h ₂	L ₁	T	K	d	D ₁
HR 3065 HR 3065T	30	40.3	65	145 173.5	19	50 80	8.6	M10	9	90 118.5	27.5	29	4	14
HR 3575 HR 3575T	35	44.9	75	154.8 182.5	21.5	60 92.5	10.5	M12	12	103.8 131.5	32	34	4	18
HR 4085 HR 4085T	40	50.4	85	177.8 215.9	24	70 110	12.5	M14	13	120.8 158.9	36	38	4	20
HR 50105 HR 50105T	50	63.4	105	227 274.5	30	85 130	14.5	M16	15.5	150 197.5	45	48	5	23
HR 60125	60	74.4	125	329	35	160	18	M20	18	236	55	58	5	26

Model number coding

2 HR4085T UU +1500L P T

Model number
No. of LM blocks used on the same rail

Contamination protection accessory symbol (*1)

LM rail length (in mm)

Symbol for LM rail jointed use

Accuracy symbol (*2)
Normal grade (No Symbol)/High accuracy grade (H)
Precision grade (P)/Super precision grade (SP)
Ultra precision grade (UP)

(*1) See contamination protection accessory on **A1-496**. (*2) See **A1-80**.

Note) One set of model HR means a combination of two LM rails and an LM blocks used on the same plane.

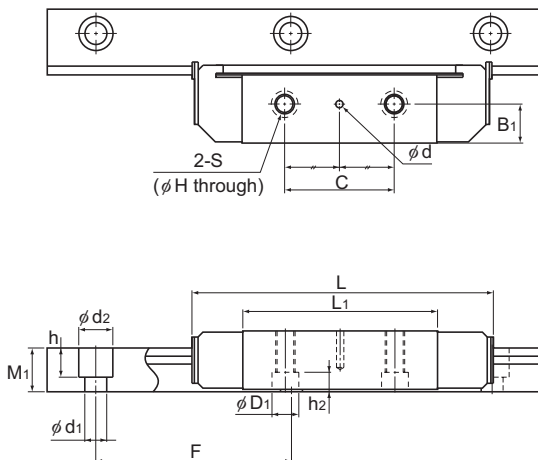

Unit: mm

LM rail dimensions							Basic load rating		Static permissible moment kN·m*				Mass	
Width			Height	Pitch		Length*	C	C ₀	M_A		M_B		LM block	LM rail
W ₁	W ₄	A	M ₁	F	d ₁ × d ₂ × h	Max	kN	kN	1 block	Double blocks	1 block	Double blocks	kg	kg/m
25	12	31.5	22.5	80	9 × 14 × 12	3000	42.6 51.5	44.4 58.1	1.27 2.12	7.71 11.7	1.27 2.12	7.71 11.7	0.7 0.9	4.6
30.5	14.5	37	26	105	11 × 17.5 × 14	3000	53.5 64.4	54.8 71.7	1.75 2.91	10.1 15.2	1.75 2.91	10.1 15.2	1.05 1.4	6.4
35	16	42.5	29	120	14 × 20 × 17	3000	78.8 95.1	78.9 103	3.02 5.02	16.6 25.7	3.02 5.02	16.6 25.7	1.53 1.7	8
42	20	51.5	37	150	18 × 26 × 22	3000	127 153	123 161	5.89 9.81	33.1 51.3	5.89 9.81	33.1 51.3	3.06 3.5	12.1
51	25	65	45	180	22 × 32 × 25	3000	226	232	16	89.5	16	89.5	7.5	19.3

Note) The maximum length under "Length*" indicates the standard maximum length of an LM rail. (See **A1-268**.)

Static permissible moment* 1 block: the static permissible moment value with two LM rails, one LM block per rail, used on the same plane

Double blocks: static permissible moment when two LM blocks are in close contact with each other on two LM rails used on the same plane

A moment in the M_C direction can be received if two rails are used in parallel. However, since it depends on the distance between the two rails, it has been omitted.

Total block length L : The total block length L shown in the table is the length with the dust-proof parts (code: UU).

The M in the model number symbol indicates that the LM block, LM rail and balls are made of stainless steel.

The stainless steel provides excellent corrosion and environmental resistance.