

R Guide Model HCR

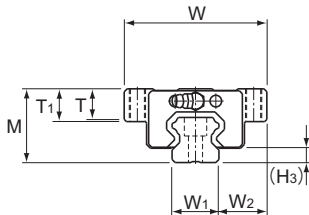

Model No.	Outer dimensions			LM block dimensions									H ₃
	Height	Width	Length	B	C	S	L ₁	T	T ₁	N	E	Grease nipple	
	M	W	L										
HCR 12A+60/100R	18	39	44.6	32	18	M4	30.5	4.5	5	3.4	3.5	PB107	3.1
HCR 15A+60/150R	24	47	54.5	38	24	M5	38.8	10.3	11	4.5	5.5	PB1021B	4.8
HCR 15A+60/300R			55.5										
HCR 15A+60/400R			55.8										
HCR 25A+60/500R	36	70	81.6	57	45	M8	59.5	14.9	16	6	12	B-M6F	7
HCR 25A+60/750R			82.3										
HCR 25A+60/1000R			82.5										
HCR 35A+60/600R	48	100	107.2	82	58	M10	80.4	19.9	21	8	12	B-M6F	8.5
HCR 35A+60/800R			107.5										
HCR 35A+60/1000R			108.2										
HCR 35A+60/1300R			108.5										
HCR 45A+60/800R	60	120	136.7	100	70	M12	98	23.9	25	10	16	B-PT1/8	11.5
HCR 45A+60/1000R			137.3										
HCR 45A+60/1200R			137.3										
HCR 45A+60/1600R			138										
HCR 65A+60/1000R	90	170	193.8	142	106	M16	147	34.9	37	19	16	B-PT1/8	15
HCR 65A+60/1500R			195.4										
HCR 65A+45/2000R			195.9										
HCR 65A+45/2500R			196.5										
HCR 65A+30/3000R			196.5										

Model number coding

HCR25A 2 UU C1 +60 / 1000R H 6 T

Model number

Contamination protection accessory symbol (*1)

R-Guide center angle

LM rail radius (in mm)

Symbol for LM rail jointed use (*5)

No. of LM blocks used on the same rail

Radial clearance symbol (*2)
Normal (No symbol)
Light preload (C1)

Accuracy symbol (*3)
Normal grade (No Symbol)
High accuracy grade (H)

Number of LM rail joints used on one axis (*4)

(*1) See **A1-522** (contamination protection accessories). (*2) See **A1-74**. (*3) See **A1-80**.

(*4) Number of LM rails used for one arc. Contact THK for details.

(*5) When using joined LM rails for models HCR15 to 65, the dust-proofing seal must be a low-resistance end seal (contamination protection accessory symbol: LL).

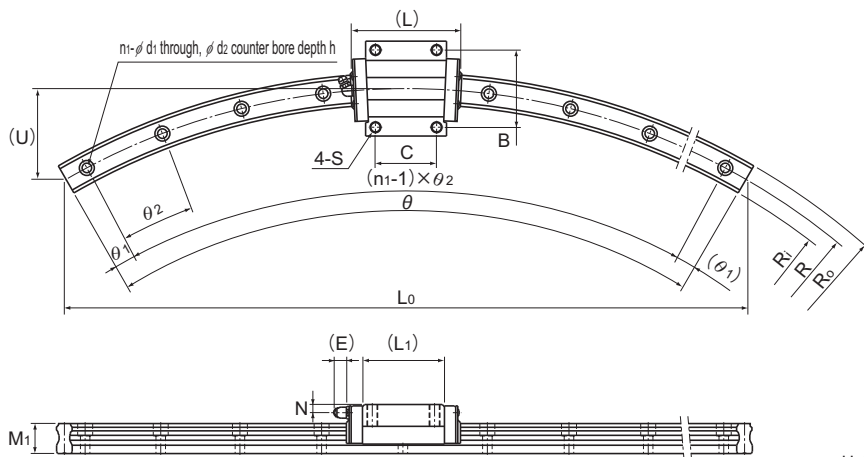

Unit: mm

LM rail dimensions														Basic load rating		Static permissible moment kN·m*					Mass	
R	R ₀	R _i	L ₀	U	W ₁	W ₂	M ₁	d ₁ × d ₂ × h	n ₁	θ°	θ ₁ °	θ ₂ °	C	C ₀	M _A		M _B		M _C	LM block	LM rail	
													kN	kN	1 block	Double blocks	1 block	Double blocks	1 block	kg	kg/m	
100	106	94	100	13.4	12	13.5	11	3.5×6×5	3	60	7	23	4.7	8.53	0.0409	0.228	0.0409	0.228	0.0445	0.08	0.83	
150	157.5	142.5	150	20.1					3	5	7	23	6.66	10.8								
300	307.5	292.5	300	40	15	16	15	4.5×7.5×5.3	5	60	6	12	8.33	13.5	0.0805	0.457	0.0805	0.457	0.0844	0.2	1.5	
400	407.5	392.5	400	54					7	3	9	9	8.33	13.5								
500	511.5	488.5	500	67					9	2	7	7										
750	761.5	738.5	750	100	23	23.5	22	7×11×9	12	60	2.5	5	19.9	34.4	0.307	1.71	0.307	1.71	0.344	0.59	3.3	
1000	1011.5	988.5	1000	134					15	2	4	4										
600	617	583	600	80					7	3	9	9										
800	817	783	800	107	34	33	29	9×14×12	11	60	2.5	5.5	37.3	61.1	0.782	3.93	0.782	3.93	0.905	1.6	6.6	
1000	1017	983	1000	134					12	2.5	5	5										
1300	1317	1283	1300	174					17	2	3.5	3.5										
800	822.5	777.5	800	107					8	2	8	8										
1000	1022.5	977.5	1000	134	45	37.5	38	14×20×17	10	60	3	6	60	95.6	1.42	7.92	1.42	7.92	1.83	2.8	11	
1200	1222.5	1177.5	1200	161					12	2.5	5	5										
1600	1622.5	1577.5	1600	214					15	2	4	4										
1000	1031.5	968.5	1000	134					8	60	2	8										
1500	1531.5	1468.5	1500	201					10	60	3	6										
2000	2031.5	1968.5	1531	152	63	53.5	53	18×26×22	12	45	0.5	4	141	215	4.8	23.5	4.8	23.5	5.82	8.5	22.5	
2500	2531.5	2468.5	1913	190					13	45	1.5	3.5										
3000	3031.5	2968.5	1553	102					10	30	1.5	3										

Note) Static permissible moment*

1 block: the static permissible moment with one LM block

Double blocks: static permissible moment when two LM blocks are in close contact with each other
 : The total block length L shown in the table is the length with the dust proof parts, code UU or SS.
 If other contamination protection accessories or lubricant equipment are installed, the total block length will increase.

(See [A1-497](#) or [A1-518](#))

Please be aware that balls will fall out if the LM block is removed from the LM rail.

LM rail radii other than those shown in the table are also available. Contact THK for details.

The θ° in the table represents the maximum manufacturing angle. Exceeding this angle is normally done by using a joint; however, some parts may have LM rails that exceed the maximum manufacturing angle. Contact THK for details.