

Model LBF (Medium Load Type)

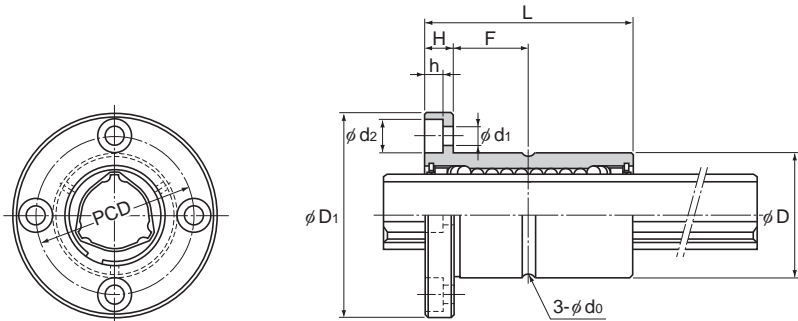

Model No.	Spline nut dimensions									
	Outer diameter		Length		Flange diameter		H	F	Greasing hole d _o	PCD
	D	Tolerance	L	Tolerance	D ₁	Tolerance				
LBF 15	23	⁰ -0.013	40	⁰ -0.2	43	0 -0.2	7	13	2	32
○● LBF 20	30	0 -0.016	50	0 -0.3	49		7	18	2	38
○● LBF 25	37		60		60	9	21	2	47	
○● LBF 30	45	70	70	10	25	3	54			
○● LBF 40	57	0 -0.019	90	0 -0.3	90	14	31	3	70	
○● LBF 50	70		100		108	16	34	4	86	
○ LBF 60	85	0 -0.022	127	0 -0.4	124	0 -0.3	18	45.5	4	102
○● LBF 70	95		110		142		20	35	4	117
○● LBF 85	115	140	168	22	48	5	138			
○● LBF 100	135	⁰ -0.025	160	⁰ -0.4	195	⁰ -0.4	25	55	5	162

Note) ○: indicates model numbers for which high temperature types are available (with metal retainer; service temperature: up to 100°C).

(Example) LBF20 A CL+500L H

└ High temperature symbol

- : indicates model numbers for which felt seal types are available (see **A3-122**).
A felt seal cannot be attached to Ball Spline models using metal retainer.

Model number coding

2	LBF20	DD	CL	+900L	P	K
┆	┆	┆	┆	┆	┆	┆
Model No.		Symbol for clearance in the rotational direction (*2)		Accuracy symbol (*3)		Symbol for spline shaft (*4)
Number of spline nuts on one shaft (no symbol for one nut) (*1)	Contamination protection accessory symbol		Overall spline shaft length (*5) (in mm)			

(*1) See **A3-122**. (*2) See **A3-30**. (*3) See **A3-35**. (*4) See **A3-71**. (*5) See **A3-117**.

High Torque Type Ball Spline

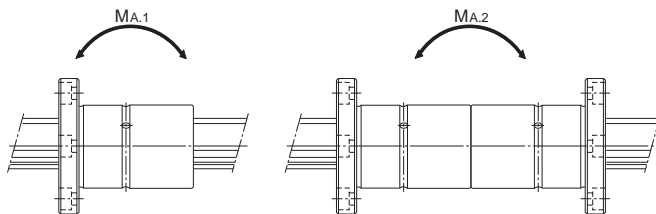

Unit: mm

Mounting hole $d_1 \times d_2 \times h$		Basic torque rating		Basic load rating (radial)		Static permissible moment		Mass	
		C_T N•m	C_{0T} N•m	C kN	C_0 kN	M_{A1}^{**} N•m	M_{A2}^{**} N•m	Spline Nut kg	Spline shaft kg/m
	4.5×8×4.4	30.4	74.5	4.4	8.4	25.4	185	0.11	1
	4.5×8×4.4	74.5	160	7.8	14.9	60.2	408	0.2	1.8
	5.5×9.5×5.4	154	307	13	23.5	118	760	0.36	2.7
	6.6×11×6.5	273	538	19.3	33.8	203	1270	0.6	3.8
	9×14×8.6	599	1140	31.9	53.4	387	2640	1.2	6.8
	11×17.5×11	1100	1940	46.6	73	594	4050	1.9	10.6
	11×17.5×11	1870	3830	66.2	121	1300	8280	3.5	15.6
	14×20×13	2190	3800	66.4	102	895	6530	3.6	21.3
	16×23×15.2	3620	6360	90.5	141	2000	12600	6.2	32
	18×26×17.5	5910	12600	126	237	3460	20600	11	45

Note) M_{A1}^{**} indicates the permissible moment value in the axial direction when a single spline nut is used, as shown in the figure above.

M_{A2}^{**} indicates the permissible moment value in the axial direction when two spline nuts in close contact with each other are used, as shown in the figure above.

For details on the maximum lengths of ball spline shafts by accuracy, please see **A3-117**.