

EBB-V

Oversized-ball Preload / No Preload

DN value	130000
----------	--------

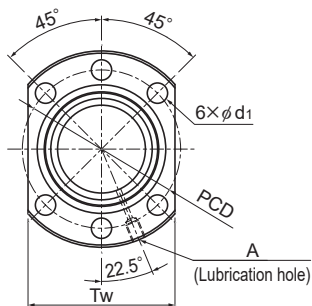

Model No.	Screw shaft outer diameter d	Lead Ph	Ball center-to-center diameter dp	Thread minor diameter dc	Loaded circuits Rows x turns	Basic load rating		Rigidity K N/μm
						Ca kN	C _{0a} kN	
EBB 1605V-4	16	5	16.75	13.49	4×1	11.9	17.4	207
EBB 2004V-8	20	4	20.5	18.06	8×1	14.9	30.9	487
EBB 2005V-3	20	5	20.75	17.49	3×1	10.6	17.3	198
EBB 2006V-6	20	6	21	16.93	6×1	25.0	40.8	376
EBB 2008V-6	20	8	21	16.93	6×1	24.9	40.8	375
EBB 2010V-6	20	10	21.25	16.36	6×1	31.4	49.0	385
EBB 2504V-8	25	4	25.5	23.06	8×1	16.4	39.0	583
EBB 2505V-3	25	5	25.75	22.49	3×1	12.1	22.6	245
EBB 2506V-6	25	6	26	21.93	6×1	29.0	54.1	472
EBB 2508V-6	25	8	26	21.93	6×1	28.9	54.1	472
EBB 2510V-3	25	10	26	21.93	3×1	15.9	27.0	243
EBB 2510V-4	25	10	26	21.93	4×1	20.9	37.6	320
EBB 2512V-4	25	12	26.25	21.36	4×1	25.4	42.3	322
EBB 2806V-6	28	6	29	24.93	6×1	31.7	64.1	542
EBB 3204V-10	32	4	32.5	30.06	10×1	22.3	63.9	892
EBB 3205V-3	32	5	32.75	29.49	3×1	13.9	30.2	308
EBB 3205V-4	32	5	32.75	29.49	4×1	17.8	40.3	405
EBB 3205V-6	32	5	32.75	29.49	6×1	25.1	60.4	597
EBB 3206V-8	32	6	33	28.93	8×1	43.3	98.9	800
EBB 3208V-8	32	8	33.25	28.36	8×1	52.9	110.5	772
EBB 3210V-3	32	10	33.75	27.24	3×1	32.1	52.2	301
EBB 3210V-4	32	10	33.75	27.24	4×1	41.3	69.7	396
EBB 3604V-6	36	4	36.5	34.04	6×1	15.3	44.3	616
EBB 3606V-8	36	6	37	32.93	8×1	45.8	112.4	885
EBB 3608V-8	36	8	37.25	32.36	8×1	57.4	129.7	879

Note) When the QZ Lubricator and W wiper ring are attached, the overall length of the nut dimensions will increase. Contact THK for details.

Model number coding

EBB3205V-6 RR G0 +650L C3

Model No.

Clearance symbol

Accuracy symbol

Ball screw shaft length (mm)

Seal symbol (RR : Labyrinth seal, WW : Wiper ring.)

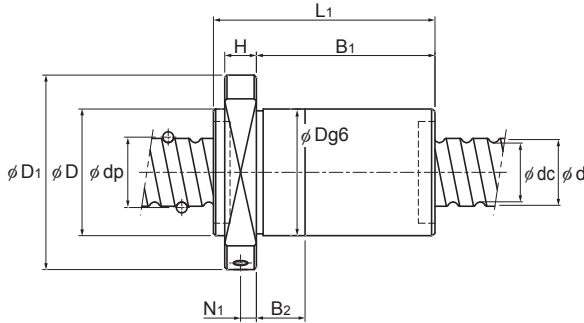

Unit: mm

	Nut dimensions										Nut mass kg	Shaft mass kg/m
	Outer diameter D	Flange diameter D ₁	Overall length L ₁	H	B ₁	B ₂	PCD	d ₁	T _w	Lubrication hole A		
28	48	55	10	40	12	38	5.5	40	M6	0.20	1.35	
36	58	69	10	54	12	47	6.6	44	M6	0.31	2.26	
36	58	50	10	35	12	47	6.6	44	M6	0.30	2.17	
36	58	73	10	58	12	47	6.6	44	M6	0.40	2.11	
36	58	87	10	72	15	47	6.6	44	M6	0.47	2.20	
36	58	102	10	87	15	47	6.6	44	M6	0.52	2.14	
40	62	70	10	55	12	51	6.6	48	M6	0.34	3.58	
40	62	50	10	35	12	51	6.6	48	M6	0.32	3.48	
40	62	74	10	59	12	51	6.6	48	M6	0.42	3.40	
40	62	88	10	73	15	51	6.6	48	M6	0.50	3.51	
40	62	69	10	54	18	51	6.6	48	M6	0.42	3.57	
40	62	81	10	66	18	51	6.6	48	M6	0.48	3.57	
40	62	91	10	76	18	51	6.6	48	M6	0.49	3.50	
42	71	72	12	60	15	57	6.6	55	M6	0.51	4.32	
50	80	81	12	64	15	65	9	62	M6	0.81	5.95	
50	80	52	12	35	12	65	9	62	M6	0.56	5.82	
50	80	57	12	40	12	65	9	62	M6	0.60	5.82	
50	80	67	12	50	12	65	9	62	M6	0.67	5.82	
50	80	95	12	78	15	65	9	62	M6	0.88	5.71	
50	80	117	12	100	18	65	9	62	M6	1.00	5.63	
50	80	78	12	61	18	65	9	62	M6	0.67	5.45	
50	80	90	12	73	18	65	9	62	M6	0.75	5.45	
56	86	58	14	44	15	70	9	65	M6	0.96	7.58	
56	86	92	14	78	15	70	9	65	M6	1.09	7.31	
56	86	112	14	98	20	70	9	65	M6	1.22	7.21	

Note) The rigidity values in the table represent spring constants each obtained from the load and the Elastic Deformation finish when providing an axial load 24% of the basic dynamic load rating (Ca).

These values do not include the rigidity of the components related to mounting the nut. Therefore, it is normally appropriate to regard roughly 80% of the value in the table as the actual value.

If the axial load (Fa) is not 0.3 Ca, the rigidity value (K_N) is obtained from the following equation.

$$K_N = K \left(\frac{Fa}{0.3Ca} \right)^{\frac{1}{3}}$$

K: Rigidity value in the dimensional table