

# BLR (Precision Ball Screw) No Preload

DN value	70000
----------	-------

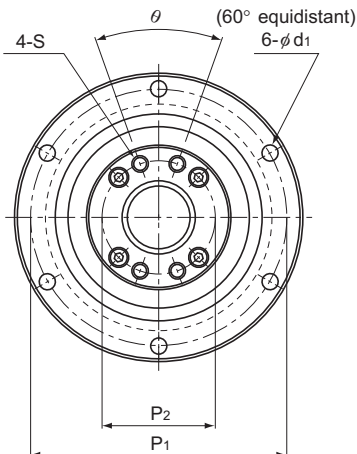

Model No.	Screw shaft outer diameter d	Thread minor diameter dc	Lead Ph	Ball center-to-center diameter dp	Basic load rating		Outer diameter D	Flange diameter D <sub>1</sub>	Overall length L <sub>1</sub>	D <sub>3</sub>
					Ca kN	C <sub>0a</sub> kN				
BLR 1616-3.6	16	13.7	16	16.65	7.1	14.3	52 <sup>0</sup> <sub>-0.007</sub>	68	43.5	40 <sup>0</sup> <sub>-0.025</sub>
BLR 2020-3.6	20	17.5	20	20.75	11.1	24.7	62 <sup>0</sup> <sub>-0.007</sub>	78	54	50 <sup>0</sup> <sub>-0.025</sub>
BLR 2525-3.6	25	21.9	25	26	16.6	38.7	72 <sup>0</sup> <sub>-0.007</sub>	92	65	58 <sup>0</sup> <sub>-0.03</sub>
BLR 3232-3.6	32	28.3	32	33.25	23.7	59.5	80 <sup>0</sup> <sub>-0.007</sub>	105	80	66 <sup>0</sup> <sub>-0.03</sub>
BLR 3636-3.6	36	31.7	36	37.4	30.8	78	100 <sup>0</sup> <sub>-0.008</sub>	130	93	80 <sup>0</sup> <sub>-0.03</sub>
BLR 4040-3.6	40	35.2	40	41.75	38.7	99.2	110 <sup>0</sup> <sub>-0.008</sub>	140	98	90 <sup>0</sup> <sub>-0.035</sub>
BLR 5050-3.6	50	44.1	50	52.2	57.8	155	120 <sup>0</sup> <sub>-0.008</sub>	156	126	100 <sup>0</sup> <sub>-0.035</sub>

## Model number coding

**BLR2020-3.6 K UU G1 +1000L C5**

Model number    Flange orientation symbol    Symbol for clearance in the axial direction <sup>(\*)2</sup>    Accuracy symbol <sup>(\*)3</sup>  
 Symbol for support bearing seal <sup>(\*)1</sup>    Overall screw shaft length (in mm)

(\*)1 UU: Seal attached on both ends No symbol: Without seal. (\*)2 See **A15-19**. (\*)3 See **A15-12**.

## Rotary Nut Ball Screw

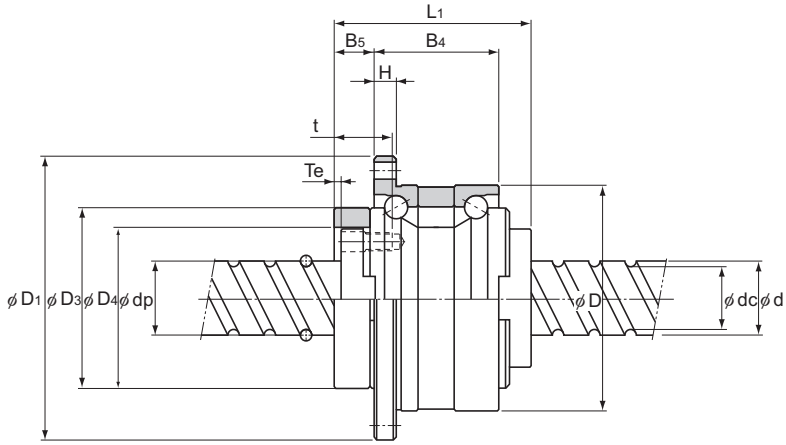

Unit: mm

Ball screw dimensions												Support bearing basic load rating		Nut inertial moment kg·m <sup>2</sup>	Nut mass kg	Shaft mass kg/m
D <sub>4</sub>	H	B <sub>4</sub>	B <sub>5</sub>	T <sub>e</sub>	P <sub>1</sub>	P <sub>2</sub>	S	t	d <sub>1</sub>	θ°	C <sub>a</sub> kN	C <sub>0a</sub> kN				
32 <sup>+0.025</sup> <sub>0</sub>	5	27.5	9	2	60	25	M4	12	4.5	40	19.4	19.2	4.80 × 10 <sup>-6</sup>	0.38	1.41	
39 <sup>+0.025</sup> <sub>0</sub>	6	34	11	2	70	31	M5	16	4.5	40	26.8	29.3	1.44 × 10 <sup>-4</sup>	0.68	2.25	
47 <sup>+0.025</sup> <sub>0</sub>	8	43	12.5	3	81	38	M6	19	5.5	40	28.2	33.3	3.23 × 10 <sup>-4</sup>	1.1	3.52	
58 <sup>+0.03</sup> <sub>0</sub>	9	55	14	3	91	48	M6	19	6.6	40	30	39	6.74 × 10 <sup>-4</sup>	1.74	5.83	
66 <sup>+0.03</sup> <sub>0</sub>	11	62	17	3	113	54	M8	22	9	40	56.4	65.2	1.68 × 10 <sup>-3</sup>	3.2	7.34	
73 <sup>+0.03</sup> <sub>0</sub>	11	68	16.5	3	123	61	M8	22	9	50	59.3	74.1	2.79 × 10 <sup>-3</sup>	3.95	9.01	
90 <sup>+0.035</sup> <sub>0</sub>	12	80	25	4	136	75	M10	28	11	50	62.2	83	5.82 × 10 <sup>-3</sup>	6.22	14.08	

Ball Screw