

## EK Square Type Support Unit on the Fixed Side

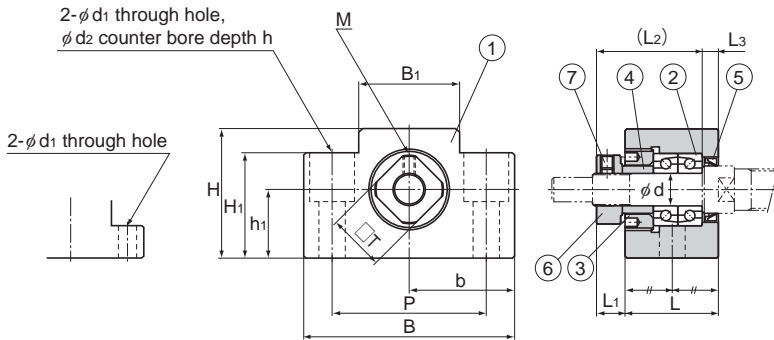

Models EK 4 and 5

Models EK 6 and 8

Model No.	Shaft diameter d	L	L <sub>1</sub>	L <sub>2</sub>	L <sub>3</sub>	B	H	b ±0.02
EK 4	4	15	5.5	17.5	3	34	19	17
EK 5	5	16.5	5.5	18.5	3.5	36	21	18
EK 6	6	20	5.5	22	3.5	42	25	21
EK 8	8	23	7	26	4	52	32	26
EK 10	10	24	6	29.5	6	70	43	35
EK 12	12	24	6	29.5	6	70	43	35
EK 15	15	25	6	36	5	80	49	40
EK 20	20	42	10	50	10	95	58	47.5

Models EK 4 to 8

Part No.	Part name	No. of units
1	Housing	1
2	Bearing	1 set
3	Set nut	1
4	Collar	2
5	Seal	1
6	Lock Nut	1
7	Hexagonal socket-head setscrew (with a set piece)	1

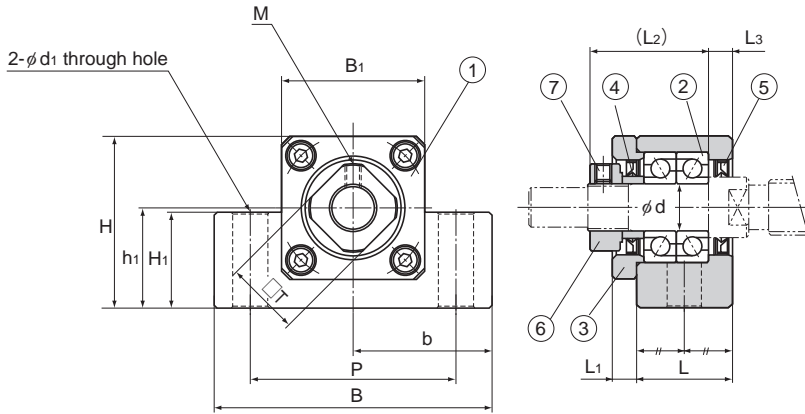

Models EK 10 to 20

Unit: mm

$h_1$ $\pm 0.02$	$B_1$	$H_1$	P	$d_1$	$d_2$	h	M	T	Bearing used	Mass kg
10	18	7	26	4.5	—	—	M2.6	10	AC4-12(DF P5)	0.06
11	20	8	28	4.5	—	—	M2.6	11	AC5-14(DF P5)	0.08
13	18	20	30	5.5	9.5	11	M3	12	AC6-16(DF P5)	0.14
17	25	26	38	6.6	11	12	M3	14	79M8A(DF P5)	0.24
25	36	24	52	9	—	—	M3	16	7000 equivalent (DF P5)	0.46
25	36	24	52	9	—	—	M3	19	7001 equivalent (DF P5)	0.44
30	41	25	60	11	—	—	M3	22	7002 equivalent (DF P5)	0.55
30	56	25	75	11	—	—	M4	30	7204 equivalent (DF P5)	1.35

Models EK 10 to 20

Part No.	Part name	No. of units
1	Housing	1
2	Bearing	1 set
3	Holding lid	1
4	Collar	2
5	Seal	2
6	Lock Nut	1
7	Hexagonal socket-head setscrew (with a set piece)	1