

## Model RB (Separable Outer Ring Type)

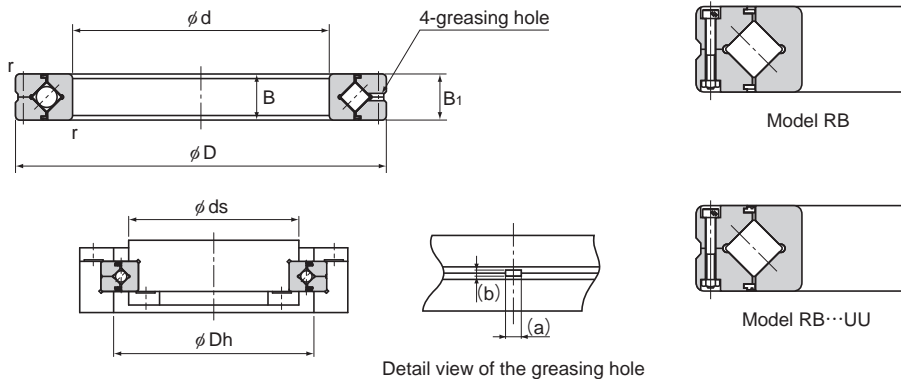

Detail view of the greasing hole

Unit: mm

Shaft diameter	Model No.	Main dimensions							Shoulder height		Basic load rating (radial)		Mass
		Inner diameter d	Outer diameter D	Roller pitch circle diameter dp	Width B B <sub>1</sub>	Greasing hole		r <sub>min</sub>	ds (max)	Dh (min)	C	C <sub>0</sub>	
						a	b						
20	RB 2008	20	36	27	8	2	0.8	0.5	23.5	30.5	3.23	3.1	0.04
25	RB 2508	25	41	32	8	2	0.8	0.5	28.5	35.5	3.63	3.83	0.05
30	RB 3010	30	55	41.5	10	2.5	1	0.6	37	47	7.35	8.36	0.12
35	RB 3510	35	60	46.5	10	2.5	1	0.6	41	51.5	7.64	9.12	0.13
40	RB 4010	40	65	51.5	10	2.5	1	0.6	46.5	57.5	8.33	10.6	0.16
45	RB 4510	45	70	56.5	10	2.5	1	0.6	51	61.5	8.62	11.3	0.17
50	RB 5013	50	80	64	13	2.5	1.6	0.6	57	72	16.7	20.9	0.27
60	RB 6013	60	90	74	13	2.5	1.6	0.6	67	82	18	24.3	0.3
70	RB 7013	70	100	84	13	2.5	1.6	0.6	77	92	19.4	27.7	0.35
80	RB 8016	80	120	98	16	3	1.6	0.6	88	110	30.1	42.1	0.7
90	RB 9016	90	130	108	16	3	1.6	1	98	118	31.4	45.3	0.75
100	RB 10016	100	140	119.3	16	3.5	1.6	1	109	129	31.7	48.6	0.83
	RB 10020		150	123	20	3.5	1.6	1	113	133	33.1	50.9	1.45
110	RB 11012	110	135	121.8	12	2.5	1	0.6	117	128	12.5	24.1	0.4
	RB 11015		145	126.5	15	3.5	1.6	0.6	119	136	23.7	41.5	0.75
	RB 11020		160	133	20	3.5	1.6	1	120	143	34	54	1.56
120	RB 12016	120	150	134.2	16	3.5	1.6	0.6	127	141	24.2	43.2	0.72
	RB 12025		180	148.7	25	3.5	2	1.5	133	164	66.9	100	2.62
	RB 13015		130	160	144.5	15	3.5	1.6	0.6	137	152	25	46.7
RB 13025	190	158		25	3.5	2	1.5	143	174	69.5	107	2.82	

Note1) The model number of a type with seals attached is RB...UU.

If a certain level of accuracy is required, this model is used for inner ring rotation.

Note2) (a) and (b) dimensions of the greasing hole in the detailed diagram are reference values.

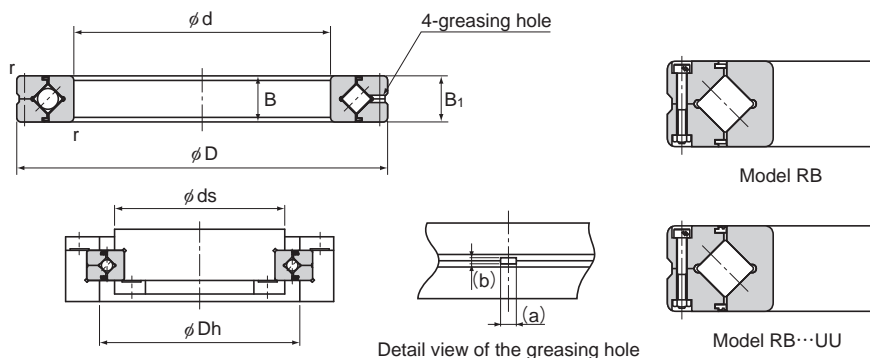

Unit: mm

Shaft diameter	Model No.	Main dimensions							Shoulder height		Basic load rating (radial)		Mass kg
		Inner diameter d	Outer diameter D	Roller pitch circle diameter dp	Width B B <sub>1</sub>	Greasing hole		r <sub>min</sub>	ds (max)	Dh (min)	C kN	C <sub>0</sub> kN	
						a	b						
140	RB 14016	140	175	154.8	16	2.5	1.6	1	147	162	25.9	50.1	1
	RB 14025		200	168	25	3.5	2	1.5	154	185	74.8	121	2.96
150	RB 15013	150	180	164	13	2.5	1.6	0.6	157	172	27	53.5	0.68
	RB 15025		210	178	25	3.5	2	1.5	164	194	76.8	128	3.16
	RB 15030		230	188	30	4.5	3	1.5	169	211	100	156	5.3
160	RB 16025	160	220	188.6	25	3.5	2	1.5	173	204	81.7	135	3.14
170	RB 17020	170	220	191	20	3.5	1.6	1.5	184	198	29	62.1	2.21
180	RB 18025	180	240	210	25	3.5	2	1.5	195	225	84	143	3.44
190	RB 19025	190	240	211.9	25	3.5	1.6	1	202	222	41.7	82.9	2.99
	RB 20025		260	230	25	3.5	2	2	215	245	84.2	157	4
200	RB 20030	200	280	240	30	4.5	3	2	221	258	114	200	6.7
	RB 20035		295	247.7	35	5	3	2	225	270	151	252	9.6
	RB 22025		220	280	250.1	25	3.5	2	2	235	265	92.3	171
240	RB 24025	240	300	269	25	3.5	2	2.5	256	281	68.3	145	4.5
250	RB 25025	250	310	277.5	25	3.5	2	2.5	265	290	69.3	150	5
	RB 25030		330	287.5	30	4.5	3	2.5	269	306	126	244	8.1
	RB 25040		355	300.7	40	6	3.5	2.5	275	326	195	348	14.8
300	RB 30025	300	360	328	25	3.5	2	2.5	315	340	76.3	178	5.9
	RB 30035		395	345	35	5	3	2.5	322	368	183	367	13.4
	RB 30040		405	351.6	40	6	3.5	2.5	326	377	212	409	17.2
350	RB 35020	350	400	373.4	20	3.5	1.6	2.5	363	383	54.1	143	3.9

Note1) The model number of a type with seals attached is RB...UU.

If a certain level of accuracy is required, this model is used for inner ring rotation.

Note2) (a) and (b) dimensions of the greasing hole in the detailed diagram are reference values.

## Model number coding

**RB3010 UU CC0 P5**

Model number

Accuracy symbol (\*2)

Radial clearance symbol (\*1)

Seal attached on both ends (seal attached on either end: U)

(\*1) See **A18-18**. (\*2) See **A18-13**.