

Cam Follower with Hexagon Socket Model CF-A

Optional specifications		Symbol
Roller guide	With cage	No Symbol
	Full rollers	V
Material	Carbon steel	No Symbol
	Stainless steel	M
Seal	Without seal	No Symbol
	With seal	UU
Outer ring shape	Cylindrical outer ring	No Symbol
	Spherical outer ring	R

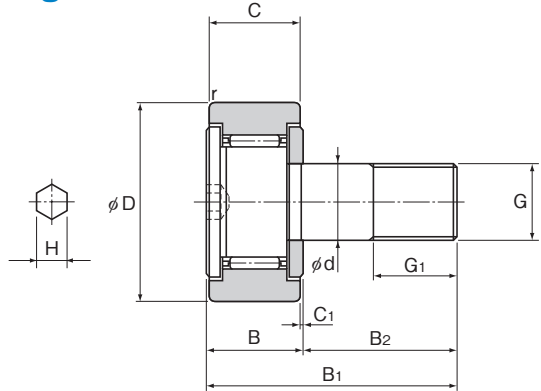

Stud diameter	Model No.	Main dimensions										
		Outer diameter	Outer ring width	Threaded			Overall length					Shoulder height f (Min.)
d		D	C	G	G ₁	B	B ₁	B ₂	C ₁	H*	r _{min}	
3	CF 3-A	10	7	M3×0.5	5	8	17	9	0.5	2 (1.5)	0.2	6.8
4	CF 4-A	12	8	M4×0.7	6	9	20	11	0.5	2.5 (2)	0.3	8.6
5	CF 5-A	13	9	M5×0.8	7.5	10	23	13	0.5	3 (2.5)	0.3	9.7
6	CF 6-A	16	11	M6×1	8	12	28	16	0.6	3	0.3	11
8	CF 8-A	19	11	M8×1.25	10	12	32	20	0.6	4	0.3	13
10	CF 10-A	22	12	M10×1.25	12	13	36	23	0.6	5	0.3	15
10	CF 10-1-A	26	12	M10×1.25	12	13	36	23	0.6	5	0.3	15

Note) For information on accuracy standards, please refer to **A19-14**.
Those models do not have a greasing hole and cannot be replenished with grease.

Model number coding

CF10 V M UU R -A

Model No.
 No symbol: With cage
 V : Full-roller Type
 No symbol: Carbon steel
 M : Stainless steel
 no symbol: without seal
 UU : With seal
 No symbol: Cylindrical outer ring
 R : Spherical outer ring
 Stud head with a hexagon socket

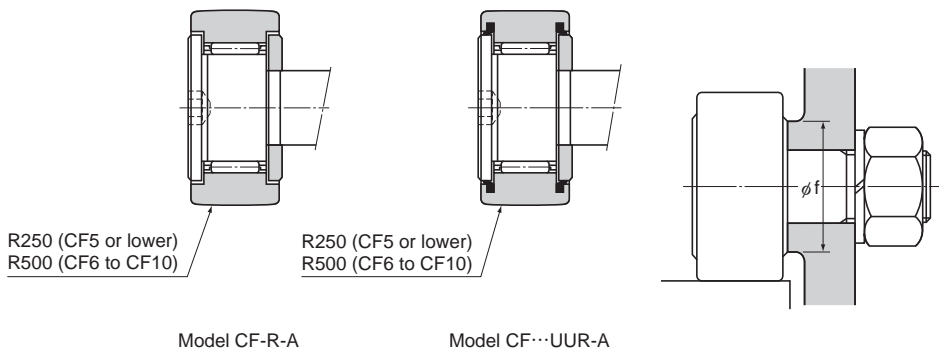

Unit: mm

	Basic load rating				Maximum permissible load F_0 kN	Track load capacity		Rotational speed limit *		Mass	
	With cage		Full rollers			Cylindrical outer ring kN	Spherical outer ring kN	With cage min^{-1}	Full rollers min^{-1}	With cage g	Full rollers g
	C kN	C_0 kN	C kN	C_0 kN							
	1.47	1.18	2.8	2.5	0.36	1.37	0.37	47000	18800	4.5	5
	2.06	2.05	4	4.3	0.78	1.76	0.47	37000	14800	7.5	8
	3.14	2.77	5.1	5.5	1.42	2.25	0.53	29000	11600	10.5	11
	3.59	3.58	6.94	8.5	2.11	3.43	1.08	25000	11000	18.5	19
	4.17	4.65	8.13	11.2	4.73	4.02	1.37	20000	8700	28.5	29
	5.33	6.78	9.42	14.3	5.81	4.7	1.67	17000	7200	45	46
	5.33	6.78	9.42	14.3	5.81	5.49	2.06	17000	7200	60	61

Note1) "★" indicates that the dimensions in the parentheses in this row apply to stainless steel types.

The rotation speed limit value in the table (*) applies to models that have no seal and use grease lubrication. With those models using oil lubrication, up to 130% of this value is permitted. With those attached with seals, up to 70% of this value is permitted.