

# HMG

## LM Guide Straight-Curved Guide Model HMG

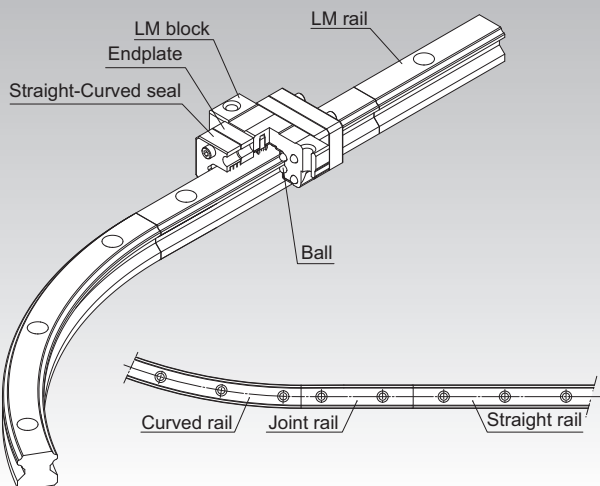

**Point of Selection** **A1-10**

**Point of Design** **A1-460**

**Options** **A1-485**

**Model No.** **A1-551**

**Precautions on Use** **A1-557**

**Accessories for Lubrication** **A24-1**

**Mounting Procedure and Maintenance** **B1-89**

Equivalent Moment Factor **A1-43**

Rated Loads in All Directions **A1-60**

Equivalent Factor in Each Direction **A1-62**

Radial Clearance **A1-74**

Accuracy Standards **A1-79**

Shoulder Height of the Mounting Base and the Corner Radius **A1-471**

Dimensions of Each Model with Options Attached **A1-499**

## Structure and Features

The Straight-Curved Guide HMG is a new straight-curved guide that allows the same type of LM blocks to continuously move on straight and curved rails by combining the technologies of the LM Guide HSR and the R Guide HCR. It achieves drastic cost reduction through improvement of work efficiency at the assembly and conveyance lines and the inspection equipment and simplification of the structure by eliminating a lift and a table.

### [Freedom of Design]

It allows free combinations of straight and curved shapes.

Since LM blocks can smoothly transit between the straight and curved sections, various combinations of straight and curved rails can be joined into various shapes such as O, U, L and S shapes. In addition, HMG allows a large table to be mounted and a heavy object to be carried through combinations of multiple blocks on a single rail or 2 or more LM rails. Thus, it provides great freedom of design.

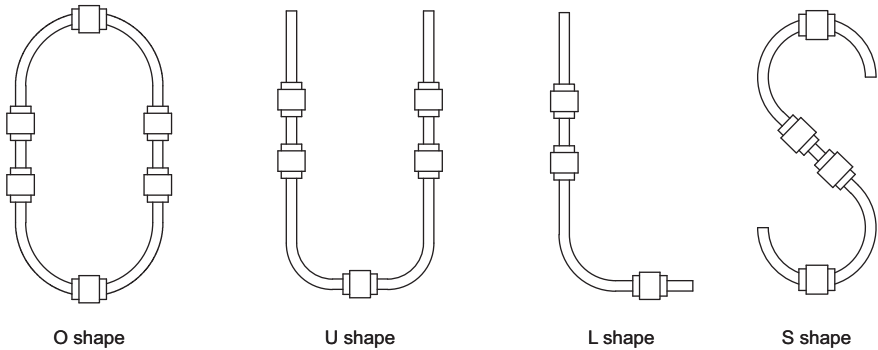

Fig.1 Examples of Joining Rails into Different Shapes

### [Straight-Curved Seals]

The Model HMG is available with seals that can be used for both straight and curved sections to prevent foreign materials from entering. These straight-curved seals provide sealing for both the straight and curved sections, preventing foreign materials from entering the unit.

### [Shortened Transportation Time]

Unlike the shuttle method, using HMG units in a circulating system allows workpieces to be placed while other workpieces are being inspected or mounted, thus to significantly improve process time. Increasing the number of tables can further shorten process time.

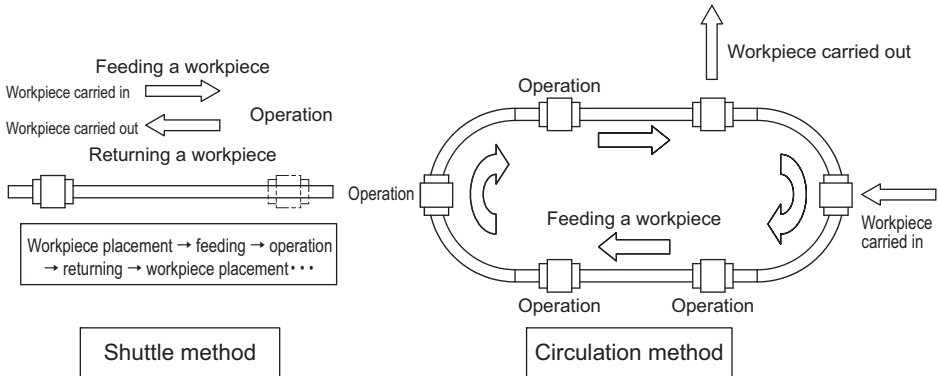

Fig.2 Improved process time

### [Cost Reduction through a Simplified Mechanism]

Combination of straight and curved rails eliminates a lift and a turntable conventionally used for changing directions in the conveyance and production lines. Therefore, use of HMG simplifies the mechanism and eliminates a large number of parts, allowing the cost to be reduced. Additionally, man-hours in designing can also be reduced.

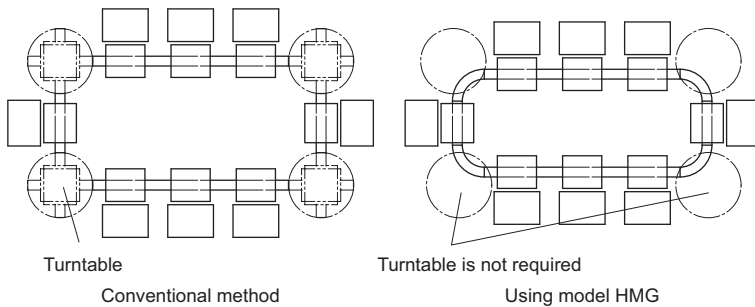

Fig.3

---

## Types and Features

---

### Model HMG

The flange of the LM block has tapped holes. Can be mounted from the top or the bottom.

Specification Table → **A1-344**

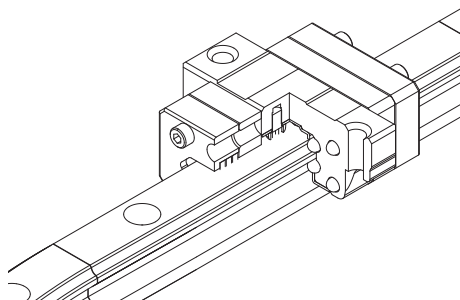

LM Guide

## Examples of Table Mechanisms

The Straight-Curved Guide HMG requires a rotating mechanism or a slide mechanism for the table to rotate the curved sections when 2 or more rails are used or when 2 or more LM blocks are connected on a single rail. Refer to Fig.4 for examples of such mechanisms.

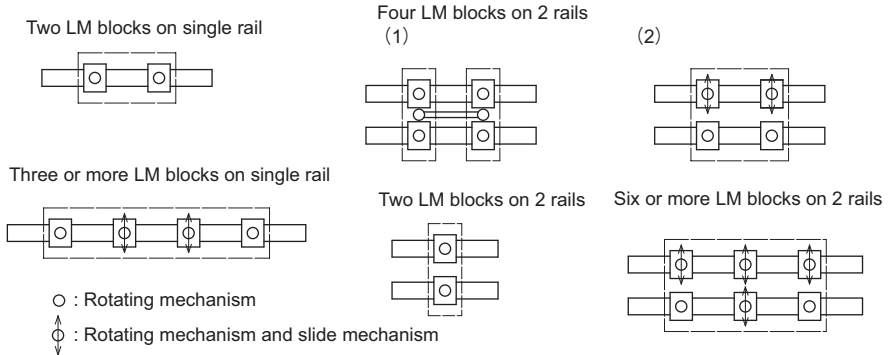

Fig.4 Examples of Table Mechanisms

Fig.5 shows examples of designing a table when units are used on multiple axes. HMG requires a rotating mechanism and a slide mechanism since the table is decentered when an LM block transits from a straight section to a curved section. The amount of decentering differs according to the radius of the curved section and the LM block span. Therefore, it is necessary to design the system in accordance with the corresponding specifications.

Fig.6 shows detail drawings of the slide and rotating mechanisms. In the figure, LM Guides are used in the slide mechanism and Cross-Roller Rings in the rotating mechanism to achieve smooth sliding and rotating motions.

For driving the Straight-Curved Guide, belt drives and chain drives are available.

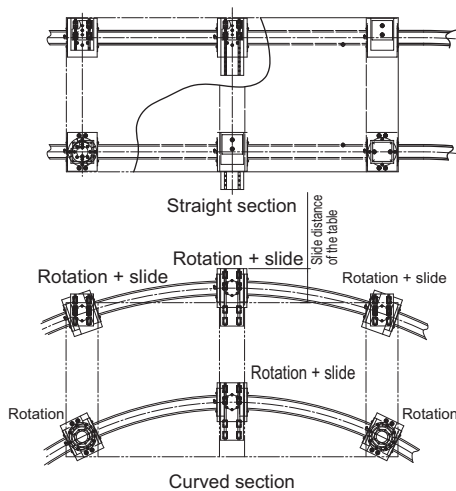

Fig.5

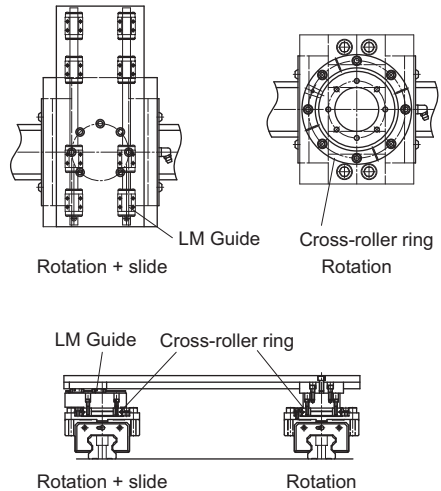
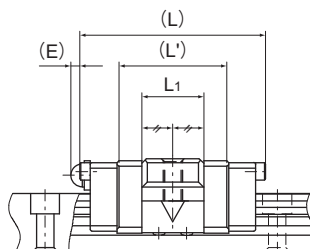
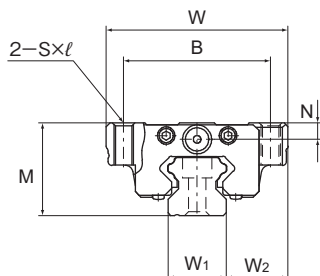

Fig.6



# Model HMG



Model No.	Outer dimensions				LM block dimensions					LM rail dimensions			
	M	W	L	L'	B	S×ℓ	L <sub>1</sub>	N	E	LM rail			Height M <sub>1</sub>
										W <sub>1</sub>	W <sub>2</sub>	F	
HMG 15A	24	47	48	28.8	38	M5×11	16	4.3	5.5	15	16	60	15
HMG 25A	36	70	62.2	42.2	57	M8×16	25.6	6	12	23	23.5	60	22
HMG 35A	48	100	80.6	54.6	82	M10×21	32.6	8	12	34	33	80	29
HMG 45A	60	120	107.6	76.6	100	M12×25	42.6	10	16	45	37.5	105	38
HMG 65A	90	170	144.4	107.4	142	M16×37	63.4	19	16	63	53.5	150	53

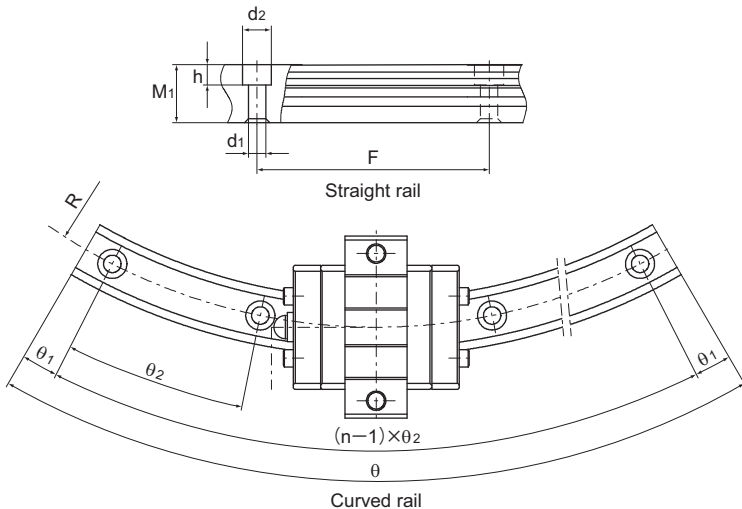

Unit: mm

	Mounting hole $d_1 \times d_2 \times h$	Curved rail					Basic dynamic load rating (C) Resultant load (C) kN	Basic static load rating ( $C_0$ )	
		R	n	$\theta^\circ$	$\theta_1^\circ$	$\theta_2^\circ$		Straight section (Cost) kN	Curved section (Cor) kN
	4.5×7.5×5.3	150	3	60	7	23	2.56	4.23	0.44
		300	5	60	6	12			
		400	7	60	3	9			
	7×11×9	500	9	60	2	7	9.41	10.8	6.7
		750	12	60	2.5	5			
		1000	15	60	2	4			
	9×14×12	600	7	60	3	9	17.7	19	11.5
		800	11	60	2.5	5.5			
		1000	12	60	2.5	5			
	14×20×17	1300	17	60	2	3.5	28.1	29.7	18.2
		800	8	60	2	8			
		1000	10	60	3	6			
	18×26×22	1200	12	60	2.5	5	66.2	66.7	36.2
		1600	15	60	2	4			
		1000	8	60	2	8			
		1500	10	60	3	6			
		2000	12	45	0.5	4			
		2500	13	45	1.5	3.5			
		3000	10	30	1.5	3			

Note) When a moment is applied where one LM block is specified per axis, the LM block may experience non-smooth motion. We recommend that multiple LM blocks be used per axis when a moment is applied.

Static permissible moment (straight/curved components): the static permissible moment value with 1 LM block (see Table1)

Total block length L: The total block length L shown in the table is the length including the straight-curved seal (code: UU).

Table1 Static Permissible Moments of Model HMG

Unit: kN·m

Model No.	$M_A$		$M_B$		$M_C$	
	Straight section	Curved section	Straight section	Curved section	Straight section	Curved section
HMG 15	0.008	0.007	0.008	0.01	0.027	0.003
HMG 25	0.1	0.04	0.1	0.05	0.11	0.07
HMG 35	0.22	0.11	0.22	0.12	0.29	0.17
HMG 45	0.48	0.2	0.48	0.22	0.58	0.34
HMG 65	1.47	0.66	1.47	0.73	1.83	0.94



## Jointed LM rail

### [Level Difference Specification for the Joint]

An accuracy error in LM rail installation has influence on the service life of the product. When installing the LM rail, take care to minimize the level difference in the joint within the specification indicated in Table2. For the joint between curved rails and another between the curved section and the joint rail, we recommend using a flushing piece like the one shown in Fig.7. When using the flushing piece, place the fixed butt piece on the outer side, push the rail against the butt piece, and then adjust the level difference in the joint section by turning the adjustment screw from the inner side.

Table2 Level Difference Specification for the Joint

Unit: mm

Model No.	Ball raceway, side face	Upper face	Maximum clearance of the joint section
15	0.01	0.02	0.6
25	0.01	0.02	0.7
35	0.01	0.02	1.0
45	0.01	0.02	1.3
65	0.01	0.02	1.3

Note) Place the pin on the outer circumference and the bolt on the inner circumference.

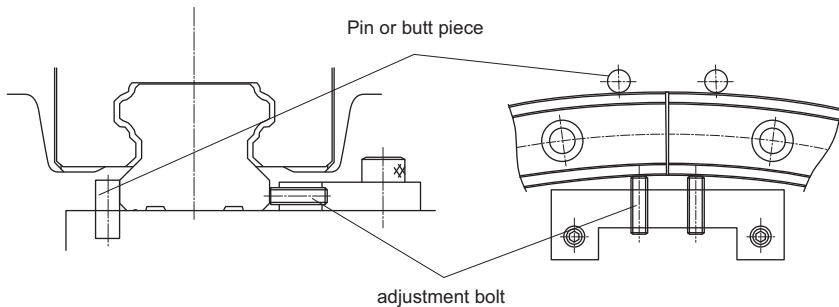

Fig.7 Flush piece

### [About the Curved Section]

The curved section of model HMG has a clearance for a structural reason. Therefore, this model may not be used in applications where highly accurate feed is required. In addition, the curved section cannot withstand a large moment. When a large moment is applied, it is necessary to increase the number of LM blocks or LM rails. For permissible moment values, see Table1 on **A1-345**.

### [Jointed LM Rail]

Model HMG always requires a jointed rail where an LM block travels from the straight section to the curved section and where the curve is inverted such as an S curve. Take this into account when design the system.

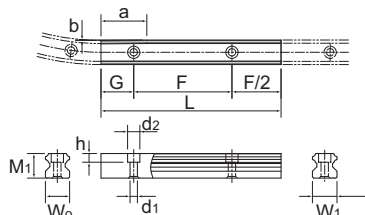

Table3 Dimension of the Jointed Rail

Unit: mm

Model No.	Dimension of the jointed rail							
	Height	Pitch	Mounting hole	Width		Taper length	Taper depth	Radius
	M <sub>1</sub>	F	d <sub>1</sub> ×d <sub>2</sub> ×h	W <sub>1</sub>	W <sub>0</sub>	a	b	R
15A	15	60	4.5×7.5×5.3	15	14.78	28	0.22	150
					14.89		0.11	300
					14.92		0.08	400
25A	22	60	7×11×9	23	22.83	42	0.17	500
					22.89		0.11	750
					22.92		0.08	1000
35A	29	80	9×14×12	34	33.77	54	0.23	600
					33.83		0.17	800
					33.86		0.14	1000
					33.9		0.1	1300
45A	38	105	14×20×17	45	44.71	76	0.29	800
					44.77		0.23	1000
					44.81		0.19	1200
					44.86		0.14	1600
65A	53	150	18×26×22	63	62.48	107	0.52	1000
					62.66		0.34	1500
					62.74		0.26	2000
					62.8		0.2	2500
					62.83		0.17	3000

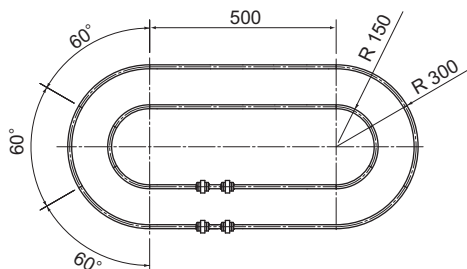

Fig.8 Example of model No.

## Model number coding

When 2 rails are used						
<b>HMG15A</b>	<b>2</b>	<b>UU</b>	<b>C1</b>	<b>+1000L</b>	<b>T</b>	<b>+ 60/150R 6T + 60/300R 6T - II</b>
Model number	Contamination protection accessory symbol (*1)	Overall linear LM rail length per rail	Center angle of one inner curved rail	No. of inner curved LM rails jointed	Radius of outer curved rail	Symbol for No. of rails used on the same plane (*2)
No. of LM blocks used on the same rail	Radial clearance symbol Normal (No symbol) Light preload (C1)	Symbol for linear LM rail joint	Radius of inner curved rail	Center angle of one outer curved rail	No. of outer curved LM rails jointed	

(\*1) See contamination protection accessory on **A1-524**. (\*2) See **A1-13**.

Note) This model number indicates that an LM block and an LM rail constitute one set (i.e., the required number of sets when 2 rails are used is 2).

The standard Model HMG does not have a seal. To attach a seal, make sure to specify a straight-curved seal (code: UU). For the model number above, use Fig.8.