

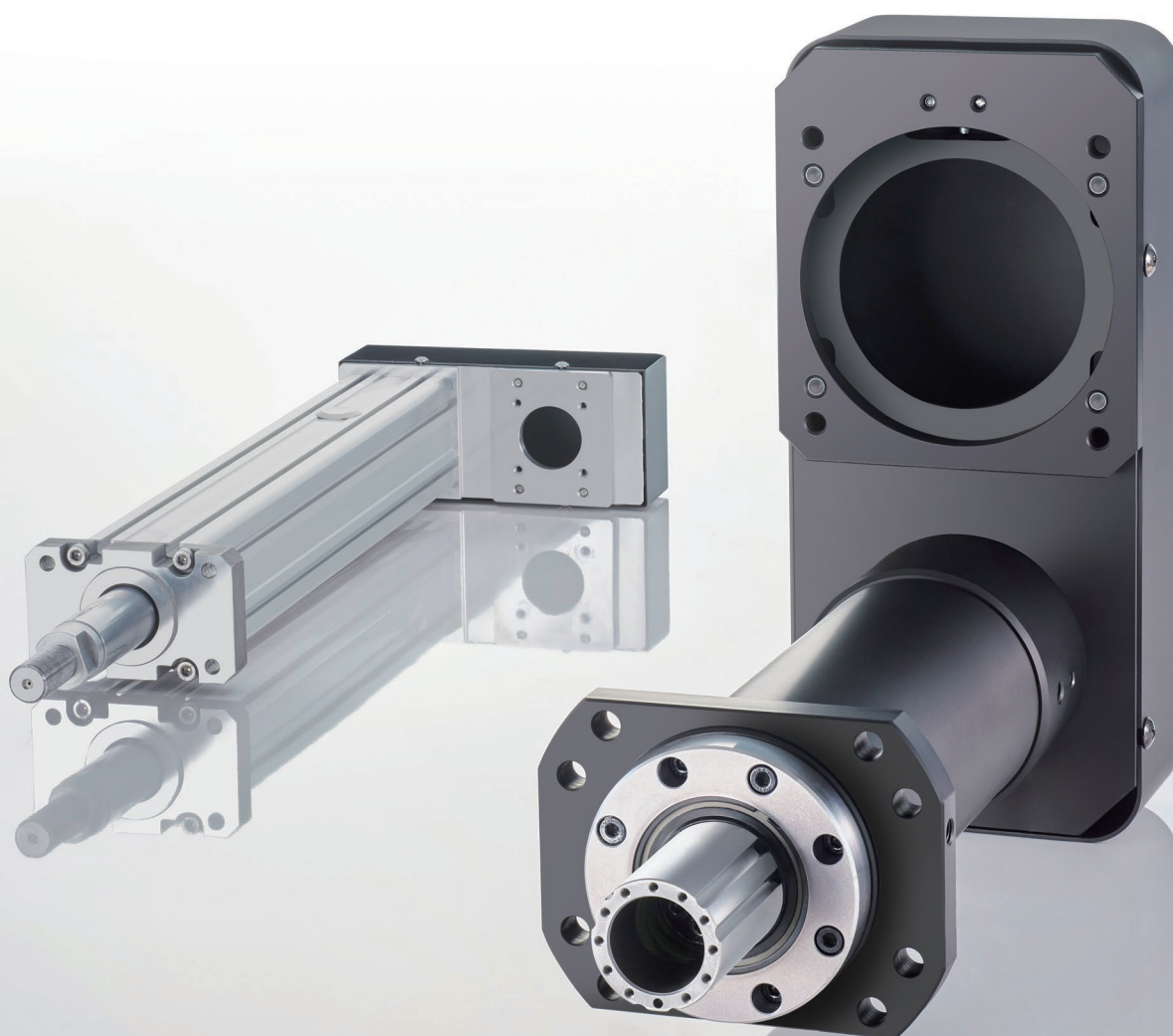

Electric Cylinder **PC/PCT**



Maximum instantaneous thrust of 250 kN.  
Smooth motion and highly precise positioning repeatability.  
Compact design.

High  
efficiency



Low running  
cost

---

Motorization for numerous press processes

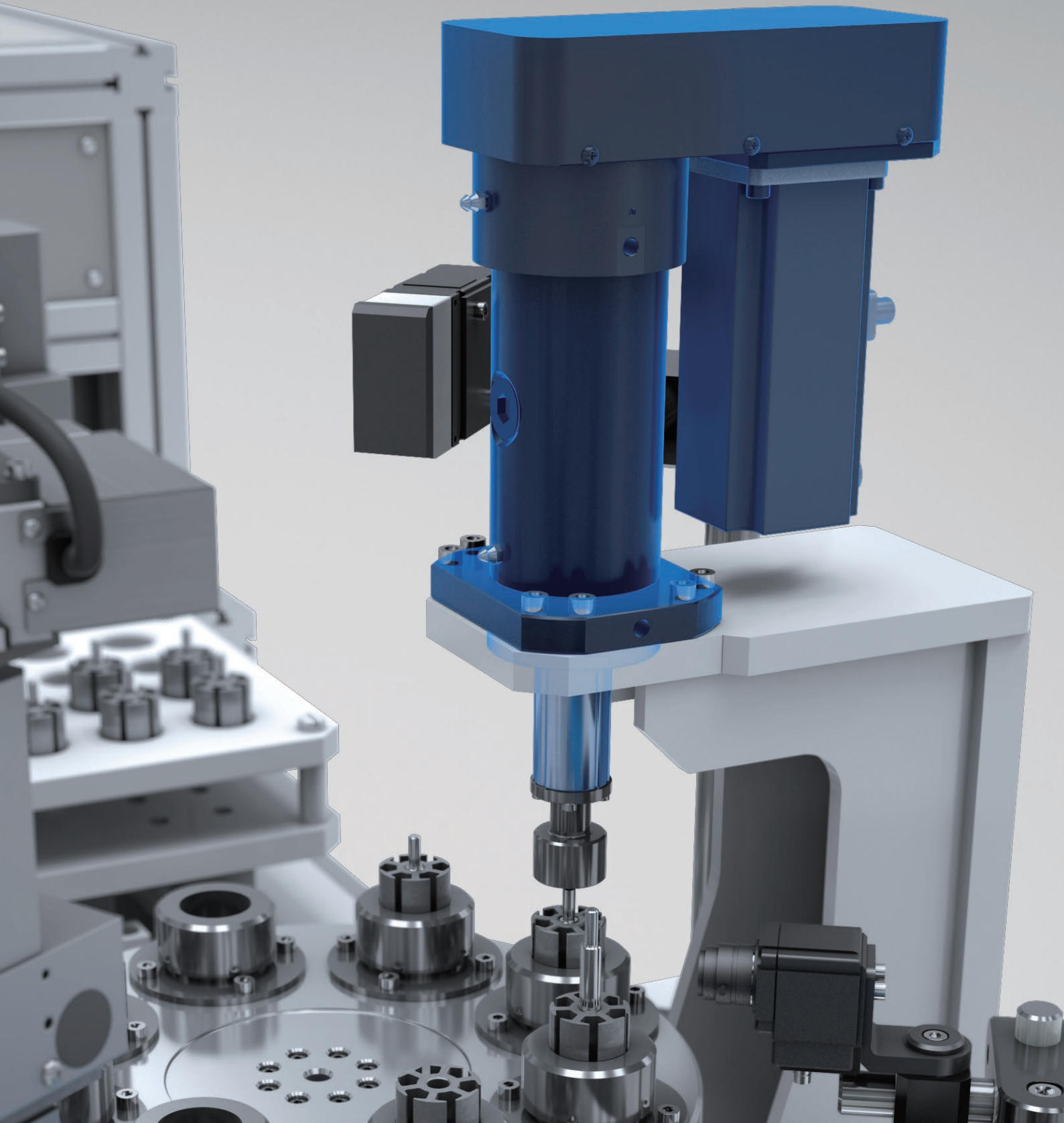

# Electric Cylinder

Motorization of the cylinder driver provides five benefits.

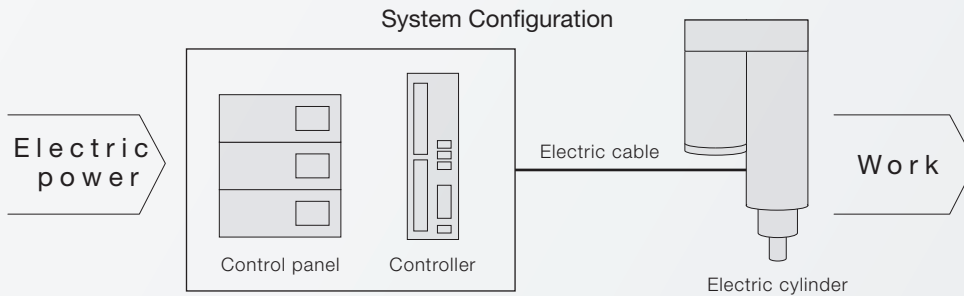
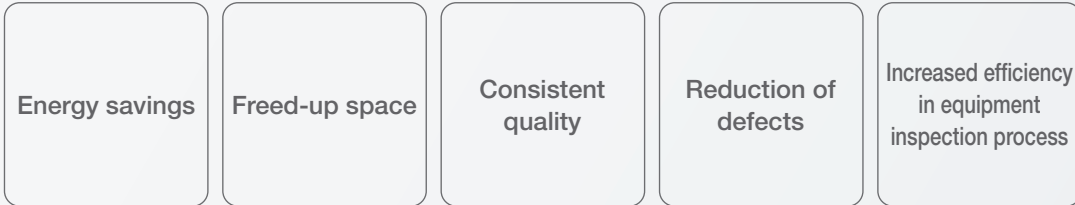

(Example) Electric and Hydraulic Cylinder Comparison

	Motion control				Machining control			Environment		
Electric	○	○	○	○	○	○	○	○	○	○
Properties	Ability to select speed	High-speed motion	Ability to select thrust	Bottom dead center position control when molding	High-precision machining	Ability to machine difficult materials	Lower burden on molds	Compact equipment footprint	Clean environment	Quiet noise
Hydraulic	○	○	○	-	-	○	-	-	-	-

<sup>1</sup> The above is a general comparison.

<sup>2</sup> ◎: Superior, ○: Good, -: Not compatible

# Hydraulic Cylinder

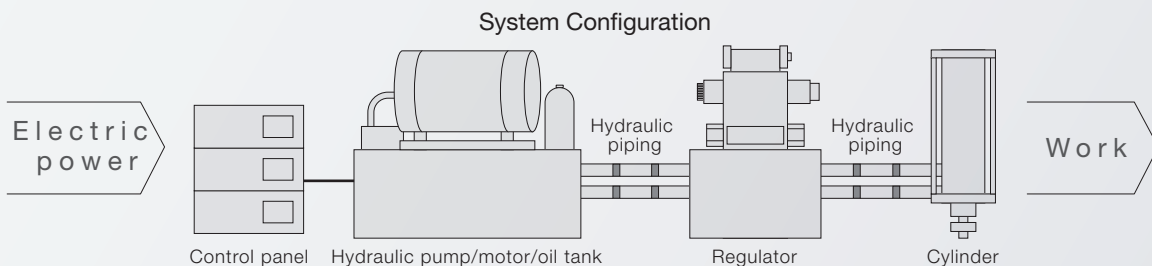
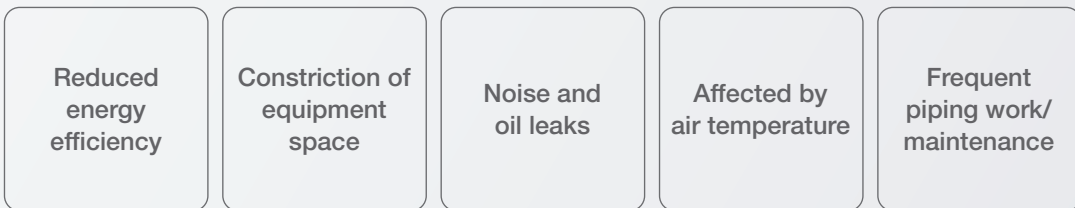

# Electric Cylinder PC/PCT

Achieves steady, high thrust and high-precision positioning repeatability by using a ball screw for the drive element.

## PC

High-thrust electric cylinder with proprietary, built-in mechanism combining the drive and guide elements

Compact, highly rigid, high-precision.  
Can be used in presses that require high thrust.

Space savings are enabled by the compact structure, which combines the ball spline shaft and the high-precision ball screw nut. Furthermore, this product achieves high thrust with a maximum instantaneous thrust of 250 kN\* and high-precision positioning repeatability.

It is optimal for high-precision pressing, press-fitting workpieces, punching, and deep drawing.

Smooth movement and high-precision positioning repeatability provided by ball spline and ball screw.

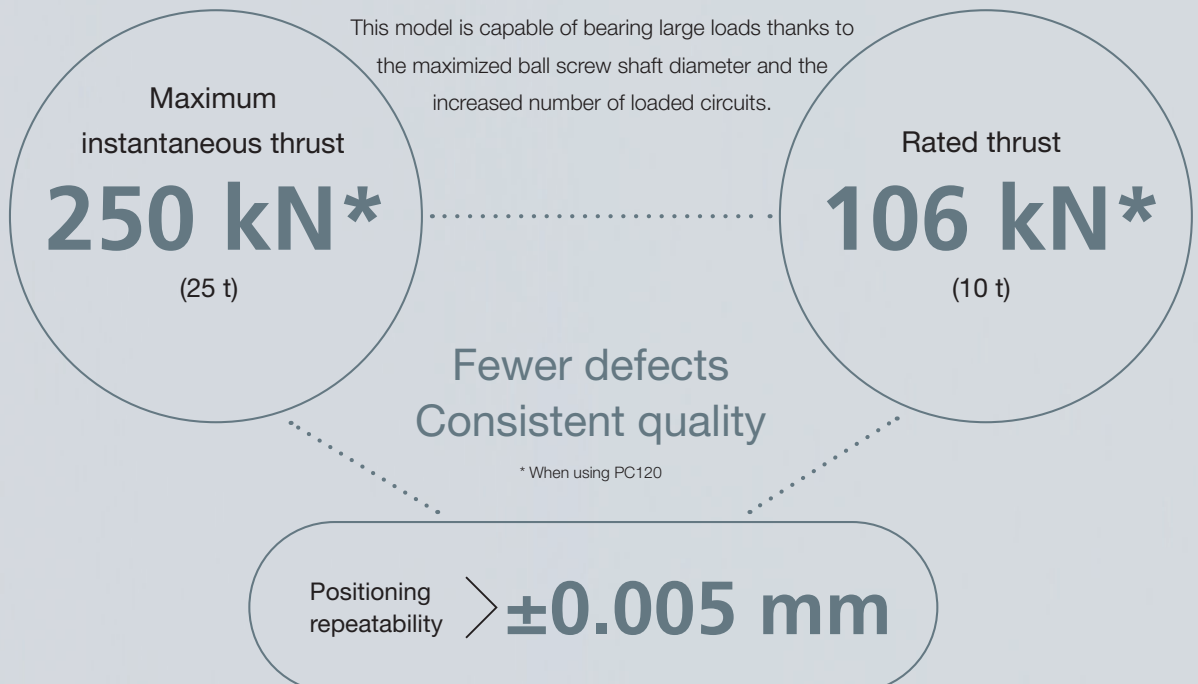

# PCT

An electric cylinder  
with an internal ball screw

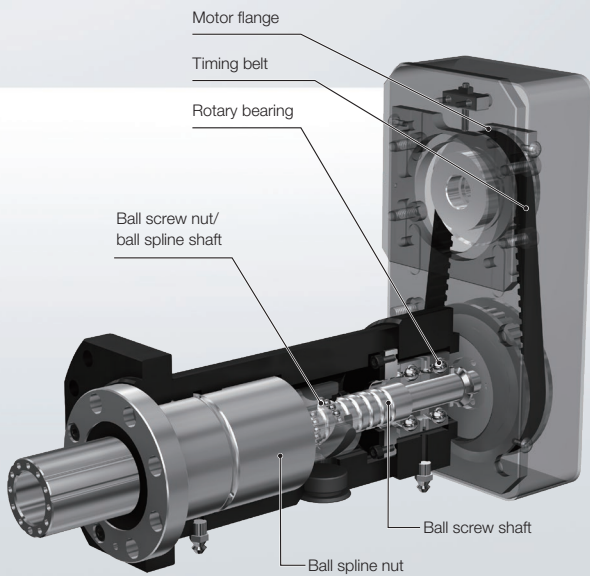

Unique, integrated structure enables compactness.

With an integrated structure combining a ball spline with a precision ball screw, the overall length is significantly more compact, and there are fewer components.

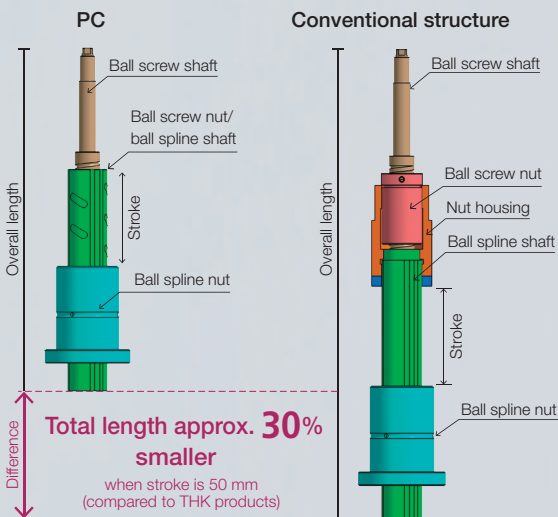

Supports a variety of mounting configurations with two different mounting methods.  
Enables high-precision positioning repeatability.

Because the PCT is specialized in rigidity for load-bearing in the axial direction, it can be used in small presses and caulking machines.

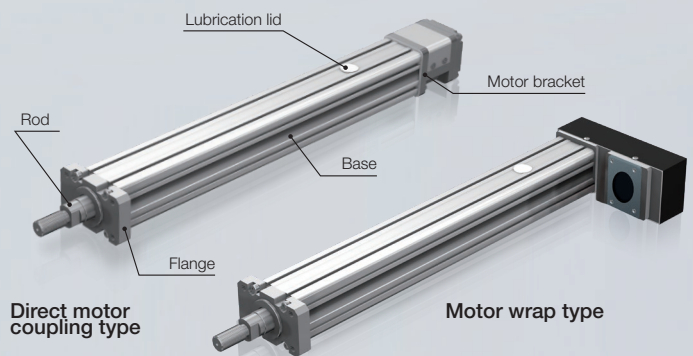

Rated thrust  
**800 N max.**

Positioning repeatability  $> \pm 0.01 \text{ mm}$

Mount with flange or mount using the T-slot on the main unit.

# APPLICATIONS

## PC

Press fitting

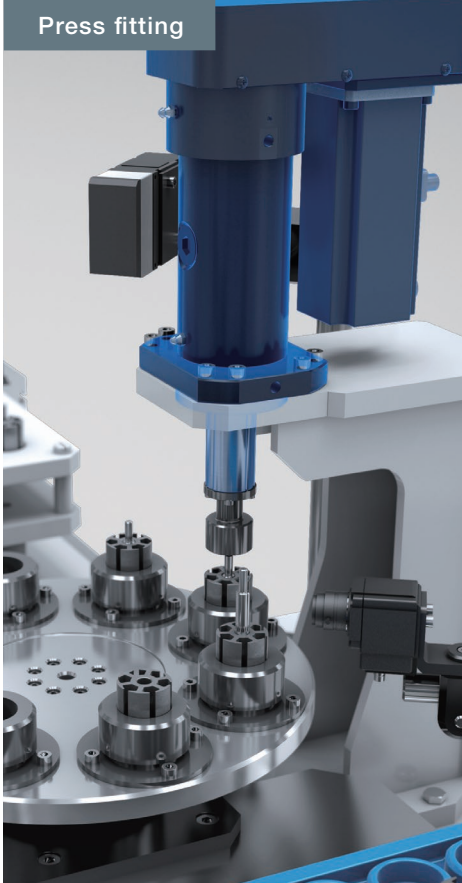

Punching

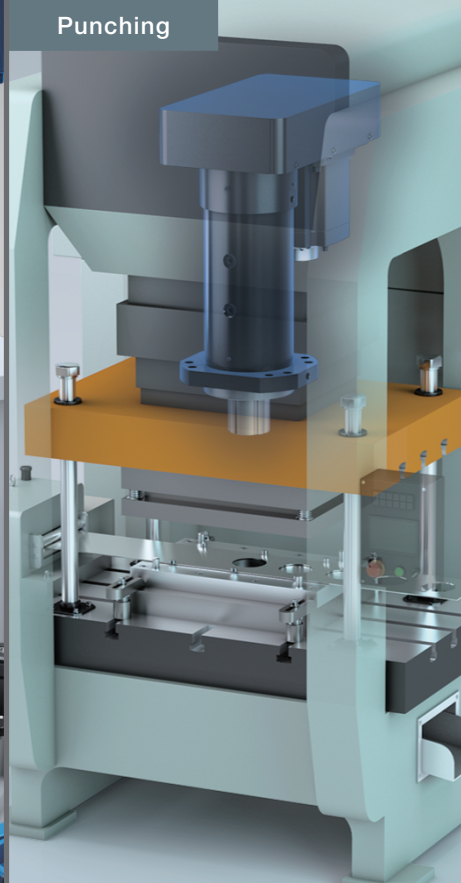

Deep drawing

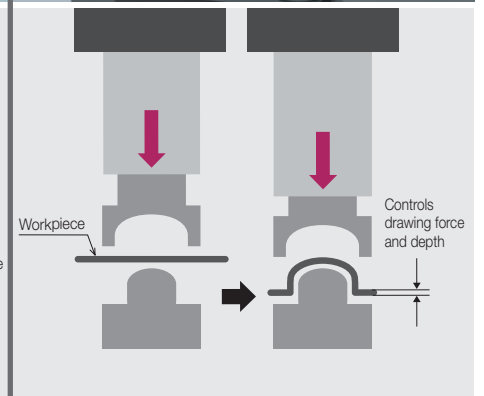
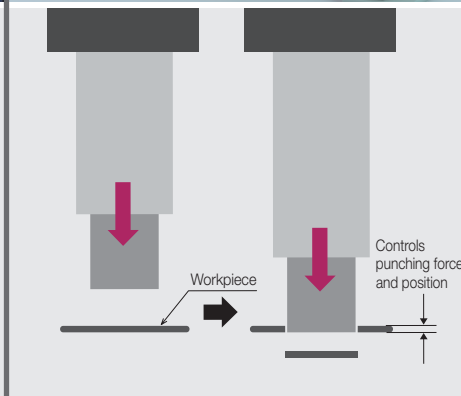
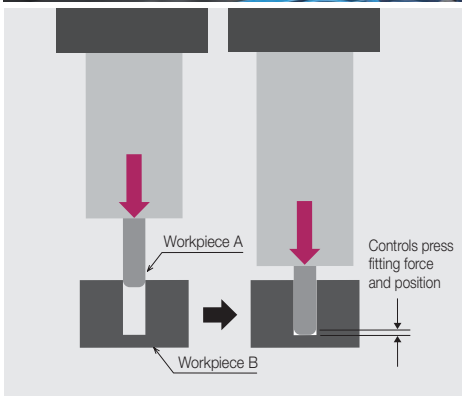
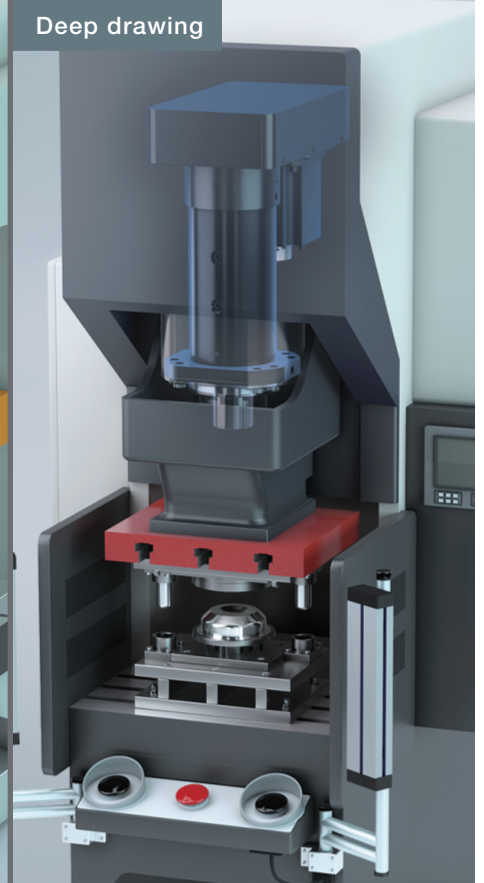

## PCT

Small-scale pressing

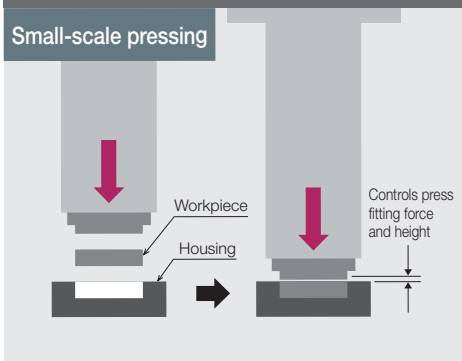

Caulking

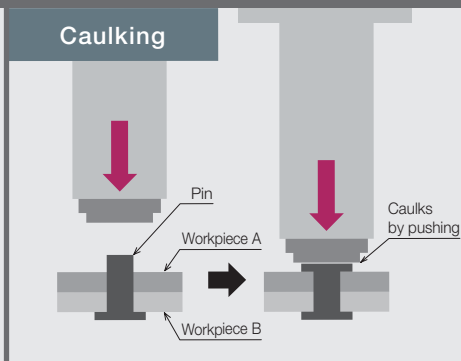

Binding

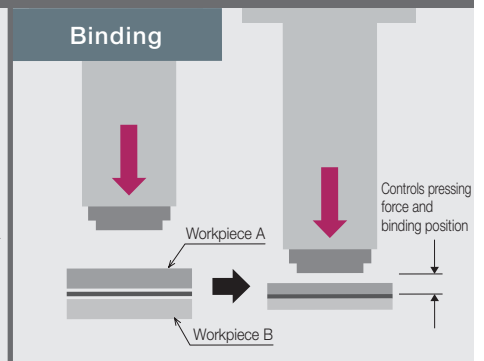

# Product Lineup

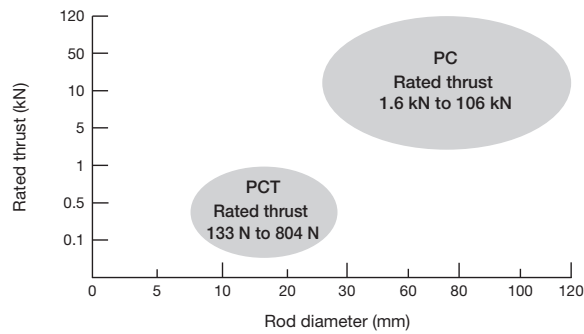

# Specifications

## PC

Model	Servo motor		Rated thrust <sup>1</sup> (kN)	Maximum instantaneous thrust <sup>2</sup> (kN)	Maximum speed <sup>3</sup> (mm/s)	Maximum stroke (mm)	Generated thrust <sup>4</sup> (kN)															
	Manufacturer	Estimated capacity (kW)					0	1	2	3	7.5	10	15	20	30	40	50	70	100	120	140	160
PC30-06A	Mitsubishi Electric Corporation	0.4 (0.36) <sup>5</sup>	1.6 (1.4) <sup>5</sup>	5.3	210	250																
	YASKAWA Electric Corporation																					
	SANYO DENKI CO., LTD.																					
	OMRON Corporation																					
PC40-06B	Mitsubishi Electric Corporation	0.75	3.2	10.1	200	250																
	YASKAWA Electric Corporation																					
	SANYO DENKI CO., LTD.																					
	OMRON Corporation																					
PC40H-08C	Mitsubishi Electric Corporation	1	5.6	15.5	151	250																
	YASKAWA Electric Corporation																					
	SANYO DENKI CO., LTD.																					
	OMRON Corporation																					
PC50-06D	Mitsubishi Electric Corporation	1.5	8.4	22.4	150	250																
	YASKAWA Electric Corporation																					
	SANYO DENKI CO., LTD.																					
	OMRON Corporation																					
PC60-10E	Mitsubishi Electric Corporation	2	10.9	31.1	155	250																
	YASKAWA Electric Corporation																					
	SANYO DENKI CO., LTD.																					
	OMRON Corporation																					
PC60H-10F	Mitsubishi Electric Corporation	3.5	17.8	35.6	166	250																
	YASKAWA Electric Corporation																					
	SANYO DENKI CO., LTD.																					
	OMRON Corporation																					
PC80L-12G	Mitsubishi Electric Corporation	5	23.9	71.6	177	250																
	YASKAWA Electric Corporation																					
	SANYO DENKI CO., LTD.																					
	OMRON Corporation																					
PC80-12G	Mitsubishi Electric Corporation	5.5	35	102	133	250																
	YASKAWA Electric Corporation																					
	SANYO DENKI CO., LTD.																					
	OMRON Corporation																					
PC80H-12G	Mitsubishi Electric Corporation	7.5	47.8	119	133	250																
	YASKAWA Electric Corporation																					
	SANYO DENKI CO., LTD.																					
	OMRON Corporation																					
PC100-20H	Mitsubishi Electric Corporation	11	70	175	125	400																
	YASKAWA Electric Corporation																					
	SANYO DENKI CO., LTD.																					
	OMRON Corporation																					
PC120-20J	Mitsubishi Electric Corporation	15	106	250	112	400																
	YASKAWA Electric Corporation																					
	SANYO DENKI CO., LTD.																					
	OMRON Corporation																					

■ Rated thrust / ■ Maximum instantaneous thrust

<sup>1</sup> The rated thrust refers to the thrust force at the rated motor torque for the estimated motor capacity.

<sup>2</sup> Maximum instantaneous thrust is limited by the permissible axial load.

<sup>3</sup> The maximum speed is restricted either by the rated rotational speed for the estimated motor capacity or by the permissible speed of the actuator.

<sup>4</sup> Contact THK if the product will be used for pressing motions above the rated thrust but below the maximum instantaneous thrust.

<sup>5</sup> Value within parentheses is when a SANYO DENKI CO., LTD. motor with a brake is used.

## PCT

Model	Estimated motor capacity (W)	Rated thrust <sup>5</sup> (N)	Maximum speed <sup>7</sup> (mm/s)	Maximum stroke (mm)	Generated thrust <sup>8</sup> (N)						
					0	100	250	500	1,000	1,500	2,500
PCT20-06N	50	133	300	200							
PCT20R-06N											
PCT25-06N	100	266	300	300							
PCT25R-06N											
PCT25-04N		400	200								
PCT25R-04N											
PCT25-06N	200	536	300	300							
PCT25R-06N											
PCT25-04N		804	200								
PCT25R-04N											

■ Rated thrust / ■ Maximum instantaneous thrust

<sup>6</sup> The rated thrust refers to the thrust force at the rated motor torque for the estimated motor capacity.

<sup>7</sup> The maximum speed is restricted either by the rotational speed of the motor at 3000 min<sup>-1</sup> or by the permissible speed of the actuator.

<sup>8</sup> Contact THK if the product will be used for pressing motions above the rated thrust but below the maximum instantaneous thrust.

Note: See the page of each model for details concerning specifications.

# PC Model Number Coding

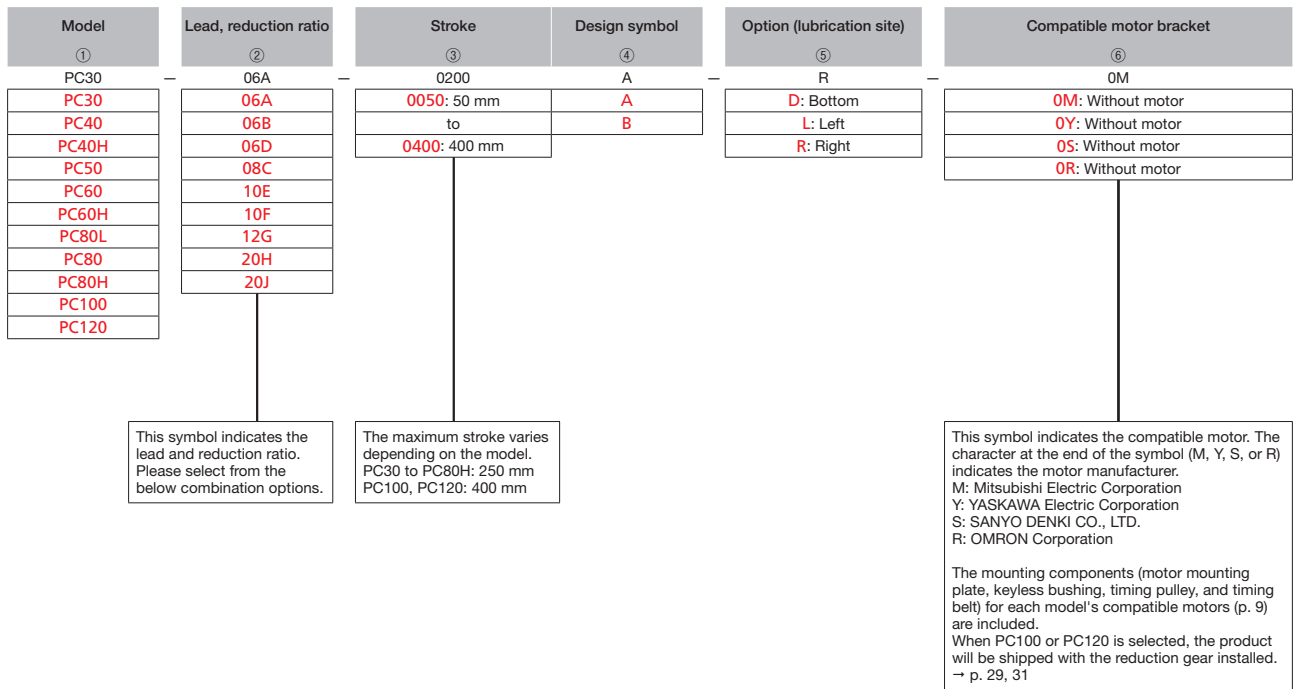

## Combination Options

Model ①	Lead, reduction ratio ②	Stroke ③	Design symbol ④
PC30	06A	0050 to 0250	B
PC40	06B		
PC40H	08C		
PC50	06D		
PC60	10E		
PC60H	10F		
PC80L	12G		
PC80			
PC80H			
PC100	20H	0200, 0400	A
PC120	20J		

# PCT Model Number Coding

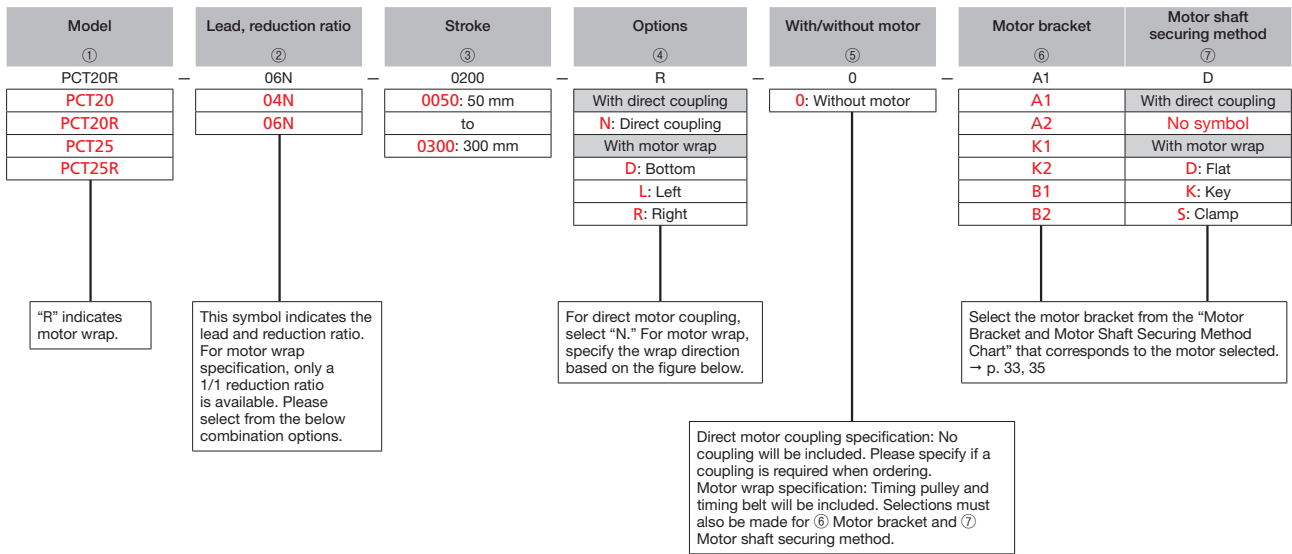

## Combination Options

Model ①	Lead, reduction ratio ②	Stroke ③
PCT20 PCT20R	06N	0050 to 0200
PCT25 PCT25R	06N or 04N	0050 to 0300

### ④ Option (Motor Wrap)

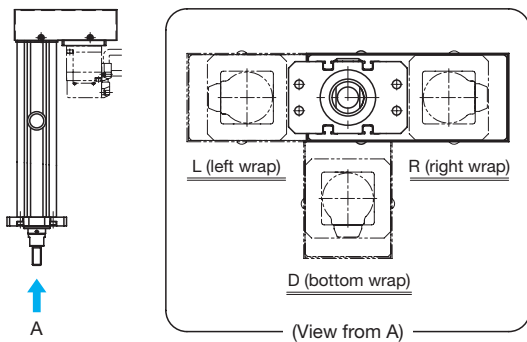

## Compatible Motors (Control Devices) by Model List

Model, lead, reduction ratio	Manufacturer		Motor model	Motor rated output (kW)	Compatible motor bracket <sup>1</sup>
PC30-06A	Mitsubishi Electric Corporation	Without brake	HG-KR43	0.4	0M
		With brake	HG-KR43B		
		Without brake	HK-KT43W		
		With brake	HK-KT43WB		
	YASKAWA Electric Corporation	Without brake	SGM7J-04AFA21	0.4	0Y
		With brake	SGM7J-04AFA2C		
		Without brake	SGMXJ-04AWA21A1		
		With brake	SGMXJ-04AWA2CA1		
	SANYO DENKI CO., LTD.	Without brake	R2AA06040FXRA0M	0.4	0S
		With brake	R2AA06040FCRA0M6		
	OMRON Corporation	Without brake	R88M-K40030T	0.4	0R
		With brake	R88M-K40030T-B		
Without brake		R88M-1M40030T			
With brake		R88M-1M40030T-B			
PC40-06B	Mitsubishi Electric Corporation	Without brake	HG-KR73	0.75	0M
		With brake	HG-KR73B		
		Without brake	HK-KT7M3W		
		With brake	HK-KT7M3WB		
	YASKAWA Electric Corporation	Without brake	SGM7J-08AFA21	0.75	0Y
		With brake	SGM7J-08AFA2C		
		Without brake	SGMXJ-08AWA21A1		
		With brake	SGMXJ-08AWA2CA1		
	SANYO DENKI CO., LTD.	Without brake	R2AA08075FXRA0M	0.75	0S
		With brake	R2AA08075FCRA0M		
	OMRON Corporation	Without brake	R88M-K75030T	0.75	0R
		With brake	R88M-K75030T-B		
Without brake		R88M-1M75030T			
With brake		R88M-1M75030T-B			
PC40H-08C	Mitsubishi Electric Corporation	Without brake	HG-SR102	1	0M
		With brake	HG-SR102B		
		Without brake	HK-ST102W		
		With brake	HK-ST102WB		
	YASKAWA Electric Corporation	Without brake	SGM7G-09AFA21	0.85	0Y
		With brake	SGM7G-09AFA2C		
		Without brake	SGMXG-09AWA21A1		
		With brake	SGMXG-09AWA2CA1		
	SANYO DENKI CO., LTD.	Without brake	R2AA13120BXCRC0 <sup>2</sup>	1.2	0S
		With brake	R2AA13120BCRC0 <sup>2</sup>		
	OMRON Corporation	Without brake	R88M-K1K020T	1	0R
		With brake	R88M-K1K020T-B		
Without brake		R88M-1M1K020T			
With brake		R88M-1M1K020T-B			
PC50-06D	Mitsubishi Electric Corporation	Without brake	HG-SR152	1.5	0M
		With brake	HG-SR152B		
		Without brake	HK-ST172W		
		With brake	HK-ST172WB		
	YASKAWA Electric Corporation	Without brake	SGM7G-13AFA21	1.3	0Y
		With brake	SGM7G-13AFA2C		
		Without brake	SGMXG-13AWA21A1		
		With brake	SGMXG-13AWA2CA1		
	SANYO DENKI CO., LTD.	Without brake	R2AA13180HXCRC0 <sup>2</sup>	1.8	0S
		With brake	R2AA13180HCRC0 <sup>2</sup>		
	OMRON Corporation	Without brake	R88M-K1K520T	1.5	0R
		With brake	R88M-K1K520T-B		
Without brake		R88M-1M1K520T			
With brake		R88M-1M1K520T-B			
PC60-10E	Mitsubishi Electric Corporation	Without brake	HG-SR202	2	0M
		With brake	HG-SR202B		
		Without brake	HK-ST202W		
		With brake	HK-ST202WB		
	YASKAWA Electric Corporation	Without brake	SGM7G-20AFA21	1.8	0Y
		With brake	SGM7G-20AFA2C		
		Without brake	SGMXG-20AWA21A1		
		With brake	SGMXG-20AWA2CA1		
	SANYO DENKI CO., LTD.	Without brake	R2AA13200LXCRC0 <sup>2</sup>	2	0S
		With brake	R2AA13200LCRC0 <sup>2</sup>		
	OMRON Corporation	Without brake	R88M-K2K020T	2	0R
		With brake	R88M-K2K020T-B		
Without brake		R88M-1M2K020T			
With brake		R88M-1M2K020T-B			

<sup>1</sup>The character at the end of the symbol (M, Y, S, or R) represents the motor manufacturer. M: Mitsubishi Electric Corporation; Y: YASKAWA Electric Corporation; S: SANYO DENKI CO., LTD.; R: OMRON Corporation

<sup>2</sup>Special product for PC specification.

Note: The table shows only a portion of the model numbers for motors. For details regarding model numbers, please see the catalog for each respective motor manufacturer.

Model, lead, reduction ratio	Manufacturer		Motor model	Motor rated output (kW)	Compatible motor bracket <sup>1</sup>
PC60H-10F	Mitsubishi Electric Corporation	Without brake	HG-SR352	3.5	0M
		With brake	HG-SR352B		
		Without brake	HK-ST352W		
		With brake	HK-ST352WB		
	YASKAWA Electric Corporation	Without brake	SGM7G-30AFA21	2.9	0Y
		With brake	SGM7G-30AFA2C		
		Without brake	SGMXG-30AWA81A1		
		With brake	SGMXG-30AWA8CA1		
	SANYO DENKI CO., LTD.	Without brake	R2AA18350LXRC0 <sup>2</sup>	3.5	0S
		With brake	R2AA18350LCRC0 <sup>2</sup>		
	OMRON Corporation	Without brake	R88M-K4K020T	4	0R
		With brake	R88M-K4K020T-B		
Without brake		R88M-1M4K015T			
With brake		R88M-1M4K015T-B			
PC80L-12G	Mitsubishi Electric Corporation	Without brake	HG-SR502	5	0M
		With brake	HG-SR502B		
		Without brake	HK-ST502W		
		With brake	HK-ST502WB		
	YASKAWA Electric Corporation	Without brake	SGM7G-44AFA21	4.4	0Y
		With brake	SGM7G-44AFA2C		
		Without brake	SGMXG-44AWA81A1		
		With brake	SGMXG-44AWA8CA1		
	SANYO DENKI CO., LTD.	Without brake	R2AA18450HXRC0 <sup>2</sup>	4.5	0S
		With brake	R2AA18450HCRC0 <sup>2</sup>		
	OMRON Corporation	Without brake	R88M-K5K020T	5	0R
		With brake	R88M-K5K020T-B		
Without brake		R88M-1M4K015T	4	0R	
With brake		R88M-1M4K015T-B			
PC80-12G	Mitsubishi Electric Corporation	Without brake	HG-SR702	7	0M
		With brake	HG-SR702B		
		Without brake	HK-ST702W		
		With brake	HK-ST702WB		
	YASKAWA Electric Corporation	Without brake	SGM7G-55AFA21	5.5	0Y
		With brake	SGM7G-55AFA2C		
		Without brake	SGMXG-55AWA81A1		
		With brake	SGMXG-55AWA8CA1		
	SANYO DENKI CO., LTD.	Without brake	R2AA18550HXRC0 <sup>2</sup>	5.5	0S
		With brake	R2AA18550HCRC0 <sup>2</sup>		
	OMRON Corporation	Without brake	R88M-K4K510T	4.5	0R
		With brake	R88M-K4K510T-B		
Without brake		R88M-1M5K015T	5	0R	
With brake		R88M-1M5K015T-B			
PC80H-12G	Mitsubishi Electric Corporation	Without brake	HG-SR421	4.2	0M
		With brake	HG-SR421B		
		Without brake	HK-ST7024W		
		With brake	HK-ST7024WB		
	YASKAWA Electric Corporation	Without brake	SGM7G-75AFA21	7.5	0Y
		With brake	SGM7G-75AFA2C		
		Without brake	SGMXG-75AWA81A1		
		With brake	SGMXG-75AWA8CA1		
	SANYO DENKI CO., LTD.	Without brake	R2AA18750HXRC0 <sup>2</sup>	7.5	0S
		With brake	R2AA18750HCRC0 <sup>2</sup>		
	OMRON Corporation	Without brake	R88M-K7K515T	7.5	0R
		With brake	R88M-K7K515T-B		
Without brake		R88M-1M7K515T	7.5	0R	
With brake		R88M-1M7K515T-B			
PC100-20H	Mitsubishi Electric Corporation	Without brake	HG-JR11K1M	11	0M
		With brake	HG-JR11K1MB		
	YASKAWA Electric Corporation	Without brake	SGM7G-1AAFA21	11	0Y
		With brake	SGM7G-1AAFA2C		
		Without brake	SGMXG-1AAWA81A1		
		With brake	SGMXG-1AAWA8CA1		
	SANYO DENKI CO., LTD.	Without brake	R2AA2211KBXRC0 <sup>2</sup>	11	0S
		With brake	R2AA2211KBXRC0 <sup>2</sup>		
	OMRON Corporation	Without brake	R88M-K11K015T	11	0R
		With brake	R88M-K11K015T-B		
		Without brake	R88M-1M11K015T	11	0R
		With brake	R88M-1M11K015T-B		
PC120-20J	Mitsubishi Electric Corporation	Without brake	HG-JR15K1M	15	0M
		With brake	HG-JR15K1MB		
	YASKAWA Electric Corporation	Without brake	SGM7G-1EFA21	15	0Y
		With brake	SGM7G-1EFA2C		
		Without brake	SGMXG-1EAWA81A1		
		With brake	SGMXG-1EAWA8CA1		
	SANYO DENKI CO., LTD.	Without brake	R2AA2215KBXRC0 <sup>2</sup>	15	0S
		With brake	R2AA2215KBXRC0 <sup>2</sup>		
	OMRON Corporation	Without brake	R88M-K15K015T	15	0R
		With brake	R88M-K15K015T-B		
		Without brake	R88M-1M15K015T	15	0R
		With brake	R88M-1M15K015T-B		

<sup>1</sup> The character at the end of the symbol (M, Y, S, or R) represents the motor manufacturer. M: Mitsubishi Electric Corporation; Y: YASKAWA Electric Corporation; S: SANYO DENKI CO., LTD.; R: OMRON Corporation

<sup>2</sup> Special product for PC specification.

Note: The table shows only a portion of the model numbers for motors. For details regarding model numbers, please see the catalog for each respective motor manufacturer.

# PC30-06A

Rod diameter  
**30 mm**

Motor  
**wrap**

Max. stroke  
**250 mm**

## Model Number Coding

Model ①	Lead, reduction ratio ②	Stroke ③	Design symbol ④	Option (lubrication site) ⑤	Compatible motor bracket ⑥
PC30 <b>PC30</b>	06A <b>06A</b>	0200 <b>0050: 50 mm</b> to <b>0250: 250 mm</b>	B <b>B</b>	R <b>D: Bottom</b> <b>L: Left</b> <b>R: Right</b>	0M <b>0M: Without motor</b> <b>0Y: Without motor</b> <b>0S: Without motor</b> <b>0R: Without motor</b>

### Compatible Motor Bracket Symbol Coding

0	Y
Without motor	M: Mitsubishi Electric Corporation Y: YASKAWA Electric Corporation S: SANYO DENKI CO., LTD. R: OMRON Corporation

### ⑤ Option (lubrication site)

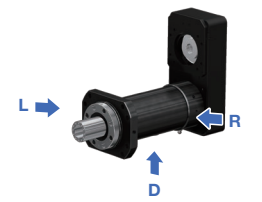
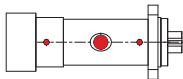
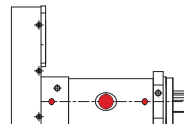
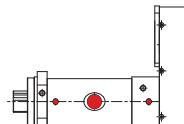
Lubrication site Symbol	Bottom D	Left L	Right R
Rough drawing of lubrication site 			

## Selection Information

### Basic Specifications<sup>1</sup>

Ball screw lead (mm)	6	
Reduction ratio	28/40	
Permissible axial load <sup>2</sup> (kN)	Pressing direction	5.3
	Pulling direction	1.6
Positioning repeatability (mm)	±0.005	
Backlash (mm)	0.02	
Permissible input torque <sup>3</sup> (N·m)	4.2	

- <sup>1</sup> The guideline value for the maximum acceleration/deceleration is 0.3 G.  
<sup>2</sup> The permissible axial load value shows the load that the product can bear while the actuator is stationary.  
<sup>3</sup> There is a risk of damage to the mechanical parts. Only use the motor within the permissible input torque range.  
 Note 1: Prepare a separate guide mechanism if a load will be applied to the rod in a non-axial direction.

### Theoretical Press Service Life (Press Cycles)

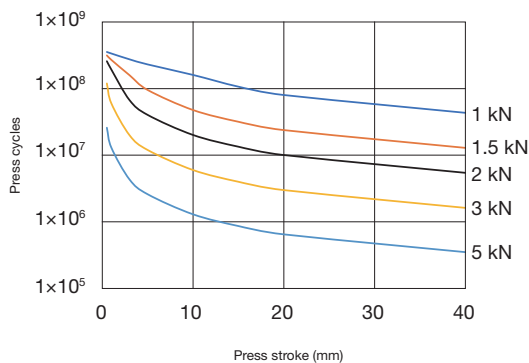

Service life will vary depending on press load and press stroke. Operating life values are theoretical based on the below conditions.  
 Mounting orientation: Vertical (rod facing down)  
 Pressing direction: Compression direction  
 Load mass: 15kg

Note 2: This graph is not a guarantee of press stroke operations under a press load.

### Maintenance

For greasing of the ball screw, remove the plug and apply grease directly to the ball screw shaft.  
 Lubricate the product with the rod extended to the lubrication site.

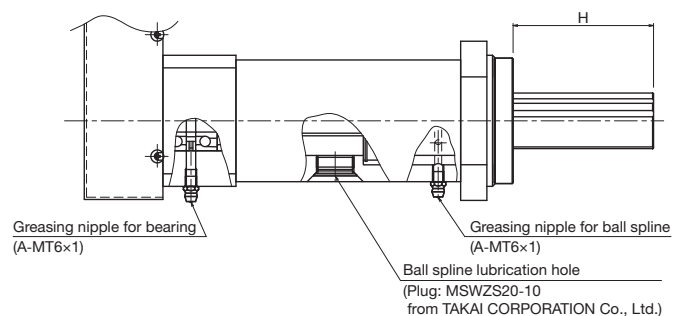

Stroke	50	100	150	200	250
Lubrication site: H	65	102	102	102	102

Unit: mm

# Dimensions

This figure shows lubrication site D (bottom).

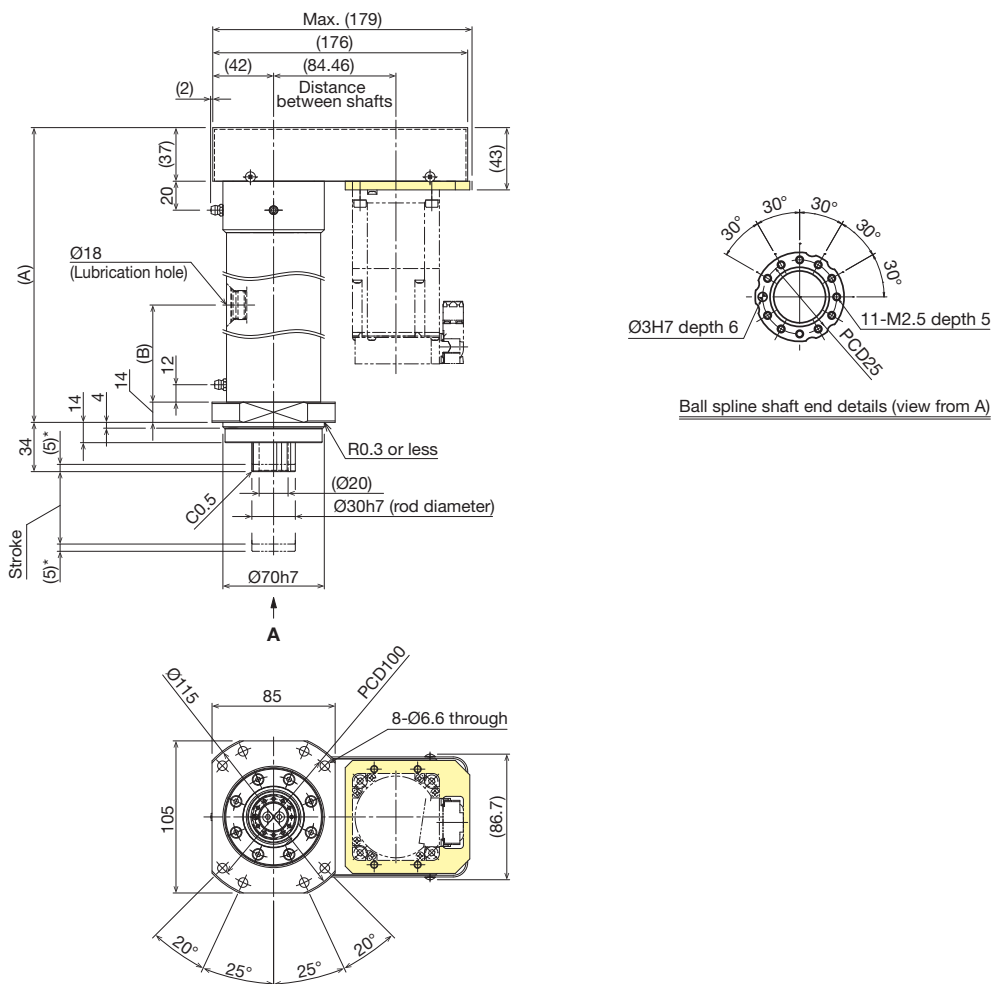

\* This is the stroke up to the mechanical stopper.

## Motor Attachment Details

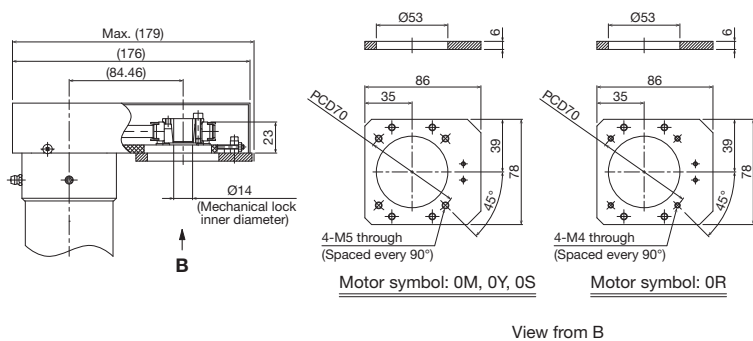

Stroke (mm) (Stroke between mechanical stoppers)	50 (60)	100 (110)	150 (160)	200 (210)	250 (260)
Dimensions (mm)					
A	203.5	253.5	303.5	353.5	403.5
B	67	80	130	180	230
Mass (kg)	6.9	8	9.2	10.3	11.4

# PC40-06B

Rod diameter  
**40 mm**

Motor  
**wrap**

Max. stroke  
**250 mm**

## Model Number Coding

Model ①	Lead, reduction ratio ②	Stroke ③	Design symbol ④	Option (lubrication site) ⑤	Compatible motor bracket ⑥
PC40 <b>PC40</b>	06B <b>06B</b>	0200 <b>0050: 50 mm</b> to <b>0250: 250 mm</b>	B <b>B</b>	R <b>D: Bottom</b> <b>L: Left</b> <b>R: Right</b>	0M <b>0M: Without motor</b> <b>0Y: Without motor</b> <b>0S: Without motor</b> <b>0R: Without motor</b>

### Compatible Motor Bracket Symbol Coding

0	Y
Without motor	M: Mitsubishi Electric Corporation Y: YASKAWA Electric Corporation S: SANYO DENKI CO., LTD. R: OMRON Corporation

### ⑤ Option (lubrication site)

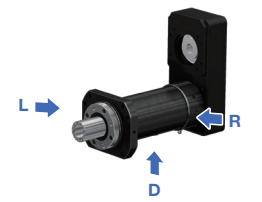
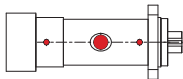
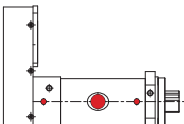
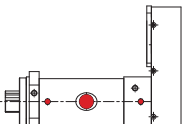
Lubrication site Symbol	Bottom D	Left L	Right R
Rough drawing of lubrication site 			

## Selection Information

### Basic Specifications<sup>1</sup>

Ball screw lead (mm)	6	
Reduction ratio	32/48	
Permissible axial load <sup>2</sup> (kN)	Pressing direction	10.1
	Pulling direction	3.2
Positioning repeatability (mm)	±0.005	
Backlash (mm)	0.02	
Permissible input torque <sup>3</sup> (N·m)	7.6	

<sup>1</sup> The guideline value for the maximum acceleration/deceleration is 0.3 G.

<sup>2</sup> The permissible axial load value shows the load that the product can bear while the actuator is stationary.

<sup>3</sup> There is a risk of damage to the mechanical parts. Only use the motor within the permissible input torque range.

Note 1: Prepare a separate guide mechanism if a load will be applied to the rod in a non-axial direction.

### Theoretical Press Service Life (Press Cycles)

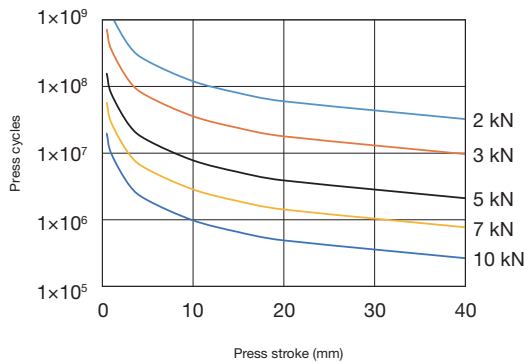

Service life will vary depending on press load and press stroke. Operating life values are theoretical based on the below conditions.

Mounting orientation: Vertical (rod facing down)  
Pressing direction: Compression direction  
Load mass: 25kg

Note 2: This graph is not a guarantee of press stroke operations under a press load.

### Maintenance

For greasing of the ball screw, remove the plug and apply grease directly to the ball screw shaft.

Lubricate the product with the rod extended to the lubrication site.

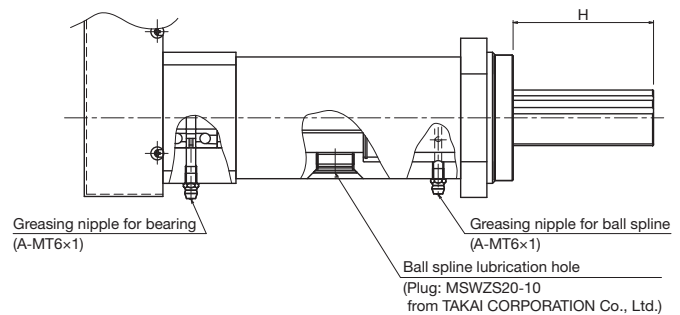

Stroke	50	100	150	200	250
Lubrication site: H	75	115	115	115	115

Unit: mm

# Dimensions

This figure shows lubrication site D (bottom).

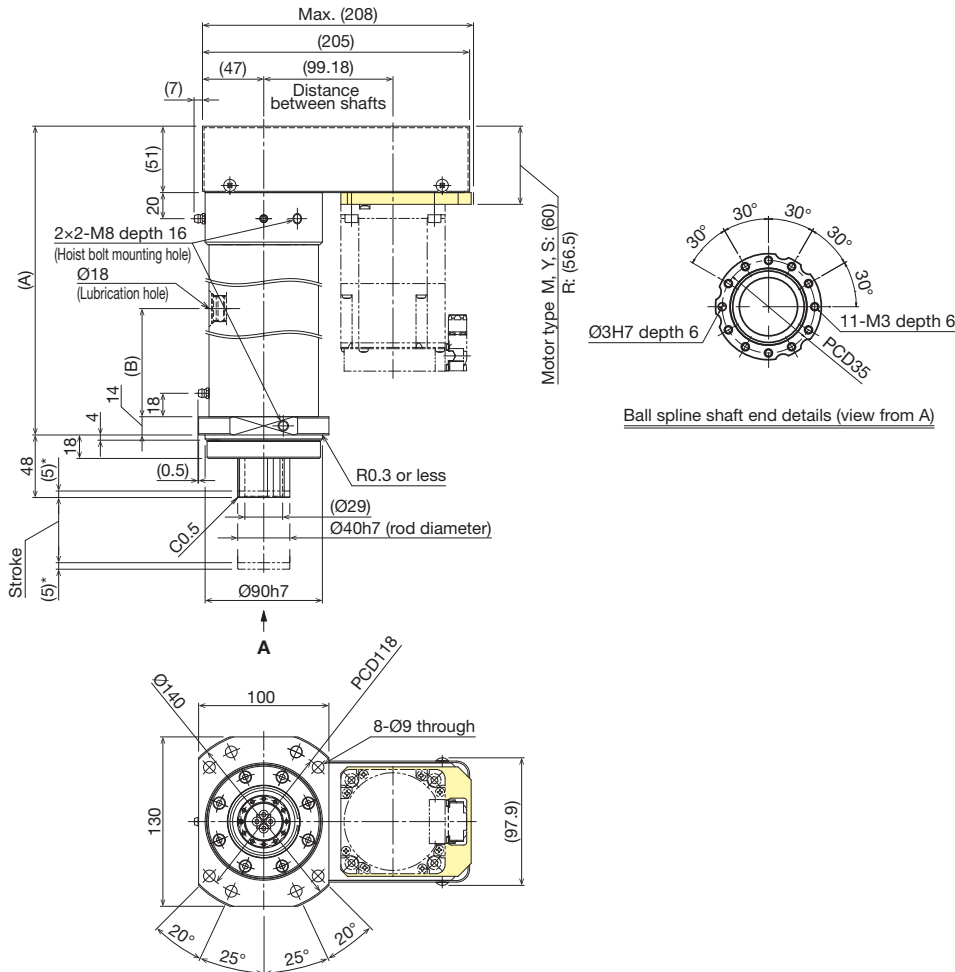

\* This is the stroke up to the mechanical stopper.

## Motor Attachment Details

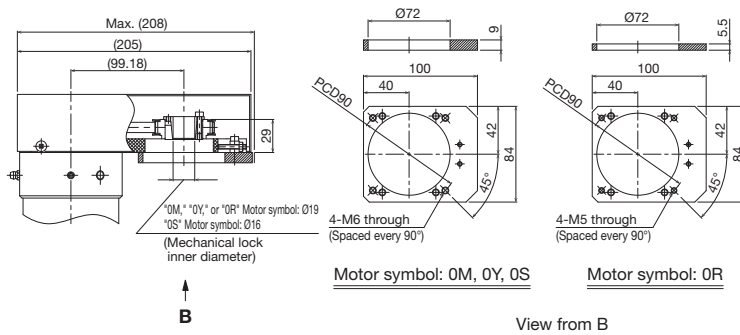

Stroke (mm) (Stroke between mechanical stoppers)	50 (60)	100 (110)	150 (160)	200 (210)	250 (260)
Dimensions (mm)					
A	237	287	337	387	437
B	83	93	143	193	243
Mass (kg)	12.3	13.9	15.5	17.1	18.7

# PC40H-08C

Rod diameter  
**40 mm**

Motor  
**wrap**

Max. stroke  
**250 mm**

## Model Number Coding

Model ①	Lead, reduction ratio ②	Stroke ③	Design symbol ④	Option (lubrication site) ⑤	Compatible motor bracket ⑥
PC40H <b>PC40H</b>	08C <b>08C</b>	0200 <b>0050: 50 mm</b> to <b>0250: 250 mm</b>	B <b>B</b>	R <b>D: Bottom</b> <b>L: Left</b> <b>R: Right</b>	0M <b>0M: Without motor</b> <b>0Y: Without motor</b> <b>0S: Without motor</b> <b>0R: Without motor</b>

### Compatible Motor Bracket Symbol Coding

0	Y
Without motor	M: Mitsubishi Electric Corporation Y: YASKAWA Electric Corporation S: SANYO DENKI CO., LTD. R: OMRON Corporation

### ⑤ Option (lubrication site)

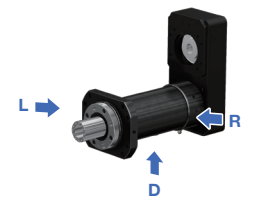
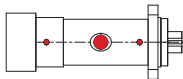
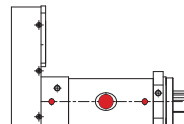
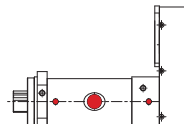
Lubrication site Symbol	Bottom D	Left L	Right R
Rough drawing of lubrication site 			

## Selection Information

### Basic Specifications<sup>1</sup>

Ball screw lead (mm)	8	
Reduction ratio	25/44	
Permissible axial load <sup>2</sup> (kN)	Pressing direction	15.5
	Pulling direction	5.6
Positioning repeatability (mm)	±0.005	
Backlash (mm)	0.02	
Permissible input torque <sup>3</sup> (N·m)	13.2	

<sup>1</sup> The guideline value for the maximum acceleration/deceleration is 0.1 G.

<sup>2</sup> The permissible axial load value shows the load that the product can bear while the actuator is stationary.

<sup>3</sup> There is a risk of damage to the mechanical parts. Only use the motor within the permissible input torque range.

Note 1: Prepare a separate guide mechanism if a load will be applied to the rod in a non-axial direction.

### Theoretical Press Service Life (Press Cycles)

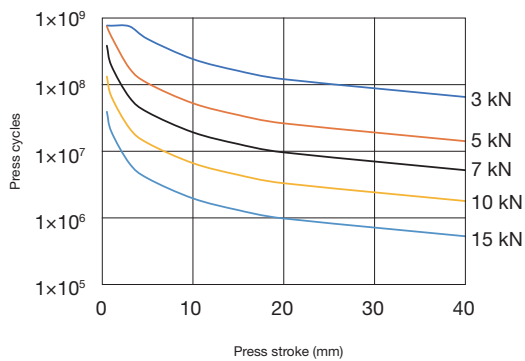

Service life will vary depending on press load and press stroke. Operating life values are theoretical based on the below conditions.

Mounting orientation: Vertical (rod facing down)  
Pressing direction: Compression direction  
Load mass: 50kg

Note 2: This graph is not a guarantee of press stroke operations under a press load.

### Maintenance

For greasing of the ball screw, remove the plug and apply grease directly to the ball screw shaft.

Lubricate the product with the rod extended to the lubrication site.

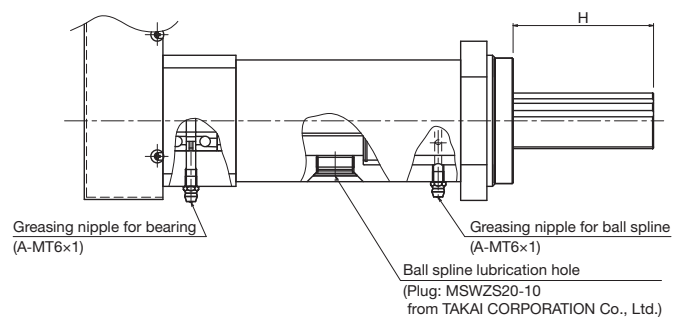

Stroke	50	100	150	200	250
Lubrication site: H	78	118	148	148	148

Unit: mm

# Dimensions

This figure shows lubrication site D (bottom).

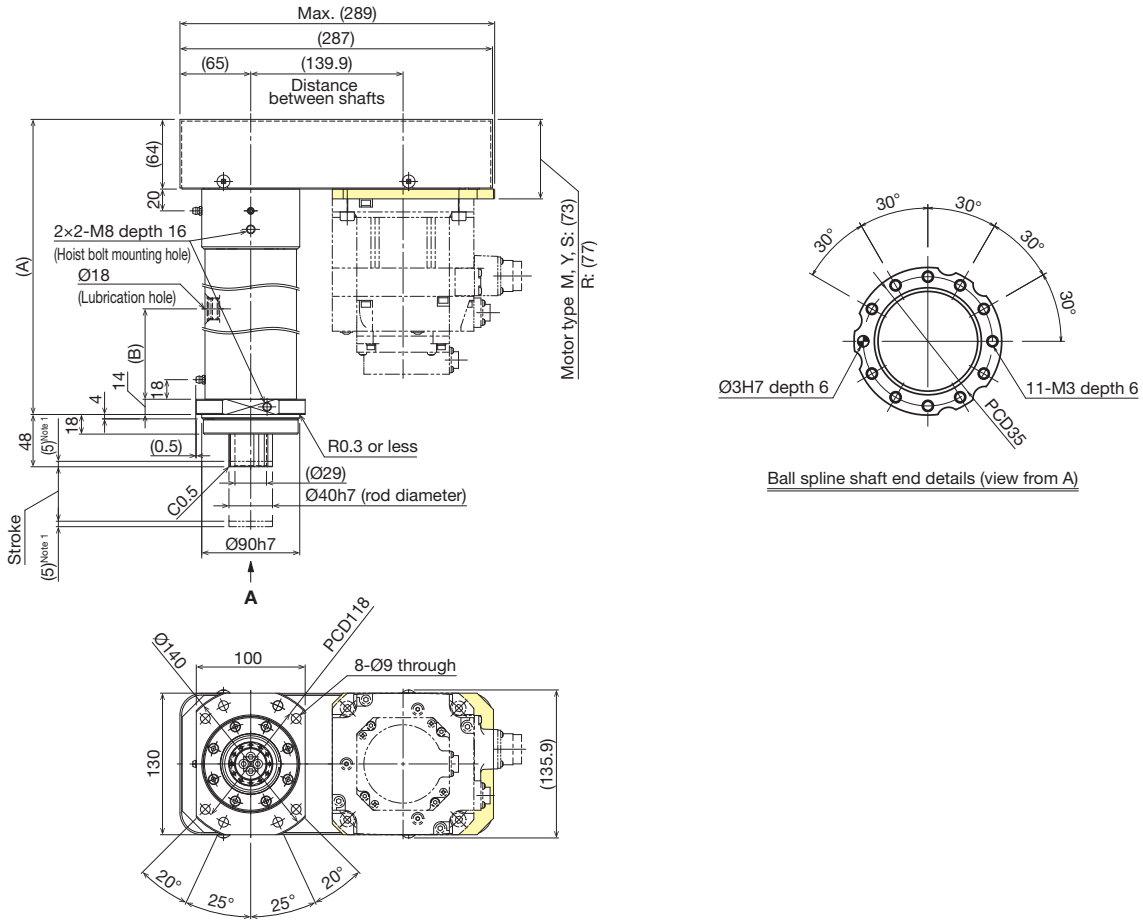

<sup>1</sup> This is the stroke up to the mechanical stopper.

## Motor Attachment Details

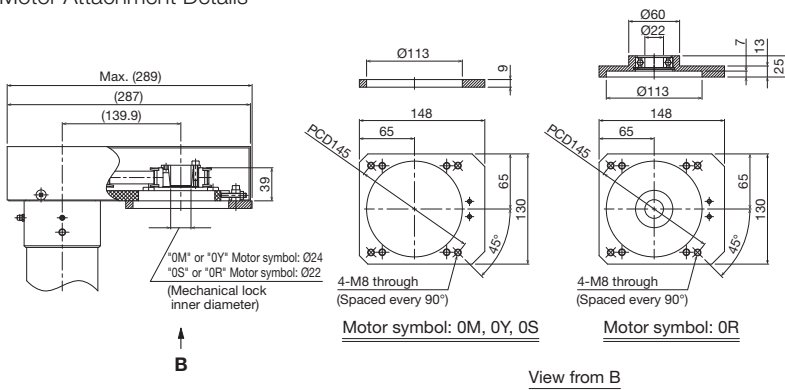

Stroke (mm) (Stroke between mechanical stoppers)	50 (60)	100 (110)	150 (160)	200 (210)	250 (260)
Dimensions (mm)					
A	271	321	371	421	471
B	83	93	113	163	213
Mass <sup>2</sup> (kg)					
0M, 0Y, 0S	17.1	18.7	20.3	21.9	23.5
0R	18	19.6	21.2	22.8	24.4

<sup>2</sup> The final character of the symbol indicates the manufacturer. Respectively, M: Mitsubishi Electric Corporation; Y: YASKAWA Electric Corporation; S: SANYO DENKI CO., LTD.; and R: OMRON Corporation.

# PC50-06D

Rod diameter  
**50 mm**

Motor  
**wrap**

Max. stroke  
**250 mm**

## Model Number Coding

Model ①	Lead, reduction ratio ②	Stroke ③	Design symbol ④	Option (lubrication site) ⑤	Compatible motor bracket ⑥
PC50 <b>PC50</b>	06D <b>06D</b>	0200 <b>0050: 50 mm</b> to <b>0250: 250 mm</b>	B <b>B</b>	R <b>D: Bottom</b> <b>L: Left</b> <b>R: Right</b>	0M <b>0M: Without motor</b> <b>0Y: Without motor</b> <b>0S: Without motor</b> <b>0R: Without motor</b>

### Compatible Motor Bracket Symbol Coding

0	Y
Without motor	M: Mitsubishi Electric Corporation Y: YASKAWA Electric Corporation S: SANYO DENKI CO., LTD. R: OMRON Corporation

### ⑤ Option (lubrication site)

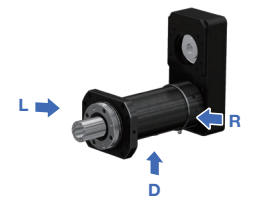
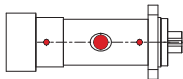
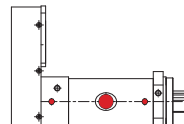
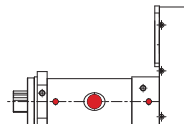
Lubrication site Symbol	Bottom D	Left L	Right R
Rough drawing of lubrication site 			

## Selection Information

### Basic Specifications<sup>1</sup>

Ball screw lead (mm)	6	
Reduction ratio	30/40	
Permissible axial load <sup>2</sup> (kN)	Pressing direction	22.4
	Pulling direction	8.4
Positioning repeatability (mm)	±0.005	
Backlash (mm)	0.02	
Permissible input torque <sup>3</sup> (N·m)	18.9	

- <sup>1</sup> The guideline value for the maximum acceleration/deceleration is 0.1 G.  
<sup>2</sup> The permissible axial load value shows the load that the product can bear while the actuator is stationary.  
<sup>3</sup> There is a risk of damage to the mechanical parts. Only use the motor within the permissible input torque range.  
 Note 1: Prepare a separate guide mechanism if a load will be applied to the rod in a non-axial direction.

### Theoretical Press Service Life (Press Cycles)

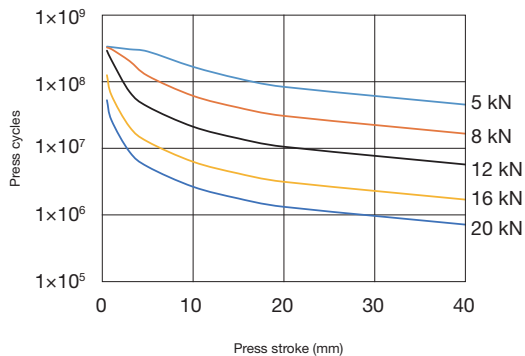

Service life will vary depending on press load and press stroke. Operating life values are theoretical based on the below conditions.  
 Mounting orientation: Vertical (rod facing down)  
 Pressing direction: Compression direction  
 Load mass: 75kg

Note 2: This graph is not a guarantee of press stroke operations under a press load.

### Maintenance

For greasing of the ball screw, remove the plug and apply grease directly to the ball screw shaft.  
 Lubricate the product with the rod extended to the lubrication site.

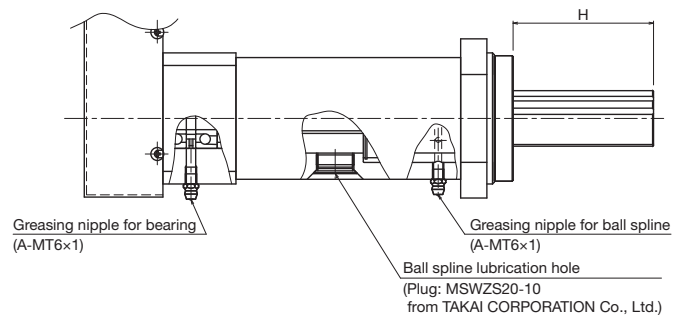

Stroke	50	100	150	200	250
Lubrication site: H	83	133	173	173	173

Unit: mm

# Dimensions

This figure shows lubrication site D (bottom).

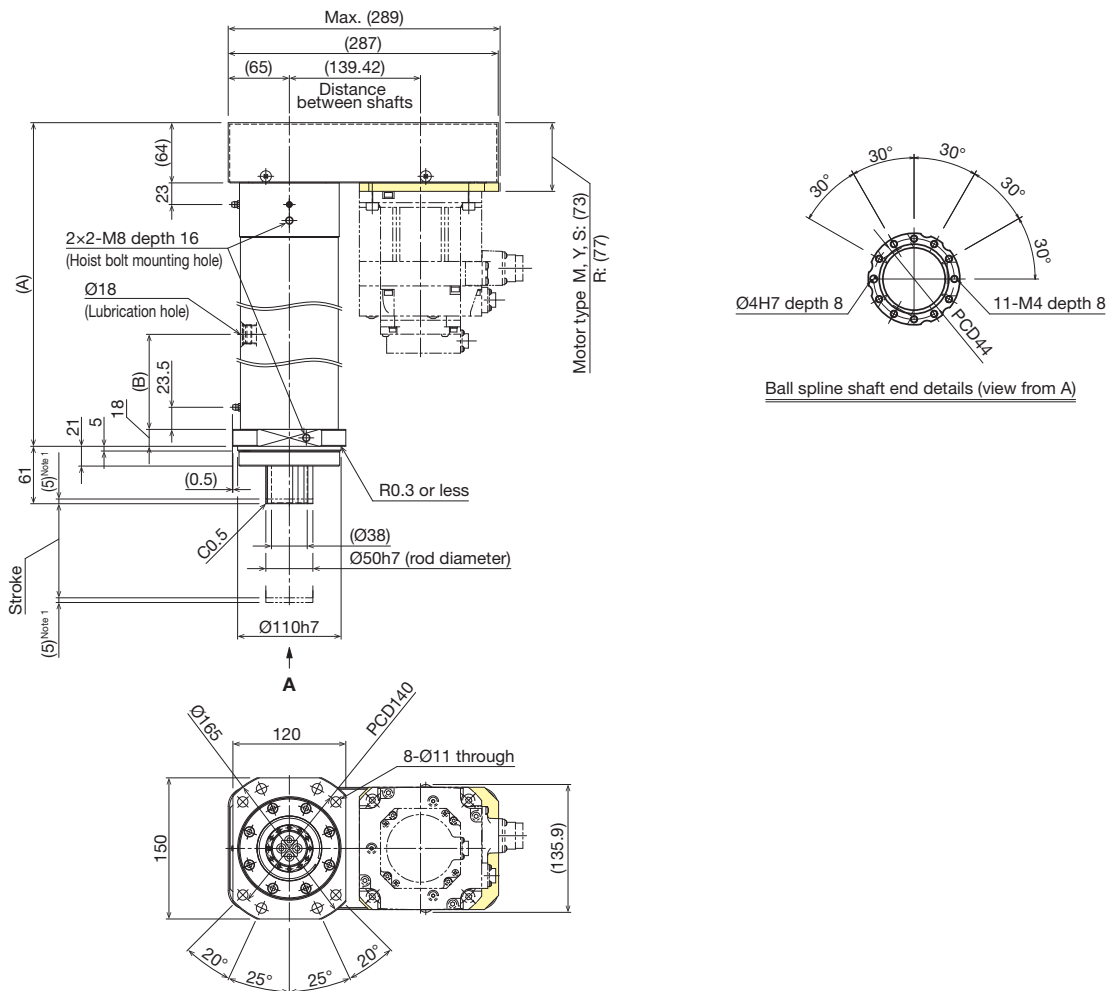

<sup>1</sup> This is the stroke up to the mechanical stopper.

## Motor Attachment Details

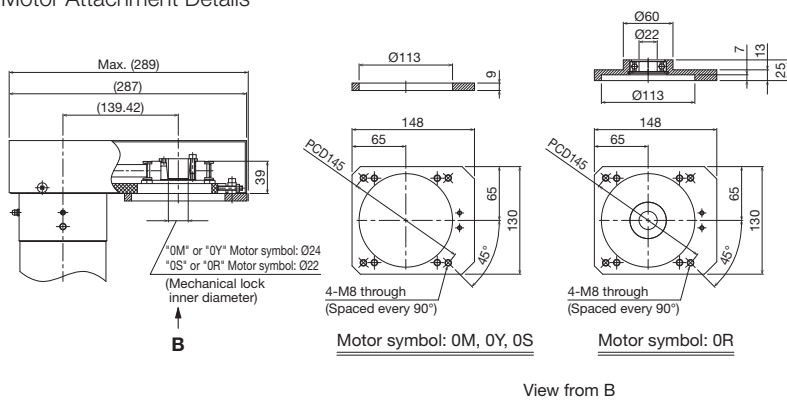

Stroke (mm) (Stroke between mechanical stoppers)	50 (60)	100 (110)	150 (160)	200 (210)	250 (260)	
Dimensions (mm)						
A	294	344	394	444	494	
B	101		111	161	211	
Mass <sup>2</sup> (kg)	0M, 0Y, 0S	24.5	27.1	29.7	32.2	34.8
	0R	25.4	28	30.6	33.1	35.7

<sup>2</sup> The final character of the symbol indicates the manufacturer. Respectively, M: Mitsubishi Electric Corporation; Y: YASKAWA Electric Corporation; S: SANYO DENKI CO., LTD.; and R: OMRON Corporation.

# PC60-10E

Rod diameter  
**60 mm**

Motor  
**wrap**

Max. stroke  
**250 mm**

## Model Number Coding

Model ①	Lead, reduction ratio ②	Stroke ③	Design symbol ④	Option (lubrication site) ⑤	Compatible motor bracket ⑥
PC60 <b>PC60</b>	10E <b>10E</b>	0200 <b>0050: 50 mm</b> to <b>0250: 250 mm</b>	B <b>B</b>	R <b>D: Bottom</b> <b>L: Left</b> <b>R: Right</b>	OM <b>OM: Without motor</b> <b>OY: Without motor</b> <b>OS: Without motor</b> <b>OR: Without motor</b>

### Compatible Motor Bracket Symbol Coding

0	Y
Without motor	M: Mitsubishi Electric Corporation Y: YASKAWA Electric Corporation S: SANYO DENKI CO., LTD. R: OMRON Corporation

### ⑤ Option (lubrication site)

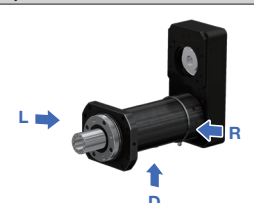
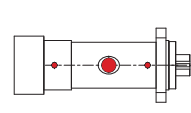
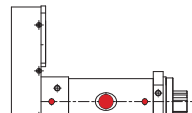
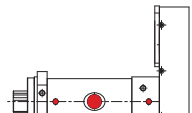
Lubrication site Symbol	Bottom D	Left L	Right R
Rough drawing of lubrication site 			

## Selection Information

### Basic Specifications<sup>1</sup>

Ball screw lead (mm)	10	
Reduction ratio	28/60	
Permissible axial load <sup>2</sup> (kN)	Pressing direction	31.1
	Pulling direction	10.9
Positioning repeatability (mm)	±0.005	
Backlash (mm)	0.02	
Permissible input torque <sup>3</sup> (N·m)	27.2	

<sup>1</sup> The guideline value for the maximum acceleration/deceleration is 0.1 G.

<sup>2</sup> The permissible axial load value shows the load that the product can bear while the actuator is stationary.

<sup>3</sup> There is a risk of damage to the mechanical parts. Only use the motor within the permissible input torque range.

Note 1: Prepare a separate guide mechanism if a load will be applied to the rod in a non-axial direction.

### Theoretical Press Service Life (Press Cycles)

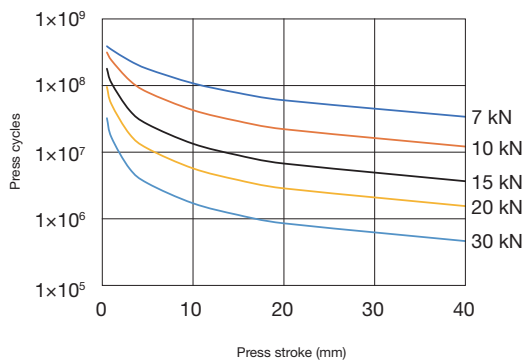

Service life will vary depending on press load and press stroke. Operating life values are theoretical based on the below conditions.

Mounting orientation: Vertical (rod facing down)  
Pressing direction: Compression direction  
Load mass: 100kg

Note 2: This graph is not a guarantee of press stroke operations under a press load.

### Maintenance

For greasing of the ball screw, remove the plug and apply grease directly to the ball screw shaft.

Lubricate the product with the rod extended to the lubrication site.

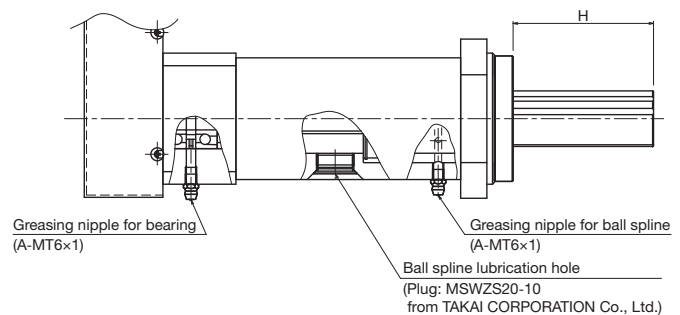

Stroke	50	100	150	200	250
Lubrication site: H	91	141	191	191	191

Unit: mm

# Dimensions

This figure shows lubrication site D (bottom).

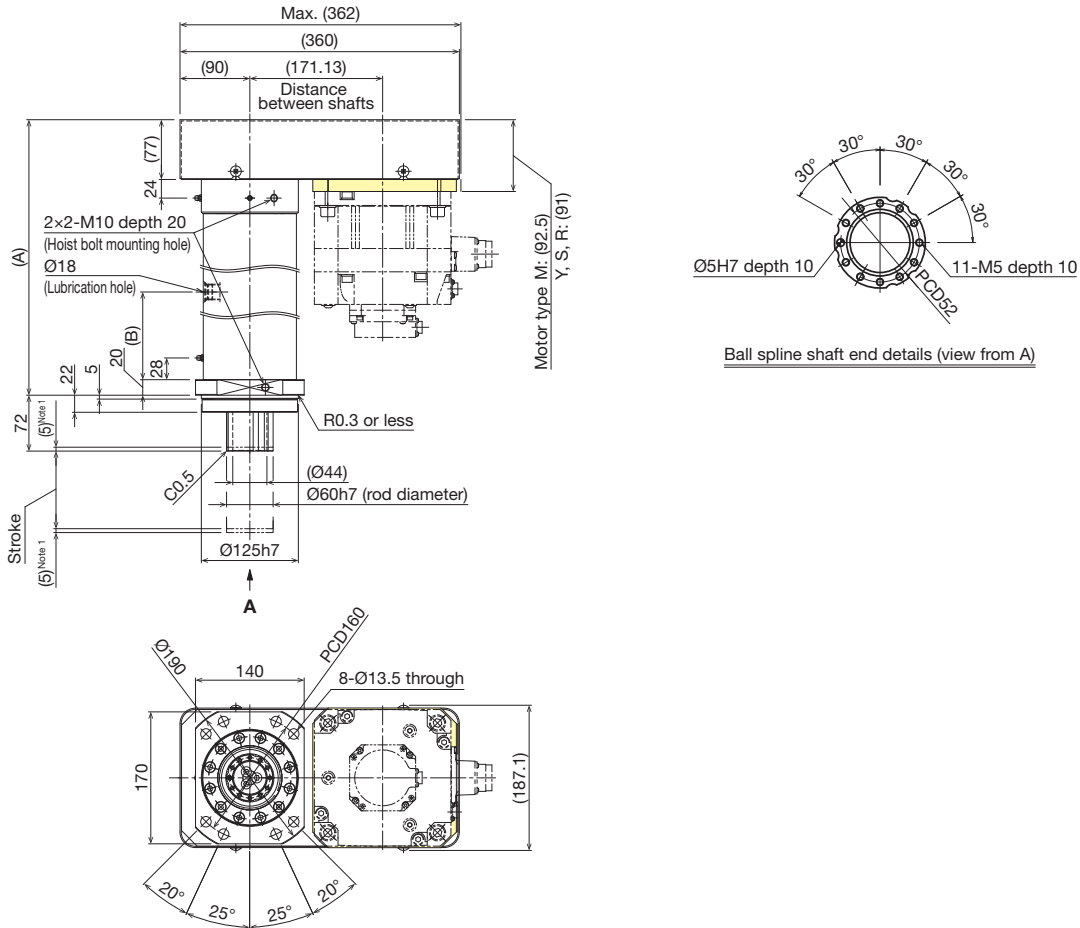

<sup>1</sup> This is the stroke up to the mechanical stopper.

## Motor Attachment Details

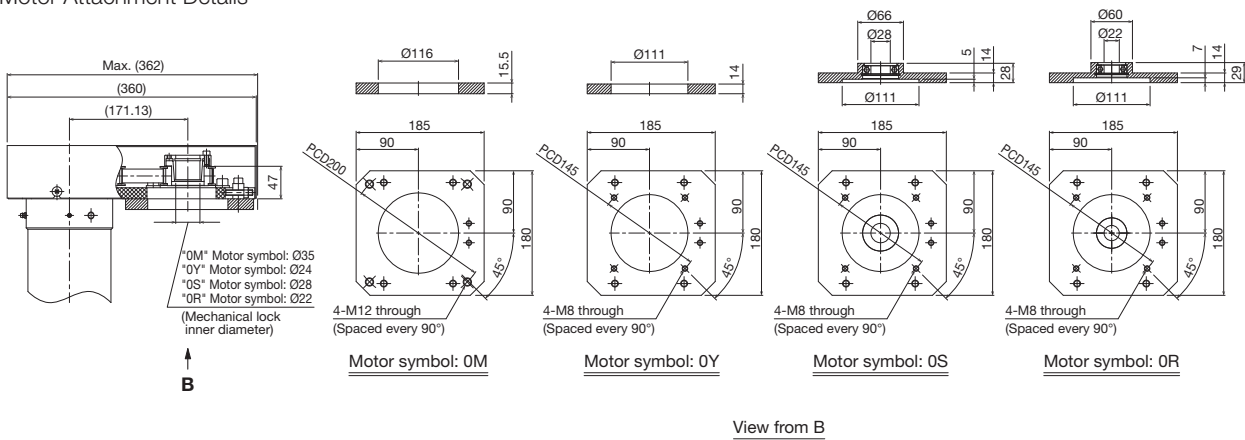

Stroke (mm) (Stroke between mechanical stoppers)	50 (60)	100 (110)	150 (160)	200 (210)	250 (260)	
Dimensions (mm)						
A	305	355	405	455	505	
B		113		163	213	
Mass <sup>2</sup> (kg)	OM, OS, OR	40.4	44	47.6	51.2	54.7
	OY	39.6	43.2	46.8	50.4	53.9

<sup>2</sup> The final character of the symbol indicates the manufacturer. Respectively, M: Mitsubishi Electric Corporation; Y: YASKAWA Electric Corporation; S: SANYO DENKI CO., LTD.; and R: OMRON Corporation.

# PC60H-10F

Rod diameter  
**60 mm**

Motor  
**wrap**

Max. stroke  
**250 mm**

## Model Number Coding

Model ①	Lead, reduction ratio ②	Stroke ③	Design symbol ④	Option (lubrication site) ⑤	Compatible motor bracket ⑥
PC60H <b>PC60H</b>	10F <b>10F</b>	0200 <b>0050: 50 mm</b> to <b>0250: 250 mm</b>	B <b>B</b>	R <b>D: Bottom</b> <b>L: Left</b> <b>R: Right</b>	OM <b>OM: Without motor</b> <b>OY: Without motor</b> <b>OS: Without motor</b> <b>OR: Without motor</b>

### Compatible Motor Bracket Symbol Coding

0	Y
Without motor	M: Mitsubishi Electric Corporation Y: YASKAWA Electric Corporation S: SANYO DENKI CO., LTD. R: OMRON Corporation

### ⑤ Option (lubrication site)

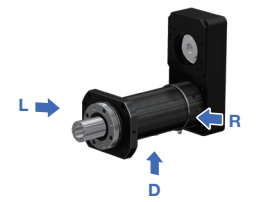
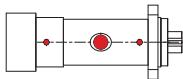
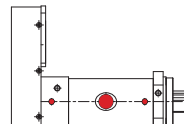
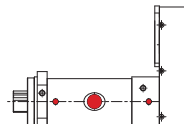
Lubrication site Symbol	Bottom D	Left L	Right R
Rough drawing of lubrication site 			

## Selection Information

### Basic Specifications<sup>1</sup>

Ball screw lead (mm)	10	
Reduction ratio	30/60	
Permissible axial load <sup>2</sup> (kN)	Pressing direction	35.6
	Pulling direction	17.8
Positioning repeatability (mm)	±0.005	
Backlash (mm)	0.02	
Permissible input torque <sup>3</sup> (N·m)	33.4	

<sup>1</sup> The guideline value for the maximum acceleration/deceleration is 0.1 G.

<sup>2</sup> The permissible axial load value shows the load that the product can bear while the actuator is stationary.

<sup>3</sup> There is a risk of damage to the mechanical parts. Only use the motor within the permissible input torque range.

Note 1: Prepare a separate guide mechanism if a load will be applied to the rod in a non-axial direction.

### Theoretical Press Service Life (Press Cycles)

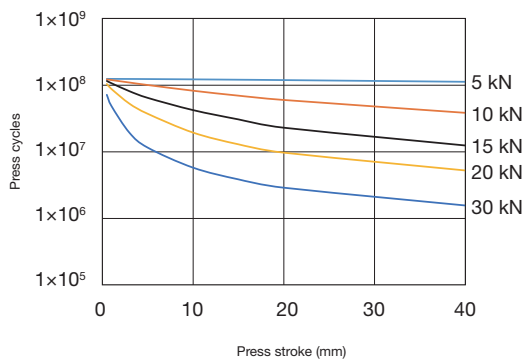

Service life will vary depending on press load and press stroke. Operating life values are theoretical based on the below conditions.

Mounting orientation: Vertical (rod facing down)  
Pressing direction: Compression direction  
Load mass: 150kg

Note 2: This graph is not a guarantee of press stroke operations under a press load.

### Maintenance

For greasing of the ball screw, remove the plug and apply grease directly to the ball screw shaft.

Lubricate the product with the rod extended to the lubrication site.

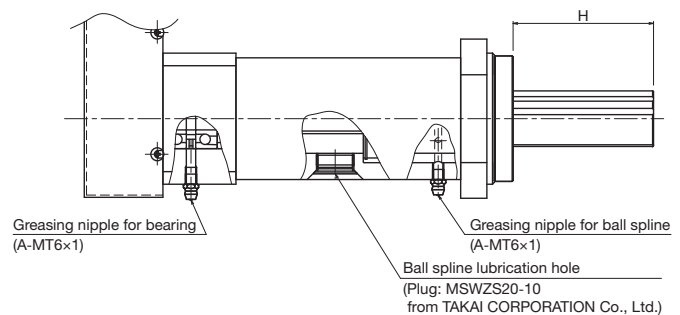

Stroke	50	100	150	200	250
Lubrication site: H	100	150	200	230	230

Unit: mm

# Dimensions

This figure shows lubrication site D (bottom).

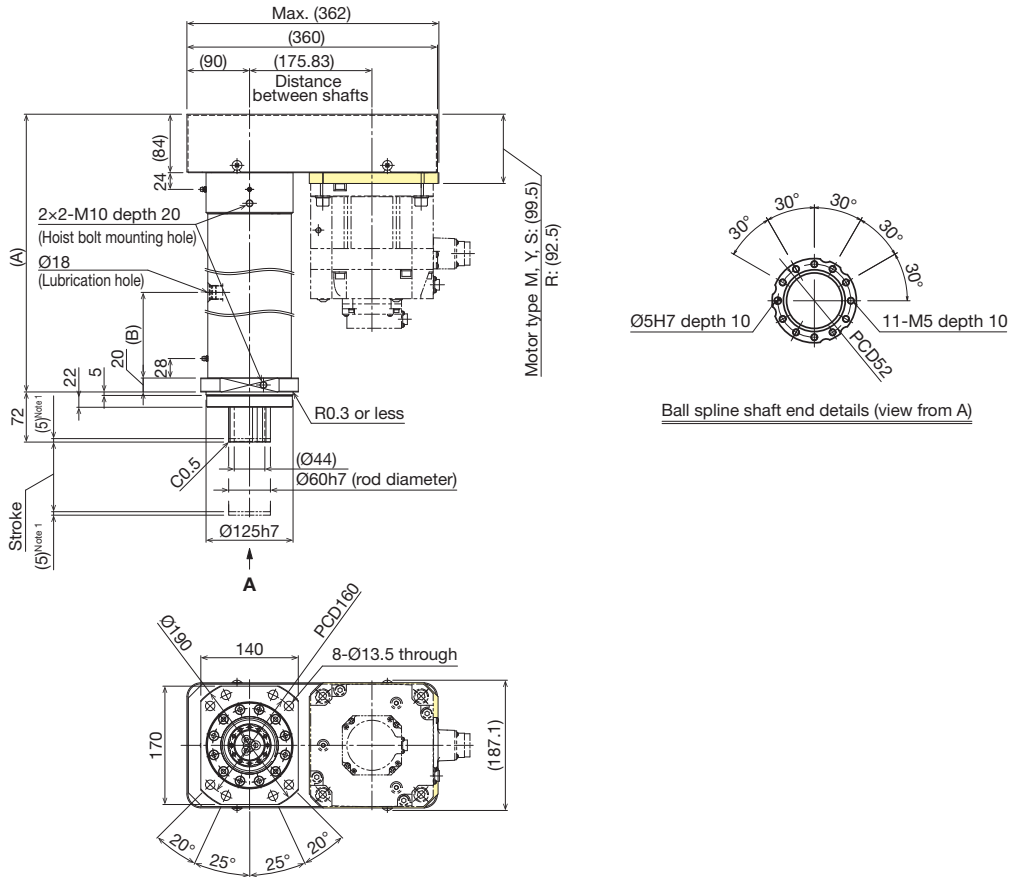

<sup>1</sup> This is the stroke up to the mechanical stopper.

## Motor Attachment Details

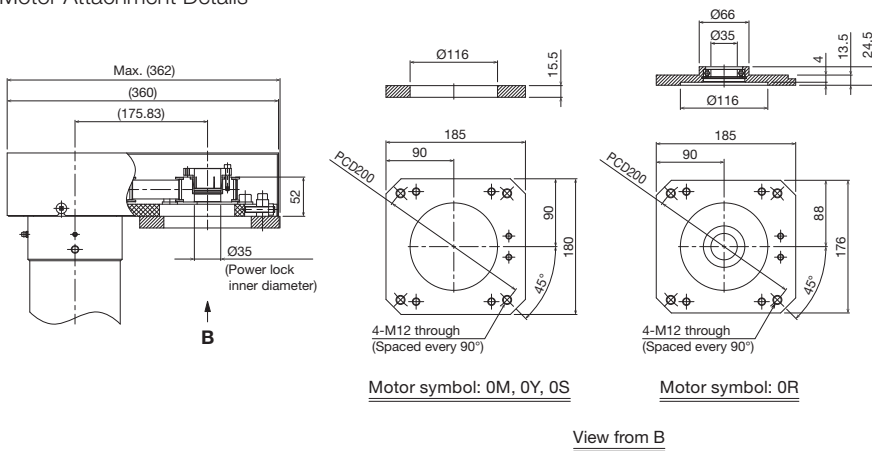

Stroke (mm) (Stroke between mechanical stoppers)	50 (60)	100 (110)	150 (160)	200 (210)	250 (260)
Dimensions (mm)					
A	349	399	449	499	549
B		123		145	195
Mass <sup>2</sup> (kg)					
0M, 0Y, 0S	44.3	47.9	51.5	55.1	58.6
0R	43.7	47.3	50.9	54.5	58.1

<sup>2</sup> The final character of the symbol indicates the manufacturer. Respectively, M: Mitsubishi Electric Corporation; Y: YASKAWA Electric Corporation; S: SANYO DENKI CO., LTD.; and R: OMRON Corporation.

# PC80L-12G

Rod diameter  
**80 mm**

Motor  
**wrap**

Max. stroke  
**250 mm**

## Model Number Coding

Model ①	Lead, reduction ratio ②	Stroke ③	Design symbol ④	Option (lubrication site) ⑤	Compatible motor bracket ⑥
PC80L	12G	0200	B	R	0M
<b>PC80L</b>	<b>12G</b>	<b>0050: 50 mm</b> to <b>0250: 250 mm</b>	<b>B</b>	<b>D: Bottom</b> <b>L: Left</b> <b>R: Right</b>	<b>0M: Without motor</b> <b>0Y: Without motor</b> <b>0S: Without motor</b> <b>0R: Without motor</b>

### Compatible Motor Bracket Symbol Coding

0	Y
Without motor	M: Mitsubishi Electric Corporation Y: YASKAWA Electric Corporation S: SANYO DENKI CO., LTD. R: OMRON Corporation

### ⑤ Option (lubrication site)

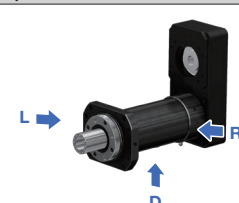
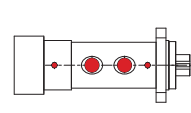
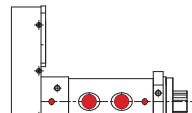
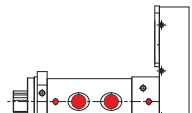
Lubrication site Symbol	Bottom D	Left L	Right R
Rough drawing of lubrication site 			

## Selection Information

### Basic Specifications<sup>1</sup>

Ball screw lead (mm)	12	
Reduction ratio	40/90	
Permissible axial load <sup>2</sup> (kN)	Pressing direction	120
	Pulling direction	48
Positioning repeatability (mm)	±0.005	
Backlash (mm)	0.02	
Permissible input torque <sup>3</sup> (N·m)	75	

<sup>1</sup> The guideline value for the maximum acceleration/deceleration is 0.1 G.

<sup>2</sup> The permissible axial load value shows the load that the product can bear while the actuator is stationary.

<sup>3</sup> There is a risk of damage to the mechanical parts. Only use the motor within the permissible input torque range.

Note 1: Prepare a separate guide mechanism if a load will be applied to the rod in a non-axial direction.

### Theoretical Press Service Life (Press Cycles)

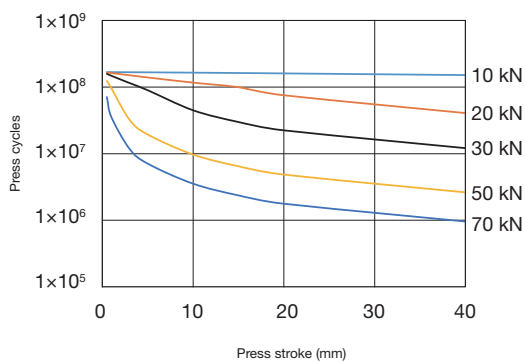

Service life will vary depending on press load and press stroke. Operating life values are theoretical based on the below conditions.

- Mounting orientation: Vertical (rod facing down)
- Pressing direction: Compression direction
- Load mass: 200kg

Note 2: This graph is not a guarantee of press stroke operations under a press load.

### Maintenance

For greasing of the ball screw, remove the plug and supply grease through the ball screw lubrication hole.

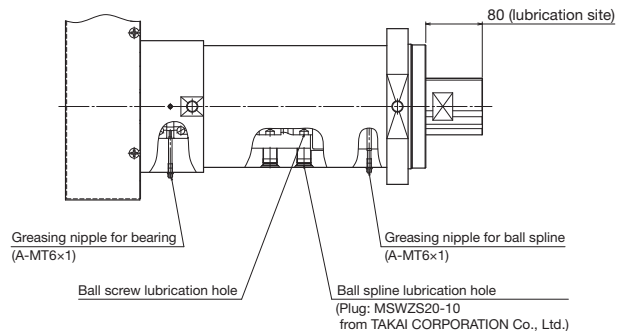

# Dimensions

This figure shows lubrication site D (bottom).

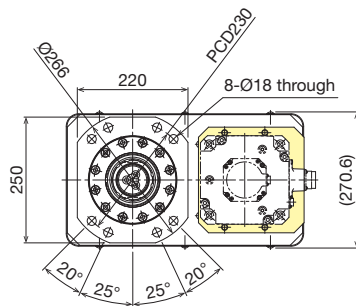
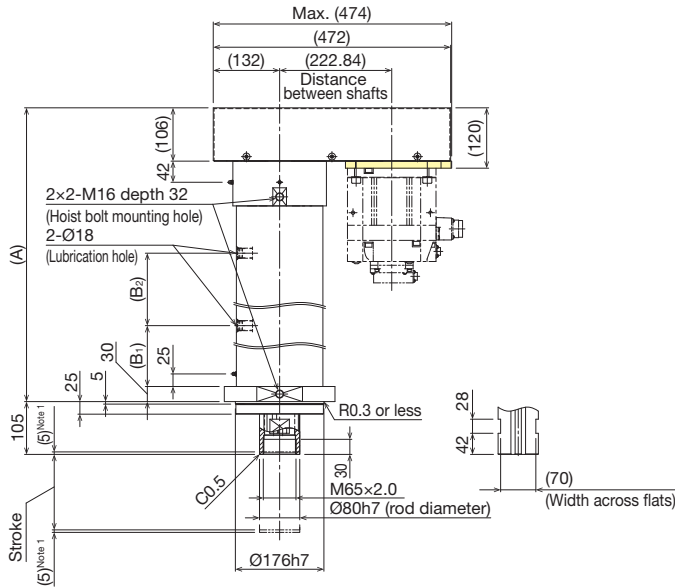

<sup>1</sup> This is the stroke up to the mechanical stopper.

## Motor Attachment Details

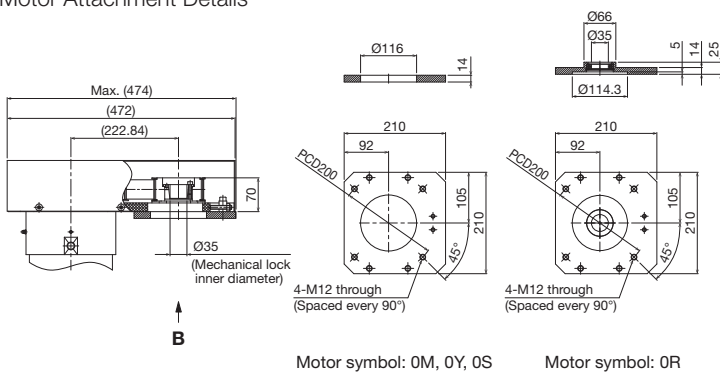

View from B

Stroke (mm) (Stroke between mechanical stoppers)	50 (60)	100 (110)	150 (160)	200 (210)	250 (260)
Dimensions (mm)					
A	484	534	584	634	684
B <sub>1</sub>	117	119	121	171	221
B <sub>2</sub>	48	96		144	
Mass <sup>2</sup> (kg)					
0M, 0Y, 0S	117.4	124.6	131.9	139.2	146.4
0R	118.1	125.4	132.7	139.9	147.2

<sup>2</sup> The final character of the symbol indicates the manufacturer. Respectively, M: Mitsubishi Electric Corporation; Y: YASKAWA Electric Corporation; S: SANYO DENKI CO., LTD.; and R: OMRON Corporation.

# PC80-12G

Rod diameter <b>80 mm</b>	Motor <b>wrap</b>	Max. stroke <b>250 mm</b>
------------------------------	----------------------	------------------------------

## Model Number Coding

Model ①	Lead, reduction ratio ②	Stroke ③	Design symbol ④	Option (lubrication site) ⑤	Compatible motor bracket ⑥
PC80	12G	0200	B	R	0M
<b>PC80</b>	<b>12G</b>	<b>0050: 50 mm</b> to <b>0250: 250 mm</b>	<b>B</b>	<b>D: Bottom</b> <b>L: Left</b> <b>R: Right</b>	<b>0M: Without motor</b> <b>0Y: Without motor</b> <b>0S: Without motor</b> <b>0R: Without motor</b>

Compatible Motor Bracket Symbol Coding

0	Y
Without motor	M: Mitsubishi Electric Corporation Y: YASKAWA Electric Corporation S: SANYO DENKI CO., LTD. R: OMRON Corporation

### ⑤ Option (lubrication site)

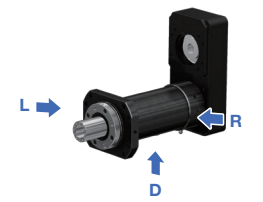
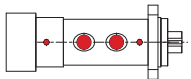
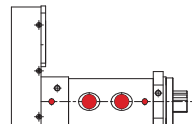
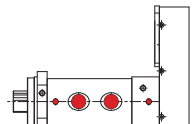
Lubrication site Symbol	Bottom D	Left L	Right R
Rough drawing of lubrication site 			

## Selection Information

### Basic Specifications<sup>1</sup>

Ball screw lead (mm)	12	
Reduction ratio	40/90	
Permissible axial load <sup>2</sup> (kN)	Pressing direction	120
	Pulling direction	48
Positioning repeatability (mm)	±0.005	
Backlash (mm)	0.02	
Permissible input torque <sup>3</sup> (N·m)	107	

<sup>1</sup> The guideline value for the maximum acceleration/deceleration is 0.1 G.  
<sup>2</sup> The permissible axial load value shows the load that the product can bear while the actuator is stationary.  
<sup>3</sup> There is a risk of damage to the mechanical parts. Only use the motor within the permissible input torque range.  
 Note 1: Prepare a separate guide mechanism if a load will be applied to the rod in a non-axial direction.

### Theoretical Press Service Life (Press Cycles)

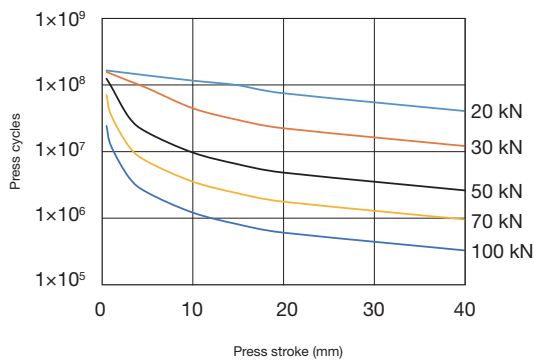

Service life will vary depending on press load and press stroke. Operating life values are theoretical based on the below conditions.  
 Mounting orientation: Vertical (rod facing down)  
 Pressing direction: Compression direction  
 Load mass: 200kg

Note 2: This graph is not a guarantee of press stroke operations under a press load.

### Maintenance

For greasing of the ball screw, remove the plug and supply grease through the ball screw lubrication hole.

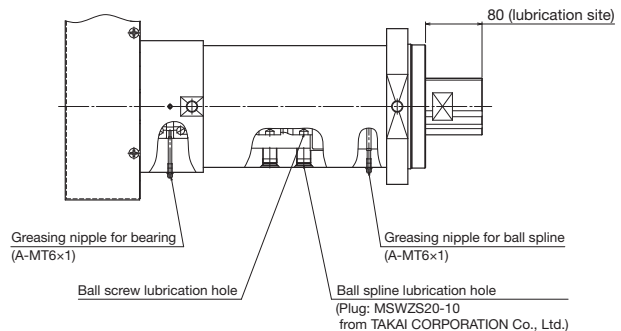

# Dimensions

This figure shows lubrication site D (bottom).

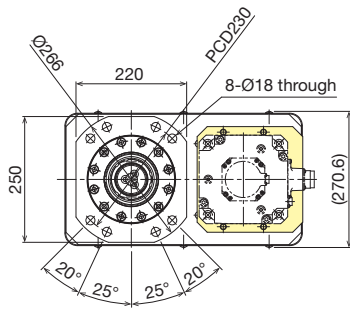
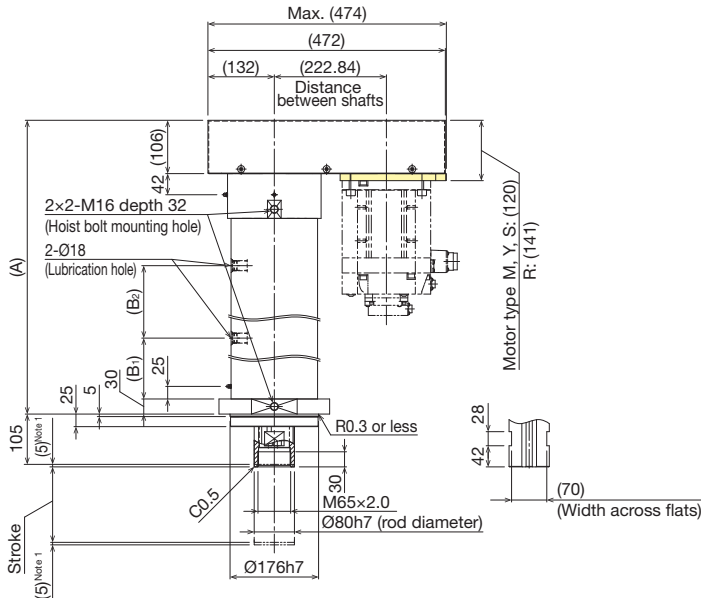

<sup>1</sup> This is the stroke up to the mechanical stopper.

## Motor Attachment Details

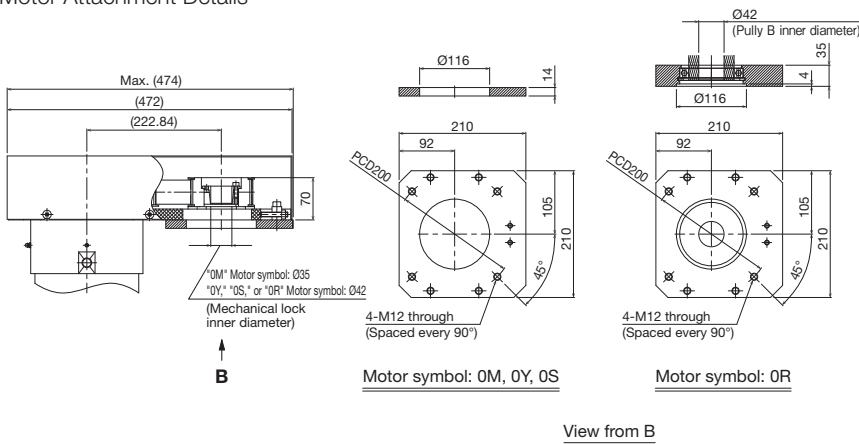

Stroke (mm) (Stroke between mechanical stoppers)	50 (60)	100 (110)	150 (160)	200 (210)	250 (260)
Dimensions (mm)					
A	484	534	584	634	684
B <sub>1</sub>	117	119	121	171	221
B <sub>2</sub>	48	96		144	
Mass <sup>2</sup> (kg)					
OM, OY, OS	117.4	124.6	131.9	139.2	146.4
OR	125	132.3	139.6	146.8	154.1

<sup>2</sup> The final character of the symbol indicates the manufacturer. Respectively, M: Mitsubishi Electric Corporation; Y: YASKAWA Electric Corporation; S: SANYO DENKI CO., LTD.; and R: OMRON Corporation.

# PC80H-12G

Rod diameter <b>80 mm</b>	Motor <b>wrap</b>	Max. stroke <b>250 mm</b>
------------------------------	----------------------	------------------------------

## Model Number Coding

Model ①	Lead, reduction ratio ②	Stroke ③	Design symbol ④	Option (lubrication site) ⑤	Compatible motor bracket ⑥
PC80H <b>PC80H</b>	12G <b>12G</b>	0200 <b>0050: 50 mm</b> to <b>0250: 250 mm</b>	B <b>B</b>	R <b>D: Bottom</b> <b>L: Left</b> <b>R: Right</b>	OM <b>OM: Without motor</b> <b>OY: Without motor</b> <b>OS: Without motor</b> <b>OR: Without motor</b>

Compatible Motor Bracket Symbol Coding

0	Y
Without motor	M: Mitsubishi Electric Corporation Y: YASKAWA Electric Corporation S: SANYO DENKI CO., LTD. R: OMRON Corporation

### ⑤ Option (lubrication site)

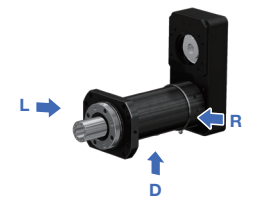
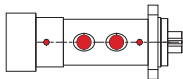
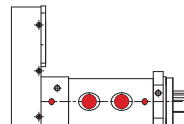
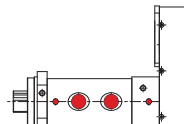
Lubrication site Symbol	Bottom D	Left L	Right R
Rough drawing of lubrication site 			

## Selection Information

### Basic Specifications<sup>1</sup>

Ball screw lead (mm)	12	
Reduction ratio	40/90	
Permissible axial load <sup>2</sup> (kN)	Pressing direction	120
	Pulling direction	48
Positioning repeatability (mm)	±0.005	
Backlash (mm)	0.02	
Permissible input torque <sup>3</sup> (N·m)	120	

<sup>1</sup> The guideline value for the maximum acceleration/deceleration is 0.1 G.  
<sup>2</sup> The permissible axial load value shows the load that the product can bear while the actuator is stationary.  
<sup>3</sup> There is a risk of damage to the mechanical parts. Only use the motor within the permissible input torque range.  
 Note 1: Prepare a separate guide mechanism if a load will be applied to the rod in a non-axial direction.

### Theoretical Press Service Life (Press Cycles)

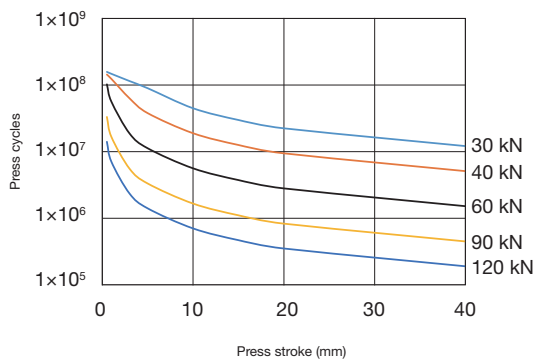

Service life will vary depending on press load and press stroke. Operating life values are theoretical based on the below conditions.  
 Mounting orientation: Vertical (rod facing down)  
 Pressing direction: Compression direction  
 Load mass: 200kg

Note 2: This graph is not a guarantee of press stroke operations under a press load.

### Maintenance

For greasing of the ball screw, remove the plug and supply grease through the ball screw lubrication hole.

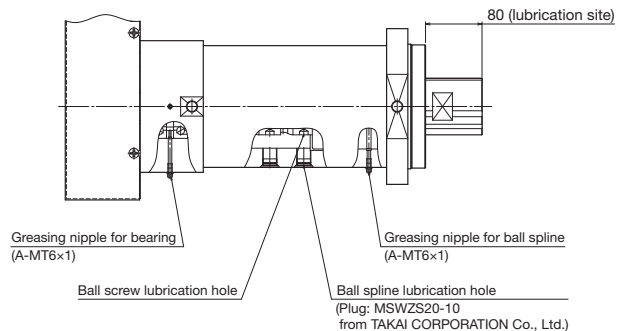

# Dimensions

This figure shows lubrication site D (bottom).

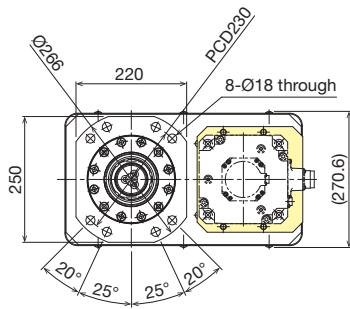
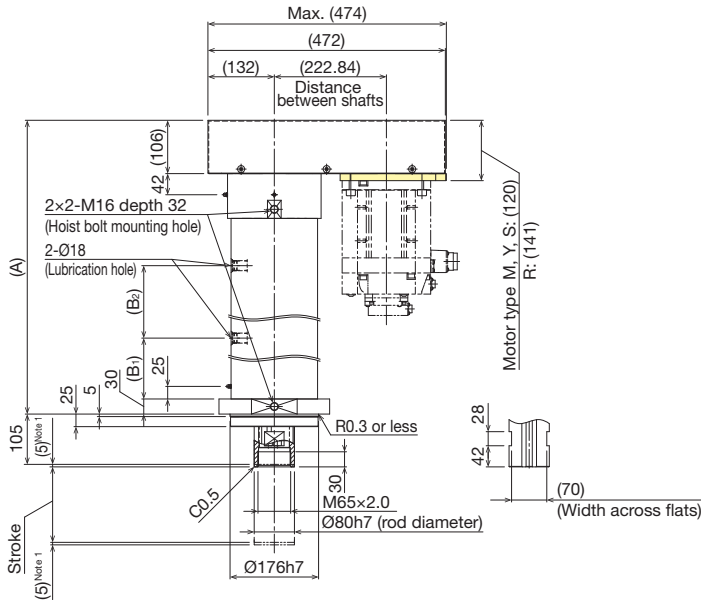

<sup>1</sup> This is the stroke up to the mechanical stopper.

## Motor Attachment Details

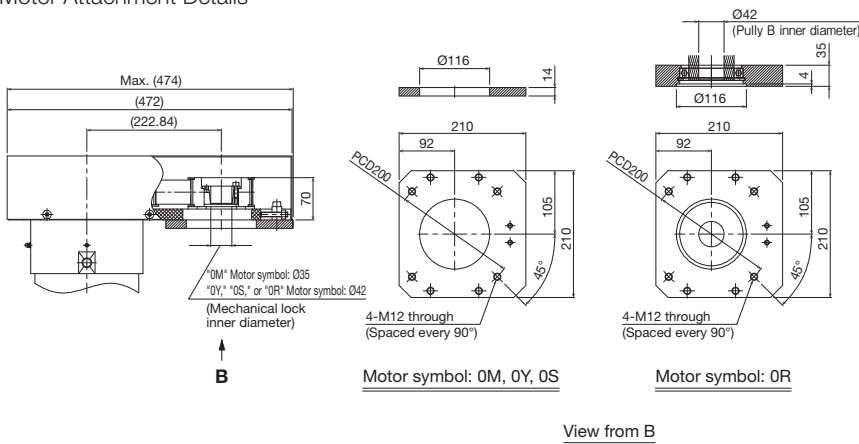

Stroke (mm) (Stroke between mechanical stoppers)	50 (60)	100 (110)	150 (160)	200 (210)	250 (260)
Dimensions (mm)					
A	484	534	584	634	684
B <sub>1</sub>	125	132.3	139.6	146.8	154.1
B <sub>2</sub>	48	96		144	
Mass <sup>2</sup> (kg)					
OM, OY, OS	117.4	124.6	131.9	139.2	146.4
OR	125	132.3	139.6	146.8	154.1

<sup>2</sup> The final character of the symbol indicates the manufacturer. Respectively, M: Mitsubishi Electric Corporation; Y: YASKAWA Electric Corporation; S: SANYO DENKI CO., LTD.; and R: OMRON Corporation.

# PC100-20H

Rod diameter <b>100 mm</b>	Motor <b>wrap</b>	Max. stroke <b>400 mm</b>
-------------------------------	----------------------	------------------------------

## Model Number Coding

Model ①	Lead, reduction ratio ②	Stroke ③	Design symbol ④	Option (lubrication site) ⑤	Compatible motor bracket ⑥
PC100 <b>PC100</b>	20H <b>20H</b>	0400 <b>0200: 200 mm</b> <b>0400: 400 mm</b>	A <b>A</b>	D <b>D: Bottom</b> <b>L: Left</b> <b>R: Right</b>	0M <b>0M: Without motor</b> <b>0Y: Without motor</b> <b>0S: Without motor</b> <b>0R: Without motor</b>

Note 1: This product will be shipped with a reduction gear installed.

### Compatible Motor Bracket Symbol Coding

0	Y
Without motor	M: Mitsubishi Electric Corporation Y: YASKAWA Electric Corporation S: SANYO DENKI CO., LTD. R: OMRON Corporation

### ⑤ Option (lubrication site)

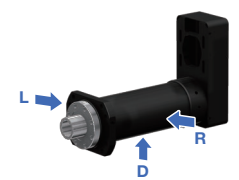
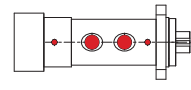
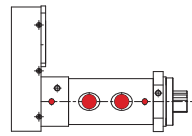
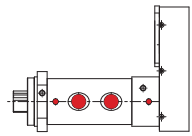
Lubrication site Symbol	Bottom D	Left L	Right R
Rough drawing of lubrication site 			

## Selection Information

### Basic Specifications<sup>1</sup>

Ball screw lead (mm)	20	
Reduction ratio (pulley ratio)	38/38	
Reduction ratio (reduction gear)	1/4	
Permissible axial load <sup>2</sup> (kN)	Pressing direction	175
	Pulling direction	70
Positioning repeatability (mm)	±0.01	
Backlash (mm)	0.02	
Permissible input torque <sup>3</sup> (N·m)	175	

<sup>1</sup> The guideline value for the maximum acceleration/deceleration is 0.1 G.

<sup>2</sup> The permissible axial load value shows the load that the product can bear while the actuator is stationary.

<sup>3</sup> There is a risk of damage to the mechanical parts. Only use the motor within the permissible input torque range.

Note 2: Prepare a separate guide mechanism if a load will be applied to the rod in a non-axial direction.

### Theoretical Press Service Life (Press Cycles)

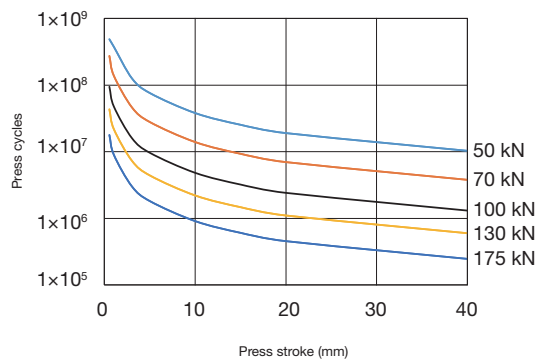

Service life will vary depending on press load and press stroke. Operating life values are theoretical based on the below conditions.

- Mounting orientation: Vertical (rod facing down)
- Pressing direction: Compression direction
- Load mass: 200kg

Note 3: This graph is not a guarantee of press stroke operations under a press load.

### Maintenance

For greasing of the ball screw, remove the plug and supply grease through the ball screw lubrication hole.

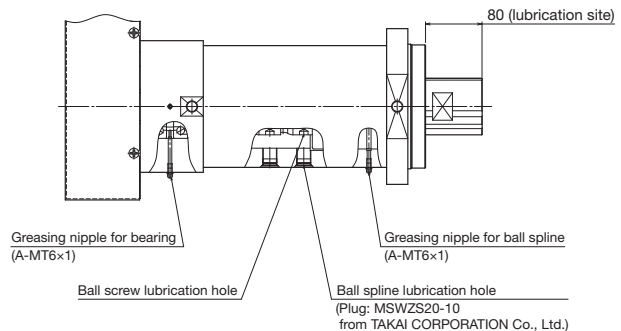

# Dimensions

This figure shows lubrication site D (bottom).

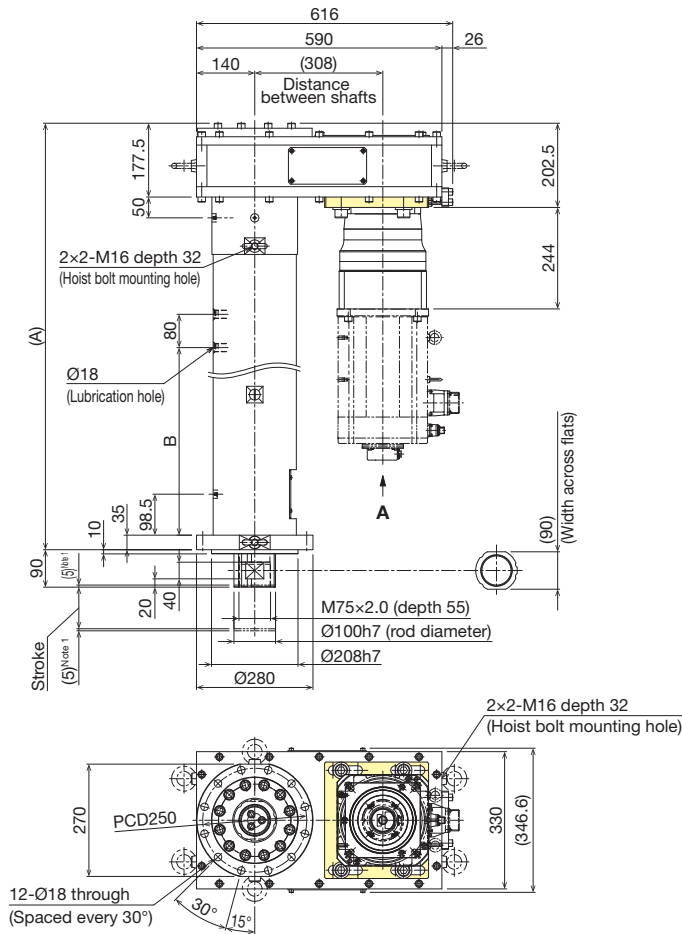

## Motor Attachment Details

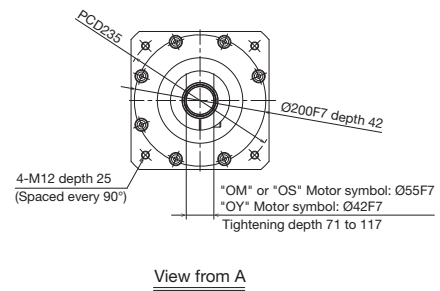

<sup>1</sup> This is the stroke up to the mechanical stopper.

Stroke (mm) (Stroke between mechanical stoppers)	<b>200</b> (210)	<b>400</b> (410)
Dimensions (mm)	A	825.5
	B	251
Mass <sup>2</sup> (kg)	325	363

<sup>2</sup> The mass includes the reduction gear.

# PC120-20J

Rod diameter <b>120 mm</b>	Motor <b>wrap</b>	Max. stroke <b>400 mm</b>
-------------------------------	----------------------	------------------------------

## Model Number Coding

Model ①	Lead, reduction ratio ②	Stroke ③	Design symbol ④	Option (lubrication site) ⑤	Compatible motor bracket ⑥
PC120 <b>PC120</b>	20J <b>20J</b>	0400 <b>0200: 200 mm</b> <b>0400: 400 mm</b>	A <b>A</b>	D <b>D: Bottom</b> <b>L: Left</b> <b>R: Right</b>	0M <b>0M: Without motor</b> <b>0Y: Without motor</b> <b>0S: Without motor</b> <b>0R: Without motor</b>

Note 1: This product will be shipped with a reduction gear installed.

Compatible Motor Bracket Symbol Coding	
0	Y
Without motor	M: Mitsubishi Electric Corporation Y: YASKAWA Electric Corporation S: SANYO DENKI CO., LTD. R: OMRON Corporation

### ⑤ Option (lubrication site)

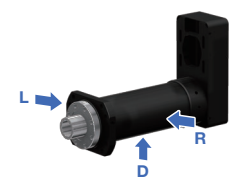
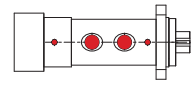
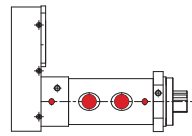
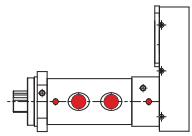
Lubrication site Symbol	Bottom D	Left L	Right R
Rough drawing of lubrication site 			

## Selection Information

### Basic Specifications<sup>1</sup>

Ball screw lead (mm)	20	
Reduction ratio (pulley ratio)	36/40	
Reduction ratio (reduction gear)	1/4	
Permissible axial load <sup>2</sup> (kN)	Pressing direction	250
	Pulling direction	106
Positioning repeatability (mm)	±0.01	
Backlash (mm)	0.02	
Permissible input torque <sup>3</sup> (N·m)	224	

<sup>1</sup> The guideline value for the maximum acceleration/deceleration is 0.1 G.  
<sup>2</sup> The permissible axial load value shows the load that the product can bear while the actuator is stationary.  
<sup>3</sup> There is a risk of damage to the mechanical parts. Only use the motor within the permissible input torque range.  
 Note 2: Prepare a separate guide mechanism if a load will be applied to the rod in a non-axial direction.

### Theoretical Press Service Life (Press Cycles)

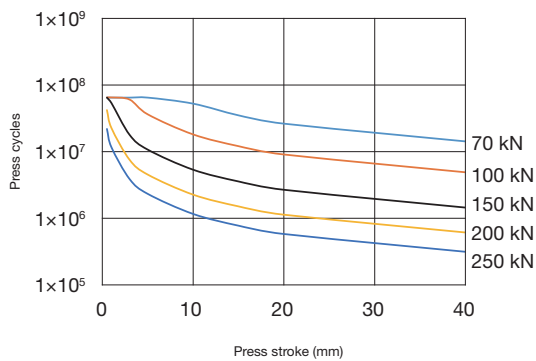

Service life will vary depending on press load and press stroke. Operating life values are theoretical based on the below conditions.  
 Mounting orientation: Vertical (rod facing down)  
 Pressing direction: Compression direction  
 Load mass: 200kg

Note 3: This graph is not a guarantee of press stroke operations under a press load.

### Maintenance

For greasing of the ball screw, remove the plug and supply grease through the ball screw lubrication hole.

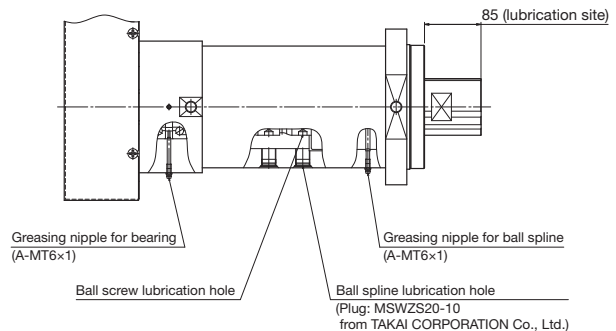

# Dimensions

This figure shows lubrication site D (bottom).

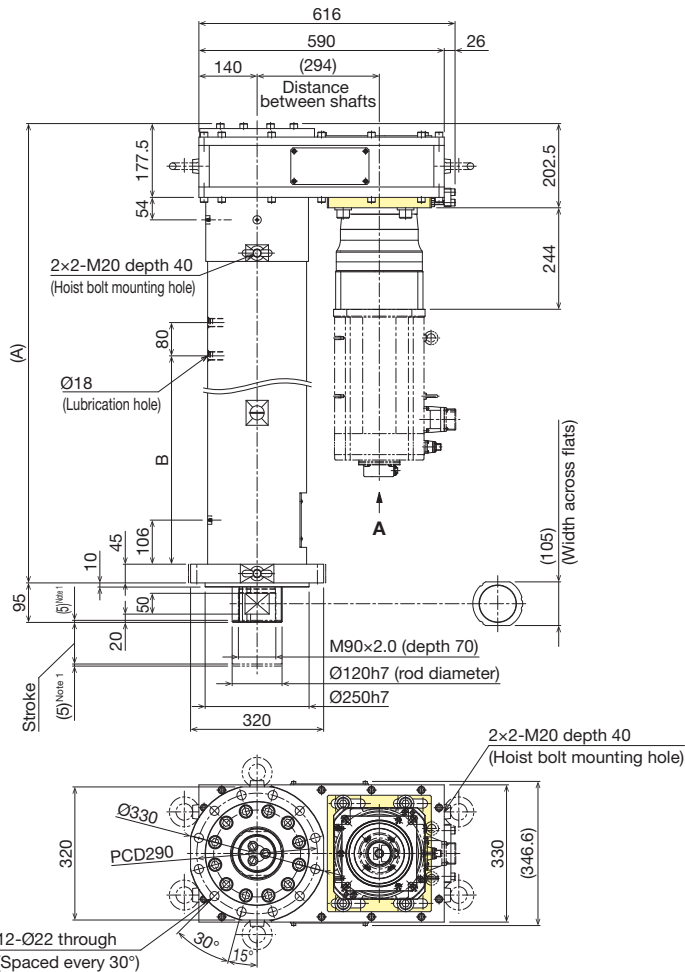

## Motor Attachment Details

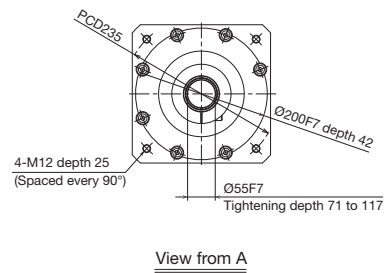

<sup>1</sup> This is the stroke up to the mechanical stopper.

Stroke (mm)		200	400
(Stroke between mechanical stoppers)		(210)	(410)
Dimensions (mm)	A	904.5	1,104.5
	B	301	501
Mass <sup>2</sup> (kg)		426	480

<sup>2</sup> The mass includes the reduction gear.

# PCT20/PCT20R

Rod diameter 20 mm	Direct motor coupling	Motor wrap	Max. stroke 200 mm
-----------------------	--------------------------	---------------	--------------------------

## Model Number Coding

Model ①	Lead, reduction ratio ②	Stroke ③	Options ④	With/without motor ⑤	Motor bracket ⑥	Motor shaft securing method ⑦
PCT20R	06N	0200	R	0	A1	D
PCT20	06N	0050: 50 mm to 0200: 200 mm	With direct coupling N: Direct coupling With motor wrap D: Bottom L: Left R: Right	0: Without motor	A1 K1	With direct coupling No symbol With motor wrap D: Flat K: Key S: Clamp

\*R" indicates motor wrap.

When "PCT20R" is selected for ① Model, "N" cannot be selected.

Direct motor coupling specification: No coupling will be included. Please specify if a coupling is required when ordering.  
Motor wrap specification: Timing pulley and timing belt will be included.

### ④ Option (Motor Wrap)

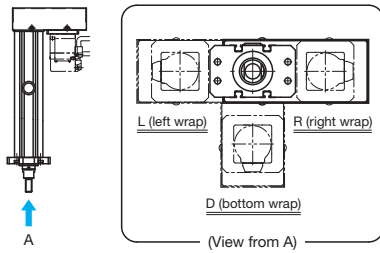

## Motor Bracket and Motor Shaft Securing Method Compatibility

### Direct Coupling

Motor type	Manufacturer	Series	Motor model	Motor rated output (W)	Motor bracket	Compatible coupling
AC servo motor	YASKAWA Electric Corporation	Σ-7	SGM7J-A5	50	A1	SFC-010DA2-6B-8B (MIKI PULLEY CO., LTD.) XGT2-19C-6-8 Nabeya Bi-tech Kaisha (NBK)
			SGM7A-A5			
		Σ-X	SGMJ-A5			
			SGMXA-A5			
	Mitsubishi Electric Corporation	MELSERVO	J4 HG-KR053	50	A1	
			J5 HK-KT053W			
	TAMAGAWA SEIKI CO., LTD.	TBL-III	TS4602	50	A1	
			TBL-IV TSM3102			
	OMRON Corporation	OMNUC	G5 R88M-K05030	50	A1	
			1S R88M-1M05030			
SANYO DENKI CO., LTD.	SANMOTION R	R2□A04005	50	A1		
Panasonic Corporation	MINAS	A6 MSMF5A	50	K1		

### Motor Wrap

Motor type	Manufacturer	Series	Motor model	Motor rated output (W)	Motor bracket	Motor shaft securing method
AC servo motor	YASKAWA Electric Corporation	Σ-7	SGM7J-A5	50	A1	D, K, S
			SGM7A-A5			
		Σ-X	SGMJ-A5			
			SGMXA-A5			
	Mitsubishi Electric Corporation	MELSERVO	J4 HG-KR053	50	A1	D, K, S
			J5 HK-KT053W			
	TAMAGAWA SEIKI CO., LTD.	TBL-III	TS4602	50	A1	D, K, S
			TBL-IV TSM3102			
	OMRON Corporation	OMNUC	G5 R88M-K05030	50	A1	D, K, S
			1S R88M-1M05030			
SANYO DENKI CO., LTD.	SANMOTION R	R2□A04005	50	A1	D, K, S	
Panasonic Corporation	MINAS	A6 MSMF5A	50	K1	D, K, S	

Notes: 1. Contact THK if a motor other than the ones above will be mounted.

2. The table shows only a portion of the model numbers for motors. For details regarding model numbers, please see the catalog for each respective motor manufacturer.

## Selection Information

### Basic Specifications

Motor rated output (W)		50	
Ball screw	Screw shaft diameter (mm)	Ø8	
	Ball screw lead (mm)	6	
	Basic dynamic load rating Ca (N)	1,950	
	Basic static load rating C0a (N)	3,510	
	Thread minor diameter (mm)	Ø6.872	
	Ball center-to-center diameter (mm)	Ø8.4	
Bearing (fixed side)	Axial direction	Basic dynamic load rating Ca (N)	8,000
		Static permissible load P0a (N)	3,240
Positioning repeatability (mm)		±0.01	
Lost motion (mm)		0.1	
Rod non-rotating accuracy (°)		±1	
Starting torque* (N-cm)		1.6	
Max. input torque (N-m)		0.48	
Standard grease		THK AFB-LF Grease	

\* Timing pulley and timing belt are not included.

Note 3: Prepare a separate guide mechanism if a load will be applied to the rod in a non-axial direction.

### Wrapping Direction Details

Motor rated output (W)		50
Timing belt	Manufacturer	Gates Unitta Asia Company
	Model	196-2GT-6

### Maintenance

Standard grease: AFB-LF

For greasing of the ball screw, remove the plug and apply grease directly to the ball screw shaft.

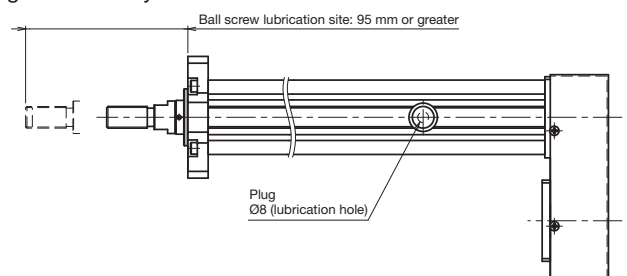

# Dimensions

## Direct Coupling

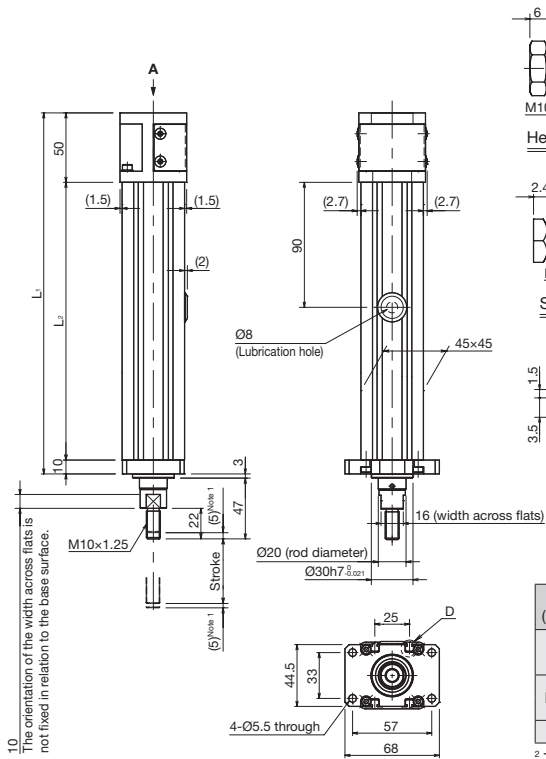

<sup>1</sup> This is the stroke up to the mechanical stopper.

## Motor Attachment Details

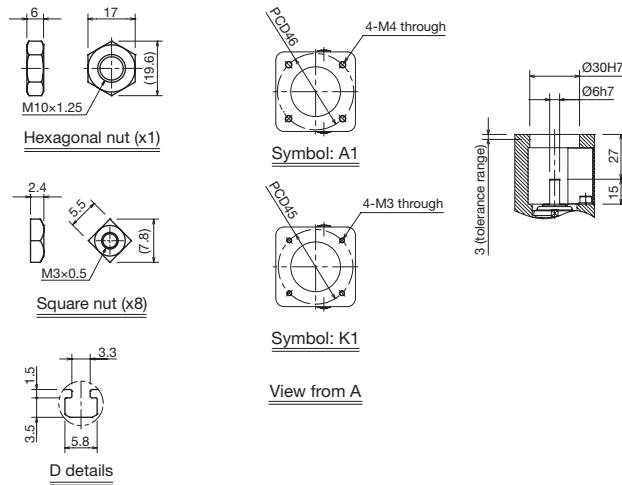

Stroke (mm) (Stroke between mechanical stoppers)	50 (60)	100 (110)	150 (160)	200 (210)
Maximum speed <sup>2</sup> (mm/s)	Ball screw lead: 6 mm			300
Dimensions (mm)	L <sub>1</sub>	260	310	360
	L <sub>2</sub>	200	250	300
Mass (kg)	1.4	1.6	1.8	2.1

<sup>2</sup> The maximum speed is restricted either by the rotational speed of the motor at 3,000 min<sup>-1</sup> or by the permissible speed of the actuator.

## Motor Wrap

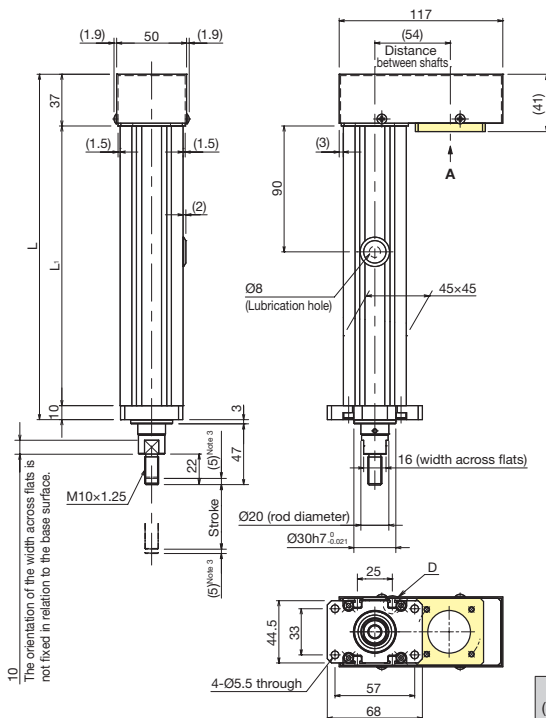

<sup>3</sup> This is the stroke up to the mechanical stopper.

## Motor Attachment Details

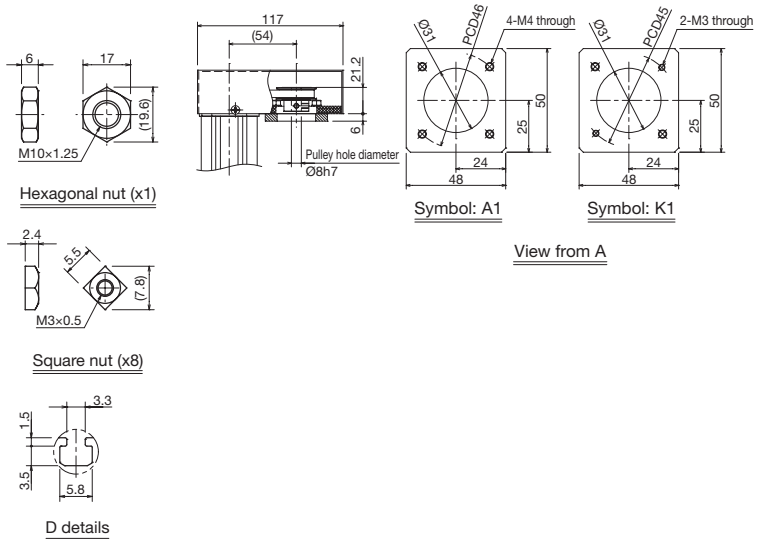

Stroke (mm) (Stroke between mechanical stoppers)	50 (60)	100 (110)	150 (160)	200 (210)
Maximum speed <sup>4</sup> (mm/s)	Ball screw lead: 6 mm			300
Dimensions (mm)	L	247	297	347
	L <sub>1</sub>	200	250	300
Mass (kg)	1.6	1.8	2	2.2

<sup>4</sup> The maximum speed is restricted either by the rotational speed of the motor at 3,000 min<sup>-1</sup> or by the permissible speed of the actuator.

# PCT25/PCT25R



## Model Number Coding

Model ①	Lead, reduction ratio ②	Stroke ③	Options ④	With/without motor ⑤	Motor bracket ⑥	Motor shaft securing method ⑦
PCT25R	04N	0200	R	0	A1	D
<b>PCT25</b>	<b>04N</b>	<b>0050: 50 mm</b>	<b>With direct coupling</b>	<b>0: Without motor</b>	<b>A1</b>	<b>With direct coupling</b>
<b>PCT25R</b>	<b>06N</b>	<b>to</b>	<b>N: Direct coupling</b>	Direct motor coupling specification: No coupling will be included. Please specify if a coupling is required when ordering. Motor wrap specification: Timing pulley and timing belt will be included.	<b>A2</b>	<b>No symbol</b>
		<b>0300: 300 mm</b>	<b>With motor wrap</b>		<b>K1</b>	<b>With motor wrap</b>
			<b>D: Bottom</b>		<b>K2</b>	<b>D: Flat</b>
			<b>L: Left</b>		<b>B1</b>	<b>K: Key</b>
			<b>R: Right</b>		<b>B2</b>	<b>S: Clamp</b>

\*R\* indicates motor wrap.

### ④ Option (Motor Wrap)

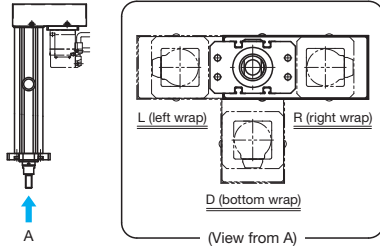

When "PCT25R" is selected for ① Model, "N" cannot be selected.

## Motor Bracket and Motor Shaft Securing Method Compatibility

### Direct Coupling

Motor type	Manufacturer	Series	Motor model	Motor rated output (W)	Motor bracket	Compatible coupling	
AC servo motor	YASKAWA Electric Corporation	Σ-7	SGM7J-01	100	A1	SFC-020DA2-8B-8B (MIKI PULLEY CO., LTD.) XGT2-25C-8-8 Nabeya Bi-tech Kaisha (NBK)	
			SGM7A-01				
		Σ-X	SGMJ-01				
			SGMXA-01				
	Mitsubishi Electric Corporation	MELSERVO	J4 HG-KR13	100	A1		
			J5 HG-MR13				
	TAMAGAWA SEIKI CO., LTD.	TBL-III	TS4603	100	A1		
		TBL-IV	TSM3104				
	OMRON Corporation	OMNUC	G5 R88M-K10030	100	A1		
			1S R88M-1M10030				
	SANYO DENKI CO., LTD.	SANMOTION R	R2□A04010	100	A1		
	AC servo motor	YASKAWA Electric Corporation	Σ-7	SGM7J-02	200		A2
				SGM7A-02			
			Σ-X	SGMJ-02			
				SGMXA-02			
		Mitsubishi Electric Corporation	MELSERVO	J4 HG-KR23	200		A2
				J5 HG-MR23			
		TAMAGAWA SEIKI CO., LTD.	TBL-III	TS4607	200		A2
			TBL-IV	TSM3202			
SANYO DENKI CO., LTD.		SANMOTION R	R2□A06020	200	A2		
Panasonic Corporation		MINAS	A6 MSMF01	100	K1		
OMRON Corporation	OMNUC	G5 R88M-K20030	200	K2			
		1S R88M-1M20030					
Panasonic Corporation	MINAS	A6 MSMF02	200	K2			
Stepper motor	ORIENTAL MOTOR CO., LTD.	α Step	AZ6*, AR6*	B1	SFC-020DA2-8B-10B (MIKI PULLEY CO., LTD.) XGT2-25C-8-10 Nabeya Bi-tech Kaisha (NBK)		
			5-phase PKP (this excludes PKP569FM*)			B1	
			2-phase PKP/CVD			B2	

### Motor Wrap

Motor type	Manufacturer	Series	Motor model	Motor rated output (W)	Motor bracket	Motor shaft securing method
AC servo motor	YASKAWA Electric Corporation	Σ-7	SGM7J-01	100	A1	D, K, S
			SGM7A-01			
		Σ-X	SGMJ-02			
			SGMXA-01			
	Mitsubishi Electric Corporation	MELSERVO	J4 HG-KR13	100	A1	
			J5 HG-MR13			
	TAMAGAWA SEIKI CO., LTD.	TBL-III	TS4603	100	A1	
			TS4607			
	Panasonic Corporation	MINAS	A6 MSMF01	100	K1	
	OMRON Corporation	OMNUC	G5 R88M-K10030	100	A1	
			1S R88M-1M10030			
	SANYO DENKI CO., LTD.	SANMOTION R	R2□A04010	100	A1	
	Panasonic Corporation	MINAS	A6 MSMF02	200	K2	
	OMRON Corporation	OMNUC	G5 R88M-K20030	200	K2	
			1S R88M-1M20030			
	Panasonic Corporation	MINAS	A6 MSMF02	200	K2	

Notes: 1. Contact THK if a motor other than the ones above will be mounted.  
2. The table shows only a portion of the model numbers for motors. For details regarding model numbers, please see the catalog for each respective motor manufacturer.

## Selection Information

### Basic Specifications

Motor rated output (W)		100		200	
Ball screw	Screw shaft diameter (mm)	Ø14	Ø12	Ø14	Ø12
	Ball screw lead (mm)	4	6	4	6
	Basic dynamic load rating Ca (N)	6,600	4,910	6,600	4,910
	Basic static load rating Coa (N)	12,300	9,600	12,300	9,600
	Thread minor diameter (mm)	Ø11.5	Ø9.872	Ø11.5	Ø9.872
	Ball center-to-center diameter (mm)	Ø14.4	Ø12.65	Ø14.4	Ø12.65
Bearing (fixed side)	Axial direction	Basic dynamic load rating Ca (N)	13,800		
		Static permissible load Poa (N)	5,850		
Positioning repeatability (mm)		±0.01			
Lost motion (mm)		0.1			
Rod non-rotating accuracy (°)		±1			
Starting torque <sup>1</sup> (N-cm)		2.8	3.2	2.8	3.2
Max. input torque <sup>2</sup> (N-m)		1.91 (0.95)		1.91	
Standard grease		THK AFB-LF Grease			

<sup>1</sup> Timing pulley and timing belt are not included.

<sup>2</sup> Values in parentheses are for motor wrap specifications.

Note 3: Prepare a separate guide mechanism if a load will be applied to the rod in a non-axial direction.

### Wrapping Direction Details

Motor rated output (W)		100		200	
Timing belt	Manufacturer	Gates Unittta Asia Company			
	Model	273-3GT-6	273-3GT-9		

## Maintenance

Standard grease: AFB-LF

For greasing of the ball screw, remove the plug and apply grease directly to the ball screw shaft.

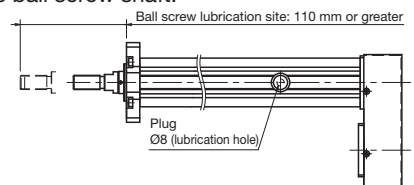

# Dimensions

## Direct Coupling

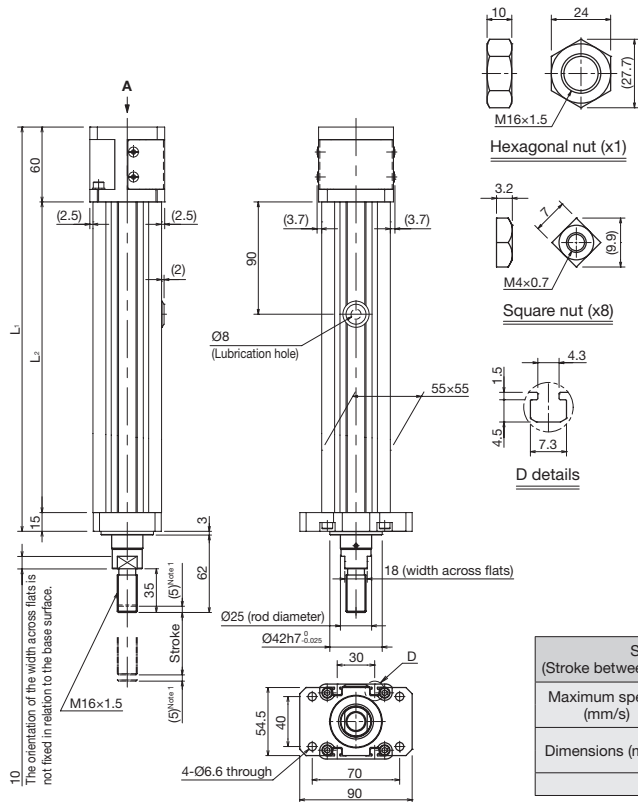

<sup>1</sup> This is the stroke up to the mechanical stopper.

## Motor Attachment Details

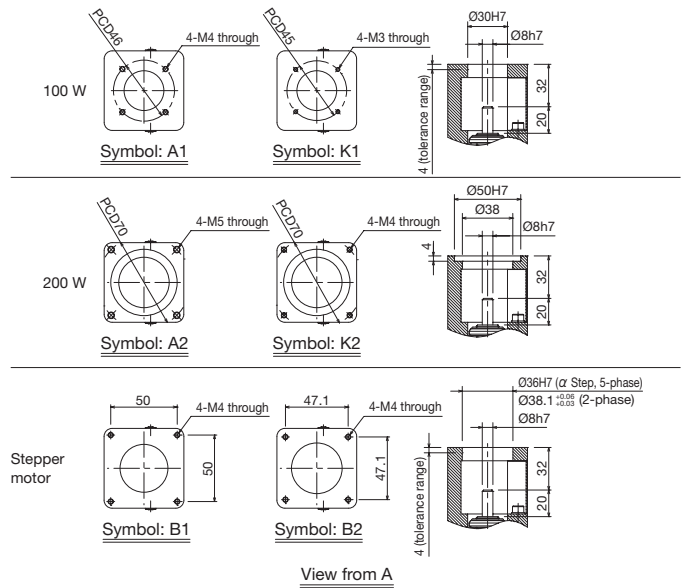

Stroke (mm) (Stroke between mechanical stoppers)	50 (60)	100 (110)	150 (160)	200 (210)	250 (260)	300 (310)
Maximum speed <sup>2</sup> (mm/s)	Ball screw lead: 4 mm		200		160	130
	Ball screw lead: 6 mm		300	260	200	160
Dimensions (mm)	L <sub>1</sub>	324	374	424	474	524
	L <sub>2</sub>	249	299	349	399	449
Mass (kg)	2.8	3.2	3.5	3.8	4.2	4.5

<sup>2</sup> The maximum speed is restricted either by the rotational speed of the motor at 3,000 min<sup>-1</sup> or by the permissible speed of the actuator.

## Motor Wrap

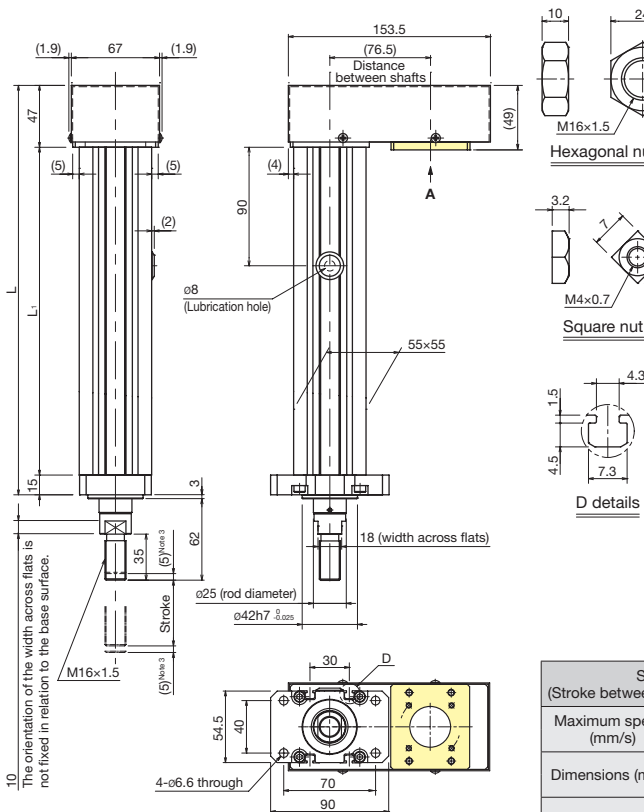

<sup>3</sup> This is the stroke up to the mechanical stopper.

## Motor Attachment Details

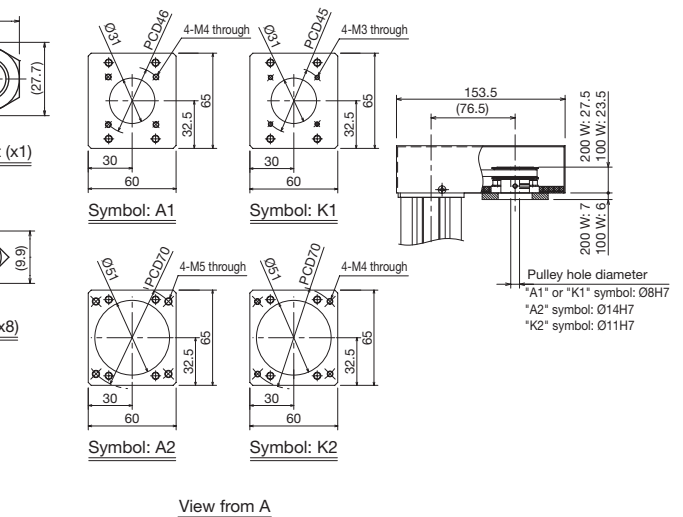

Stroke (mm) (Stroke between mechanical stoppers)	50 (60)	100 (110)	150 (160)	200 (210)	250 (260)	300 (310)
Maximum speed <sup>4</sup> (mm/s)	Ball screw lead: 4 mm		200		160	130
	Ball screw lead: 6 mm		300	260	200	160
Dimensions (mm)	L	311	361	411	461	511
	L <sub>1</sub>	249	299	349	399	449
Mass (kg)	3.1	3.4	3.8	4.1	4.4	4.7

<sup>4</sup> The maximum speed is restricted either by the rotational speed of the motor at 3,000 min<sup>-1</sup> or by the permissible speed of the actuator.



## Precautions on Use

### How to Use this Product

- This product must not be used for devices or systems that are utilized under situations that may affect human life.
- Be sure to contact THK in advance if you are considering using this product for special applications, such as with devices or systems relating to passenger vehicles, medicine, aerospace, nuclear power, or electric power.

### Products with Rotary Motor Drives

#### Handling

- Please contact THK when using the product in special environments such as locations exposed to constant vibrations, clean rooms, vacuums, and low/high temperatures.
- Tilting this product may cause it to fall by its own weight.

#### Safety Precautions

- Carefully read JIS B8433 “Manipulating Industrial Robots - Safety” and the Japanese Ministry of Health, Labour and Welfare’s “Ordinance on Industrial Safety and Health” before working with the product, and follow the guidance within.
- Carefully read the user manual, gain a sufficient understanding of its contents, and be sure to follow the safety precautions.
- When installing, adjusting, inspecting, or performing maintenance on the main actuator unit and connected peripherals, be sure to remove all power plugs from their outlets, and prepare a lock or safety plug to prevent anyone else from turning on the power. Additionally, place a sign in a visible location to notify others that work is being performed.
- Do not touch any moving parts of the actuator while it is energized. In addition, do not enter the operating range of this product while it is in operation or in an operable state.
- If performing a task involving multiple people, confirm how to perform the work, what signals will be used, and how to handle problems before beginning, and assign another person to monitor the work.
- Do not carelessly disassemble this product. Otherwise, it may cause foreign material ingress or decrease the accuracy.
- Take care not to drop or strike this product. Otherwise, it may cause injury or damage the unit. Even if there is no outward indication of damage, a sudden impact could prevent the unit from functioning properly.
- Using this product in excess of the permissible rotational speed may damage the components or cause an accident. Please use the product within the range of speeds we have specified.
- Prevent foreign materials such as cutting chips from entering the product. Otherwise, it may damage the ball circulation components or result in a loss of functionality.
- If using the product in an environment where coolant may get inside, contact THK.
- Install shock absorbers or another impact-absorbing mechanism if there is a risk that the slider may strike the stoppers mounted on both ends of the range of motion. The stoppers are not intended to absorb the impact from sliders. Impacts to the stoppers during operation may lead to damage or accidents.
- Using this product in excess of the torque limit may damage the components or cause an accident.
- Do not set the torque control parameter higher than the torque limit.
- The motor wrap type does not have a safety device for if the timing belt breaks. For your safety, please install a safety device next to the equipment.
- The PC is designed for pressing motions. Service life will deteriorate considerably if a load is applied in the pulling direction.
- The PCT can only bear loads in the axial direction. Use in conjunction with an LM Guide so that non-axial loads will not be applied to the rod.
- If rotational torque or a moment load will be applied to the PC rod, please contact THK.
- Some models of the PC are heavy, with the main unit weighing in excess of 20 kg. When moving these products, use a hoisting belt to lift them. Use appropriate transportation equipment and take safety precautions to avoid injury or damage when transporting or assembling the product. Do not lift this product by hooking only the hoisting belt to the main body of the unit. When moving the product in a vertical orientation for installation, use two belts: one on the motor side and one on the rod side. When moving the product in a horizontal orientation, use two or four belts on the motor side and rod side. Depending on the model, the main body may tilt when hoisted due to an unbalanced center of gravity. Take care not to cause an impact to the ball spline shaft when hoisting it.
- In applications where this product will be moved or transferred, the conditions of use may cause inertia from the motor’s mass to result in damage to the motor attachment (Housing A) or other parts. Please contact THK before using in this manner.

#### Operating Environment

- Indoors, with an ambient temperature between 0°C and 40°C and ambient humidity at 20 to 80% RH (no condensation)
- A location with no corrosive or flammable gas
- A location where vibrations or impacts are not transmitted to the main unit
- A location where electrically conductive particles such as steel dust, dust, oil mist, cutting oil, water content, salt content, or organic solvents will not be present in the air
- A location not exposed to direct sunlight or radiant heat
- A location where no strong electric fields or powerful magnetic fields are generated
- A location where inspections and cleanings can easily be performed
- If this product will be used in special environments, such as one with constant vibrations, in a vacuum, or at very low or high temperatures, contact THK.

#### Actuator Mounting Surface

- Prepare a flat surface that has been machined or possesses an equivalent level of accuracy. Some products specify a required level of flatness.
- Be sure to mount the product on a sufficiently rigid base.

#### Lubrication

- The actuator must be lubricated in order for it to demonstrate its full performance. Insufficient lubrication may increase wear on the rolling elements and lead to premature damage.
- Do not mix lubricants with different properties. Please be aware that the applied lubricant will differ depending on the product.
- Contact THK if a special lubricant will be used.
- Replenish the grease every 100 km traveled under normal circumstances or 500 km under normal operation with pressure applied at one end of the stroke, or once every 6 months, whichever comes sooner. However, this will vary depending on the usage conditions, so we recommend determining the greasing interval based on the initial inspection.
- Contact THK if the product will be used in a special environment such as a location with constant vibrations, a vacuum, high/low temperatures, or a clean room, as it may not be possible to use the regular lubricant.
- Contact THK if oil lubricant will be used.
- Thoroughly wipe off anti-rust oil and feed lubricant before using the product.
- Directly apply grease to the raceway of the screw shaft, as a grease nipple is not installed on the ball screw unit.

#### Storage

- When storing the actuator, enclose it in a package designated by THK and store it in a horizontal orientation while avoiding high temperatures, low temperatures, and high humidity.
- Avoid storing control devices in an environment with high/low temperatures or high humidity.

#### Disposal

- The product should be treated as industrial waste and disposed of appropriately.

## Other Recommended Products



### Caged Ball LM Guide Actuator SKR

- Modular structure reduces the number of parts, design hours, and assembly hours
- Caged ball effect enables a long service life and long-term maintenance-free operation
- Ideal for high-precision positioning and orthogonal, multi-axis designs



### LM Guide Actuator KR

- Modular structure reduces the number of parts, design hours, and assembly hours
- Can be used in various orientations, including horizontal, wall-mounted, vertical, and hanging
- Extensive lineup of 9 sizes

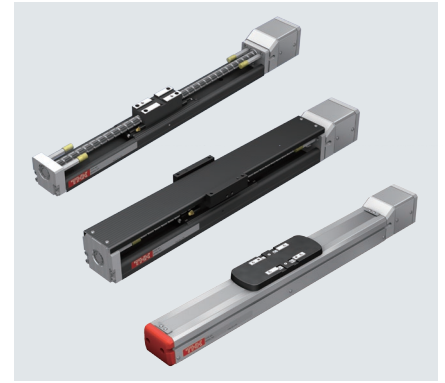

### LM Guide Actuator with Large-Diameter Ball Screw KSF

Open cover/top cover/fully enclosed

- Large-diameter ball screw enables high-speed and high-acceleration operations
- 3 types of cover options to choose from to suit the application
- Supports long strokes up to 1,500 mm

## Electric Cylinder PC/PCT

● **LM Guide and Caged Ball**  are registered trademarks of **THK CO., LTD.**

- The actual products may differ from the illustrations and photographs in this catalog.
- Outward appearances and specifications are subject to change without notice for the purpose of improvement. Please consult with THK before using.
- Although great care has been taken in the production of this catalog, THK will not take any responsibility for damages resulting from typographical errors or omissions.
- For exports of our products and technologies and sales for export, our basic policy is to comply with the Foreign Exchange and Foreign Trade Act and other laws and regulations. Please consult us in advance if you want to export our products by the piece.

All rights reserved.

# THK CO., LTD.

Global Headquarters 2-12-10 Shibaura, Minato-ku, Tokyo 108-8506 Japan  
International Sales Department Phone: +81-3-5730-3860  
[www.thk.com](http://www.thk.com)