



High-Speed Ball Screw with Ball Cage

Low noise

Long-term, maintenance free operation

Low torque fluctuation

DN value 130,000

SBN

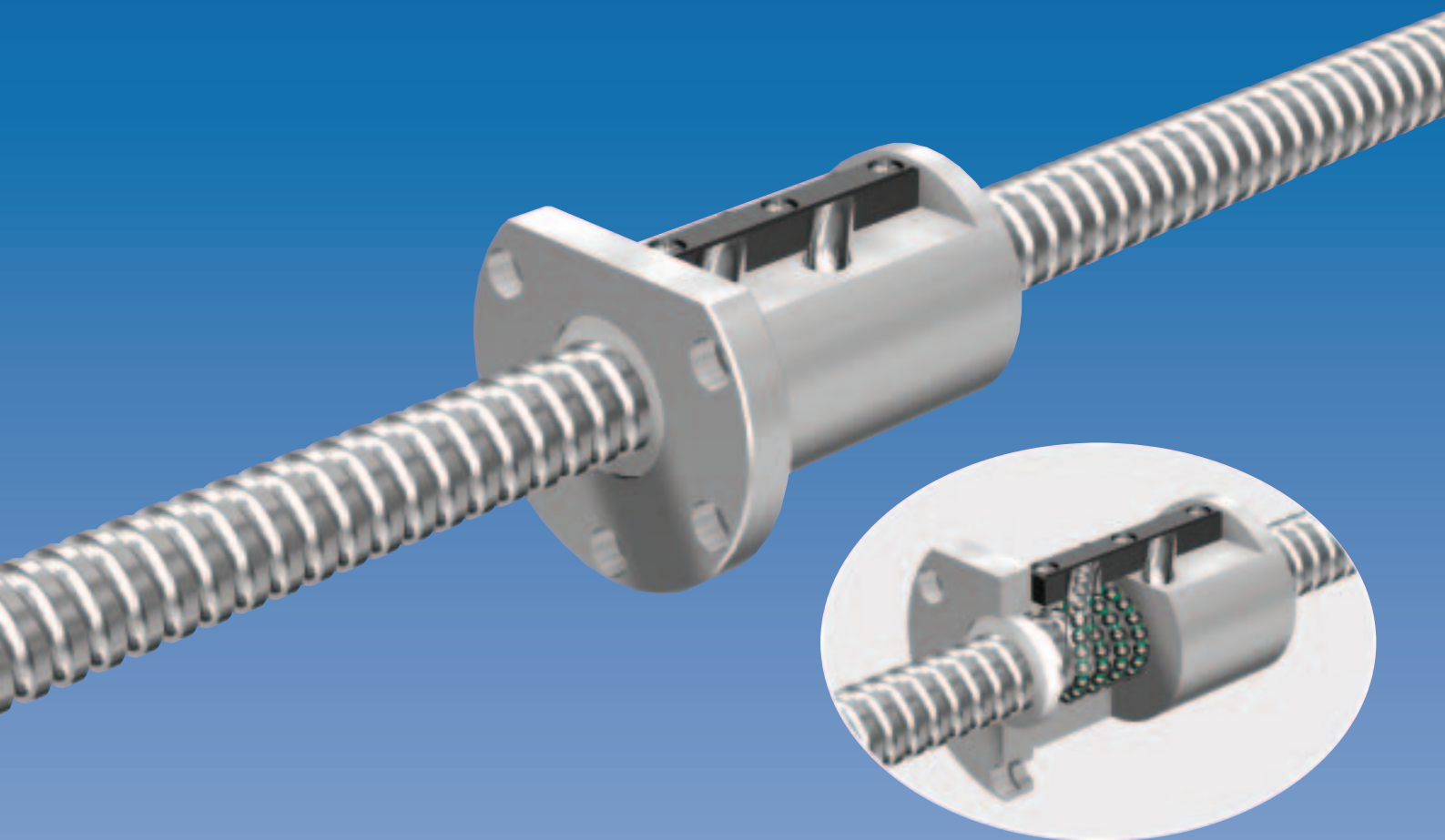



High speed ball screw with caged ball technology

SBN

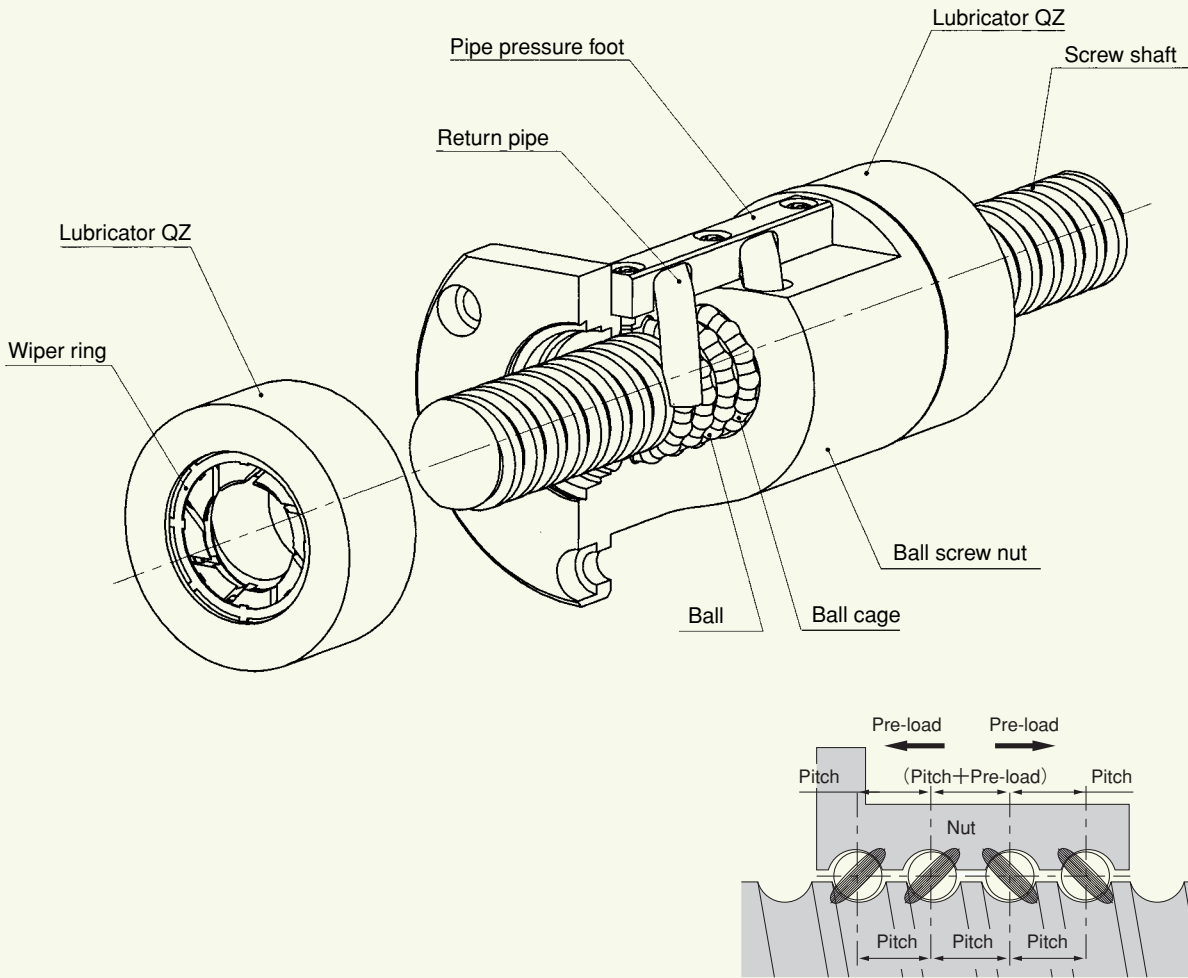

Fig.1 Structure of type SBN

Structure

A high-speed ball screw SBN is provided with caged ball technology in order to eliminate collisions and friction between balls and improve lubrication longevity. By doing this, low noise, excellent torque characteristics and long periods without maintenance were achieved.

Increasing the strength of the circulating part by making an ideal cycle which can pick up the ball at a direction tangential with the return pipe, permissible DN values of 130,000 were realized. (*: DN value = ball center diameter × number of rotations per minute)

Using an offset pre-load method that shifts the lead at the center of the nut allows for a shorter and more compact nut compared to the double nut used for the shim pre-load method.

With full use of the LM guide with Caged Ball™ technology developed as a result of our extensive experience and new manufacturing techniques, the ball screw with a ball cage, corresponding to high speed demands in the market, performs extremely well with regards to the following features.

Features

High speed correspondence

The SBN type return pipe is the ideal circulation method and does not have a lip so that the ball is picked up in a tangential direction and a flexible ball track can be held.

The design, with enough strength in the return pipe and the ball cage, makes the use with DN value 130,000 possible.

Type SBN

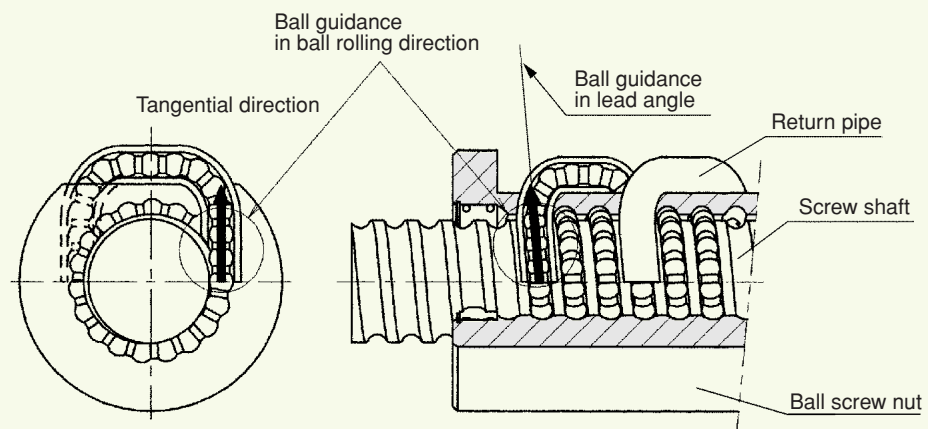

Conventional type

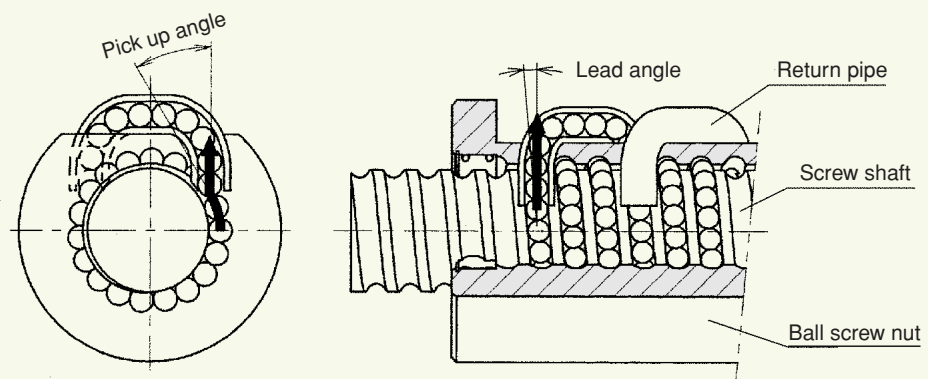

Low noise

The ball cage between balls eliminates collision noise.

The return pipe does not have a lip so that the ball is picked up at a tangential direction and collision noise is eliminated.

These devices result in low noise and high sound quality.

Long-term maintenance-free operation

The ball cage acts as a lubricant reservoir. Adding the optional wire ring and the lubricator QZ* makes long-term maintenance-free operation possible even in adverse environments (foreign matter or coolant).

(* : Please contact THK regarding the wiper ring and the lubricator QZ for ball screw.)

Excellent sliding

The ball cage eliminates ball to ball friction of balls and improves the torque characteristics greatly. A pre-load dynamic torque fluctuation is reduced and it is possible to achieve excellent sliding.

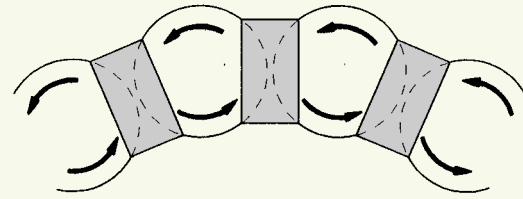

Caged ball technology

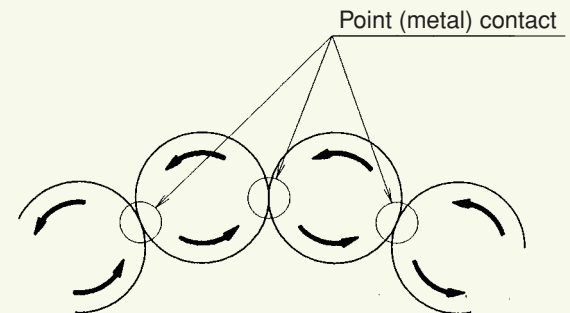

Conventional construction

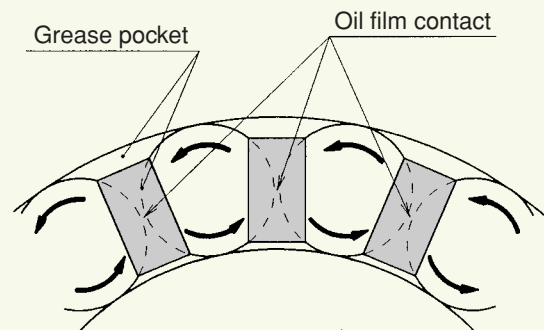

Grease pocket

■ High speed & load durability

Type SBN uses a new re-circulation tube and caged ball technology to achieve smooth circulation which maintains high speed and improved load durability.

High speed durability test

Test condition

Model Number	SBN3210-7
Rotational speed	3900 (min ⁻¹) (DN value : 130,000)
Stroke	400mm
Lubricant	AFG grease
Apply	12cm ³ (applied every 1000km)
Load	1.73kN
Acceleration	1G

Test result

No problems after 5000km travel

Load durability test

Test condition

Model Number	SBN3210-7
Rotational speed	1500 (min ⁻¹)
Stroke	300mm
Lubricant	AFG grease
Apply	12cm ³
Load	17.3kN
Acceleration	0.5G

Test result

Operated for 2.5 times estimated life span without a problem (Currently in operation)

■ Smooth rotation

Type SBN uses caged ball technology, so it is possible to get smoother rotation compared to conventional types.

Category	Data
Shaft diameter / lead	32 / 10 mm
Rotational speed	60min ⁻¹

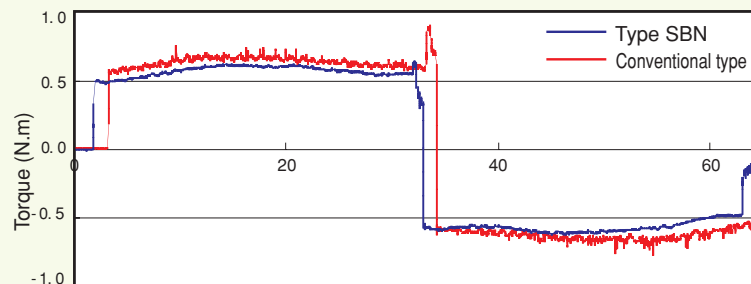

Torque data

■ Noise level data

Type SBN maintains quiet operation under high-speed rotation by adopting caged ball technology that eliminates collisions of adjacent metal balls.

Item	Description
Lubricator	THK AFG grease
Measure distance	As shown in graph below

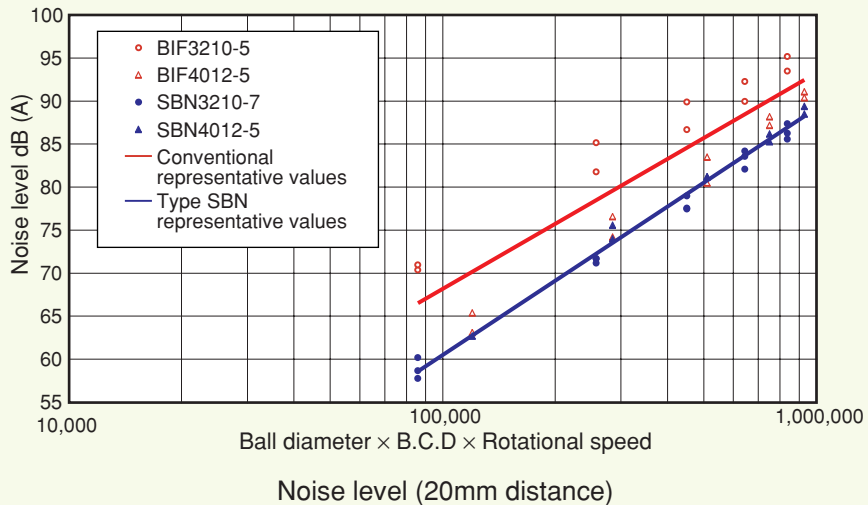
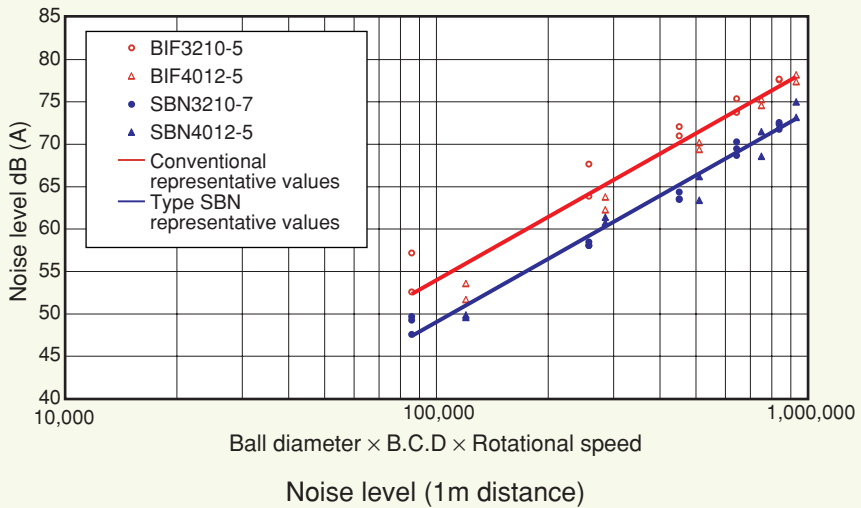
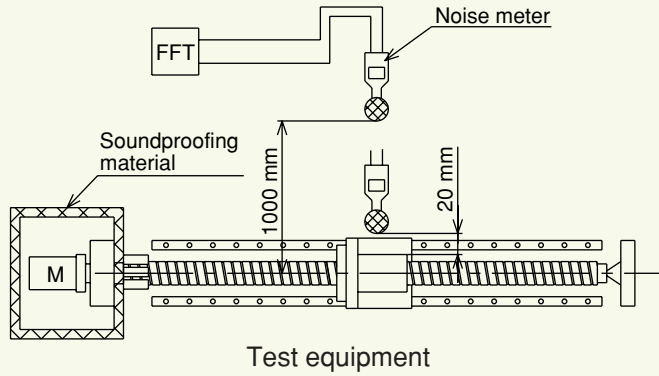

Accuracy standard

The THK high-speed ball screw with caged ball technology is manufactured to a level of accuracy compliant with the JIS B1192 standard (precision ball screws). It is manufactured to high-accuracy C0 grade. The reliability of lead accuracy measurement is guaranteed by the use of a laser measurement device. For details on standard values, refer to the general catalogue.

Load ratings and life

Basic load rating Ca

Basic load rating Ca is used to calculate the life span of a ball screw when the nut moves due to being subject to a load.

The Ca basic load rating is called the axial directional load when revolving each of a set of identical ball screws having a rated life span of 90% at 106 rev. (1,000,000 revolutions).

Life calculation

From the basic load rating and axial directional load, the life span of a ball screw is calculated using the following equation.

$$L = \left(\frac{Ca}{fw \cdot Fa} \right)^3 \times 10^6$$

L : Rated life span rev
 Ca : Basic load rating N
 Fa : Axial directional load N
 fw : Load factor (Table 1)

Basic static load rating Coa

If the ball screw is subject to an excessive load or large collision load when in a static or moving state, localized permanent deformation will occur between the raceway surface and steel balls. This will prevent smooth motion if the amount of permanent deformation exceeds a specific limit.

In general, operation is regarded to be no problem if the extent of permanent deformation is 0.0001 times the diameter of the steel balls, and the load at this level is called basic static load rating Coa. Consideration of a static stability factor such as in table 2 is required with regards to the axial directional load resulting from operating conditions.

Table 1 Load Factor (fw)

Vibration and collision	Velocity (v)	fw
Slight	At very low speed $V \leq 0.25$ m/s	1.0~1.2
Small	At low speed $0.25 < V \leq 1.0$ m/s	1.2~1.5
Medium	At medium speed $1.0 < V \leq 2.0$ m/s	1.5~2.0
Large	At high speed $V > 2.0$ m/s	2.0~3.5

The life span can be calculated as in the following equation, when you know the rotational life span L, and the stroke length and reciprocating frequency are fixed.

$$Lh = \frac{L \times R}{2 \times \ell_s \times n_1 \times 60}$$

Lh : Life in terms of time h
 ℓ_s : Stroke length mm
 n_1 : Number of reciprocating motions per minute min⁻¹
 R : Lead mm

Table 2 Static Stability Factor (Fs)

Applicable machine	Load condition	Lower limit of Fs
General-purpose industrial machine	When no vibration and collision When subject to vibration and collision	1.0~1.3 2.0~3.0
Machine tool	When no vibration and collision When subject to vibration and collision	1.0~1.5 2.5~7.0

$$f_s \leq \frac{Coa}{Fa}$$

f_s : Static stability factor (Table 2)
 Coa : Basic static load rating kN
 Fa : Axial directional load kN

Notes on use

Permissible rotational frequency

When the rotational frequency becomes high, the screw shaft nears natural frequency leading to resonating and in some cases resulting in movement failure. It is therefore necessary to consider using the ball screw below resonance point (critical speed). (For details, refer to the general catalogue.) Furthermore, the DN value is also limited regardless of the method of mounting. It is necessary to consider both of these points. (Permissible DN value of 130,000 for type SBN.)

Recommended grease

Using a ball screw at high rotational speeds generates a large amount of heat. AFG grease is recommended for operation at high speeds.

Type SBN

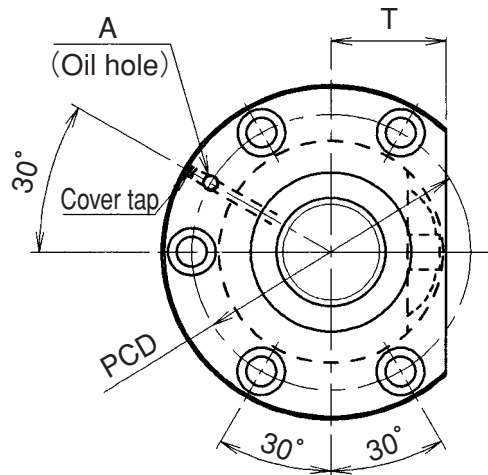

Model number	Screw shaft outer diameter d	Lead R	Load circuit number Row × winding	Ball center diameter dp	Screw shaft root diameter d ₃	Basic rated load		Rigidity K N/μm
						Ca kN	Coa kN	
SBN3210-7	32	10	1 × 3.5	33.75	26.4	43.0	73.1	836.7
SBN3212-5	32	12	1 × 2.5	34	26.1	37.4	58.7	612.2
SBN3610-7	36	10	1 × 3.5	37.75	30.4	45.6	82.3	920.9
SBN3612-7	36	12	1 × 3.5	38	30.1	53.2	92.6	934.5
SBN3616-5	36	16	1 × 2.5	38	30.1	39.7	66.4	676
SBN4012-5	40	12	1 × 2.5	42	34.1	42.0	73.6	735.4
SBN4016-5	40	16	1 × 2.5	42	34.1	41.9	73.8	736.6
SBN4512-5	45	12	1 × 2.5	47	39.2	44.4	82.9	809.1
SBN4516-5	45	16	1 × 2.5	47	39.2	44.3	83.1	810.1
SBN5012-5	50	12	1 × 2.5	52	44.1	46.6	92.2	880.9
SBN5016-5	50	16	1 × 2.5	52	44.1	46.6	92.4	881.7
SBN5020-5	50	20	1 × 2.5	52	44.1	46.5	92.6	882.8

Model Number Coding

SBN3210-7 QZ RR G0 + 1200L C5

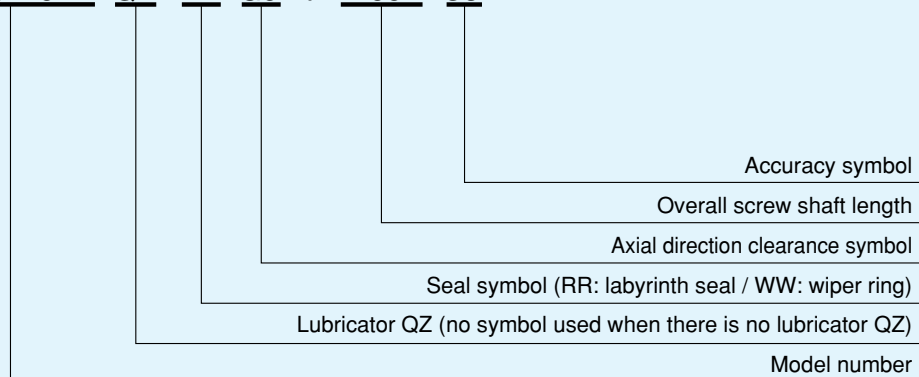

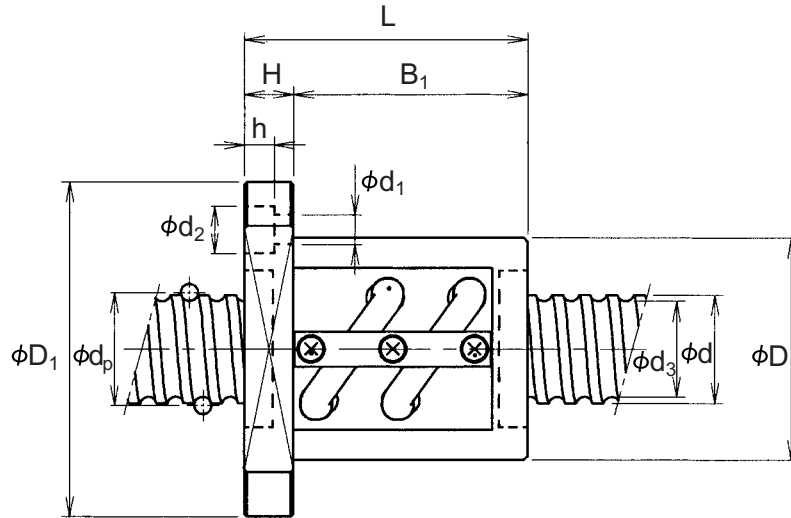

Unit: mm

Outer diameter D _{g6}	Flange diameter D1	Length L	Ball screw nut dimension					Oil hole A	Screw-shaft inertial moment/mm kg-cm ² /mm	Maximum permissible rotation min ⁻¹
			H	B1	PCD	d ₁ × d ₂ × h	V			
74	108	120	15	105	90	9 × 14 × 8.5	38	M6	8.08 × 10 ⁻³	3850
76	121	117	18	99	98	11 × 17.5 × 11	39	M6	8.08 × 10 ⁻³	3800
77	120	123	18	105	98	11 × 17.5 × 11	40	M6	1.29 × 10 ⁻²	3400
81	124	140	18	122	102	11 × 17.5 × 11	42	M6	1.29 × 10 ⁻²	3400
81	124	140	18	122	102	11 × 17.5 × 11	42	M6	1.29 × 10 ⁻²	3400
84	126	119	18	101	104	11 × 17.5 × 11	43	M6	1.97 × 10 ⁻²	3050
84	126	144	18	126	104	11 × 17.5 × 11	43	M6	1.97 × 10 ⁻²	3050
90	130	119	18	101	110	11 × 17.5 × 11	46	PT1/8	3.16 × 10 ⁻²	2750
90	130	140	18	122	110	11 × 17.5 × 11	46	PT1/8	3.16 × 10 ⁻²	2750
95	141	119	22	97	117	14 × 20 × 13	48	PT1/8	4.82 × 10 ⁻²	2500
95	141	143	22	121	117	14 × 20 × 13	48	PT1/8	4.82 × 10 ⁻²	2500
95	141	169	22	147	117	14 × 20 × 13	48	PT1/8	4.82 × 10 ⁻²	2500

Note: The rigidity values in the table represent spring constants each obtained from the load and the elastic displacement when providing a preload 10% of the basic dynamic load rating (Ca) and applying an axial load three times greater than the preload. These values do not include the rigidity of the components related to mounting the ball screw nut. Therefore, it is normally appropriate to regard roughly 80% of the value in the table as the actual value.

If the applied preload (Fa0) is not 0.1 Ca, the rigidity value (KN) is obtained from the following equation.

$$K_N = K \left(\frac{Fa_0}{0.1Ca} \right)^{\frac{1}{3}} \quad \kappa : \text{Rigidity value in the dimensional table.}$$

●Note

With model SBN, the screw shaft cannot be threaded at both ends. If designing SBN with threaded ends, contact .

Type SBN can be equipped with lubricator QZ, which is a ball screw lubricator system containing a high-density fiber net with high oil content for longer maintenance-free periods, as well as a contact seal and wiper ring offering superb contamination protection capabilities for ball screws.

■ Lubricator QZ

Lubricator QZ is a new lubricating system that can supply an appropriate amount of lubricating oil to the parts requiring it.

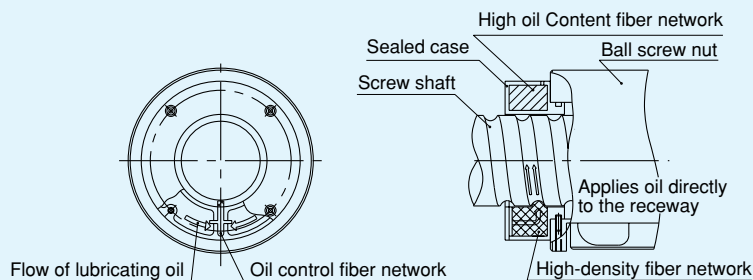

< Features >

• Enables longer maintenance-free intervals

Normally, a small amount of oil is lost from ball screws during operation. By adding the lubricator QZ, oil lost over long periods is automatically replaced, greatly lengthening maintenance-free intervals.

• Lubricator QZ is environmentally conscious

Because lubricator QZ uses a high-density fiber net to supply the appropriate amount of oil to the appropriate positions, there is no excess oil, making it an environmentally conscious design.

• The best oil for each application can be used

Lubricator QZ permits the use of the most suitable oil for the operating environment. For further details contact . (Applicable lubricating oil standard = ISO VG220)

■ Wiper Ring

The wiper ring adopts a specialized resin with friction resistant properties that forms an elastic contact on the outer shaft and screw grooves, thus protecting the slits in 8 places from contamination and preventing foreign matter from penetrating into the ball screw nut.

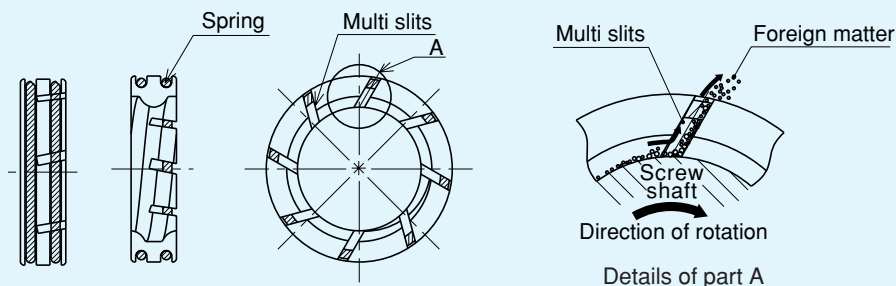

Structure of wiper ring

< Features >

- Prevents foreign matter penetrating the ball screw nut.
- Suppresses heat generation by fixed-pressure contact with screw shaft.
- Excellent resistance to friction, collision and chemicals.
- Incorporating lubricator QZ makes long-term maintenance-free operation a reality, even in adverse environments.

Note: The wiper ring cannot be fitted when processing the type SBN surface.

SBN with options

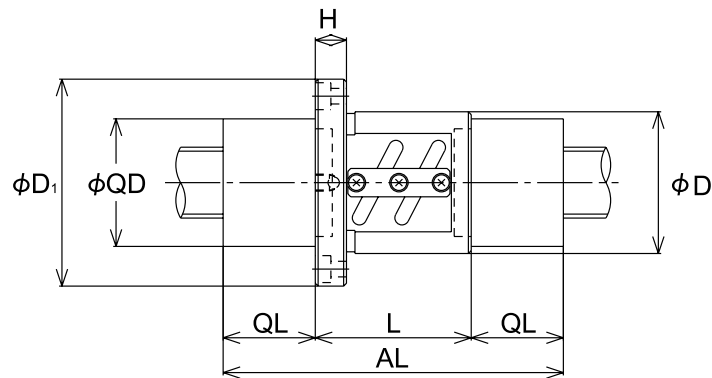

Model number	Ball screw nut dimensions				QZ dimensions		
	Nut length L	Flange width H	Flange diameter D ₁	Nut outer diameter D _{g6}	QZ Length QL	QZ outer diameter QD	QZ device total length AL
SBN3210-7	120	15	108	74	31	73	182
SBN3212-5	117	18	121	76	33	73	183
SBN3610-7	123	18	120	77	33	64	189
SBN3612-7	140	18	124	81	35	64	210
SBN3616-5	140	18	124	81	32	64	204
SBN4012-5	119	18	126	84	38	66	195
SBN4016-5	144	18	126	84	42	66	228
SBN4512-5	119	18	130	90	35.5	79	190
SBN4516-5	140	18	130	90	35.5	79	211
SBN5012-5	119	22	141	95	38.5	79	196
SBN5016-5	143	22	141	95	38.5	79	220
SBN5020-5	169	22	141	95	40.5	79	250

THK High speed ball screw with ball cage

SBN

Precautions on Use

● Handling

- Disassembling components may cause dust to enter the system or degrade mounting accuracy of parts. Do not disassemble the product.
- Tilting the screw shaft and the ball screw nut may cause them to fall by their self-weights.
- Dropping or hitting the Ball Screw may damage the ball circulation section, which may cause functional loss. Giving an impact to the product could also cause damage to its function even if the product looks intact.

● Lubrication

- Thoroughly remove anti-corrosion oil and feed lubricant before using the product.
- Do not mix lubricants of different physical properties.
- In locations exposed to constant vibrations or in special environments such as clean rooms, vacuum and low/high temperature, normal lubricants may not be used. Contact THK for details.
- When planning to use a special lubricant, contact THK before using it.
- Lubrication interval varies according to the service conditions. Contact THK for details.

● Precautions on Use

- Do not remove the ball screw nut from the screw shaft. Doing so may cause the balls or the ball cage to fall off.
- Entrance of foreign matter to the ball screw nut may cause damage to the ball circulating path or functional loss. Prevent foreign matter, such as dust or cutting chips, from entering the system.
- If foreign matter adheres to the product, replenish the lubricant after cleaning the product. For the type of cleaning liquid, contact THK.
- Use a cover or the like to prevent the coolant from entering the ball screw nut.
- Do not use the product at temperature of 80°C or higher. When desiring to use the system at temperature of 80°C or higher, contact THK in advance.
- If using the product with vertical mount, the ball screw nut may fall by its self-weight. Attach a mechanism to prevent it from falling.
- Using the product at speed exceeding the permissible rotation speed may cause breakage of a component or accident. Be sure to use the product within the specification range designated by THK.
- Forcibly driving in the screw shaft or the ball screw nut may cause an indentation on the raceway. Use care when mounting components.
- If an offset or skewing occurs with the ball screw shaft support and the ball screw nut, it may substantially shorten the service life. Pay much attention to components to be mounted and to the mounting accuracy.
- When using the product in locations exposed to constant vibrations or in special environments such as clean rooms, vacuum and low/high temperature, contact THK in advance.
- Letting the ball screw nut overrun will cause balls to fall off or the ball-circulating component to be damaged. Be sure not to let it overrun.

● Storage

When storing the Ball Screw, enclose it in a package designated by THK and store it in a horizontal orientation while avoiding high temperature, low temperature and high humidity.

● “LM Guide,” “Ball Cage,” “,” and “QZ” are registered trademarks of THK CO., LTD.

- The photo may differ slightly in appearance from the actual product.
 - The appearance and specifications of the product are subject to change without notice. Contact THK before placing an order.
 - Although great care has been taken in the production of this catalog, THK will not take any responsibility for damage resulting from typographical errors or omissions.
 - For the export of our products or technologies and for the sale for exports, THK in principle complies with the foreign exchange law and the Foreign Exchange and Foreign Trade Control Law as well as other relevant laws.
- For export of THK products as single items, contact THK in advance.

All rights reserved

THK CO., LTD.

HEAD OFFICE 3-11-6, NISHI-GOTANDA, SHINAGAWA-KU, TOKYO 141-8503
JAPAN

NORTH AMERICA

CHICAGO
PHONE:(847)310-1111 FAX:(847)310-1182
NEW JERSEY
PHONE:(201)529-1950 FAX:(201)529-1962
ATLANTA
PHONE:(770)840-7990 FAX:(770)840-7897
LOS ANGELES
PHONE:(714)891-6752 FAX:(714)894-9315
SAN FRANCISCO
PHONE:(925)455-8948 FAX:(925)455-8965
BOSTON
PHONE:(781)575-1151 FAX:(781)575-9295
DETROIT
PHONE:(248)858-9330 FAX:(248)858-9455
TORONTO
PHONE:(905)712-2922 FAX:(905)712-2925
BRASIL (SÃO PAULO)
PHONE:(011)3767-0100 FAX:(011)3767-0101

EUROPE

DÜSSELDORF
PHONE:0049(0)2102-74250 FAX:0049(0)2102-7425-299
STUTTGART
PHONE:0049(0)7150-91990 FAX:0049(0)7150-9199-888
MÜNCHEN
PHONE:0049(0)89-3706160 FAX:0049(0)89-370616-26
U.K.
PHONE:0044(0)1908-303050 FAX:0044(0)1908-303070
MILANO
PHONE:0039-039-2842079 FAX:0039-039-2842527
BOLOGNA
PHONE:0039-051-6412211 FAX:0039-051-6412230
SWEDEN
PHONE:0046(0)8-4457630 FAX:0046(0)8-4457639
AUSTRIA
PHONE:0043(0)7229-51400 FAX:0043(0)7229-51400-79
SPAIN
PHONE:0034-93-652-5740 FAX:0034-93-652-5746
THK FRANCE S. A. S.
PHONE:0033(0)4-37491400 FAX:0033(0)4-37491401
SOUTH AFRICA
PHONE:0027(0)44-2720020 FAX:0027(0)44-2720020

CHINA

THK SHANGHAI CO.,LTD.
PHONE:(21)6334-5131 FAX:(21)6334-5137
BEIJING
PHONE:(10)6590-3259 FAX:(10)6590-3557
THK SHOZHAN CO.,LTD.
PHONE:2376-1091 FAX:2376-0749
TAIWAN
TAIPEI
PHONE:(02)2888-3818 FAX:(02)2888-3819
TAICHUNG
PHONE:(04)2359-1505 FAX:(04)2359-1506
SOUTHERN
PHONE:(06)289-7668 FAX:(06)289-7669
KOREA (SEOUL)
PHONE:(02)3468-4351 FAX:(02)3468-4353
MALAYSIA (KUALA LUMPUR)
PHONE:(03)9287-1137 FAX:(03)9287-8071
INDIA (BANGALORE)
PHONE:(080)2330-1524 FAX:(080)2330-1524

